

**CADDO PARISH COMMISSION**  
**505 TRAVIS STREET, GOVERNMENT PLAZA**  
**PUBLIC NOTICE**  
**REGULAR MEETING AGENDA**  
Streaming at [www.caddo.org](http://www.caddo.org)  
February 17, 2022  
**3:30 P.M.**

1. ROLL CALL:

**Commissioners:**

Hopkins	District 1	Gage-Watts	District 7
Johnson	District 2	Taliaferro	District 8
Jackson	District 3	Atkins	District 9
Young	District 4	Chavez	District 10
Burrell	District 5	Lazarus	District 11
Jones	District 6	Epperson	District 12

2. INVOCATION:

3. PLEDGE OF ALLEGIANCE:

Veterans and active military members saluting during recitation of the Pledge of Allegiance would be appropriate, should you wish to do so.

4. AGENDA ADDITIONS:

- 4.I. Potential Agenda Addition: Special Resolution For Dr. Russell Ledet (Chavez)

Documents:

[SR FOR RUSSELL LEDET.PDF](#)

5. CITIZENS COMMENTS:

Citizens who wish to address the Commission on any issue other than zoning, please fill out a comment card located in the chamber foyer and return to the President or the Clerk of the

Commission. Individual comments are limited to 3 minutes

NOTE: Citizens who wish to address the Commission on matters relative to public hearings (items listed on the agenda only) will be limited to a cumulative total of 15 minutes each, for or against an issue. Those who wish to speak or make a presentation are asked to select their speakers and address the points they wish considered with this limitation in mind.

6. VISITORS:

7. ADOPT REGULAR SESSION MINUTES:

7.I. Regular Session Minutes February 3, 2022

Documents:

[2.3.2022 REGULAR SESSION MINUTES.PDF](#)

8. SPECIAL RESOLUTIONS:

8.I. Special Resolution Of Recognition & Appreciation For Christopher Thomas, Jr.  
(Chavez)

Documents:

[SR FOR CHRISTOPHER THOMAS JR..PDF](#)

8.II. Special Resolution Of Remembrance For Bobbie Cates Hicks  
(Atkins)

9. COMMUNIQUES AND COMMITTEE REPORTS:

**Administration response to information requests from Commissioners**

9.I. Administration Report

Documents:

[ADMINISTRATION REPORT 02.14.22.PDF](#)

10. PRESIDENT'S REPORT:

11. PUBLIC HEARING ON ZONING ORDINANCES & CASES:

12. PUBLIC HEARING ON ORDINANCES:

12.I. Public Hearing For Ordinance No. 6191 Of 2022

AN ORDINANCE AMENDING THE BUDGET OF ESTIMATED REVENUES AND EXPENDITURES FOR THE RIVERBOAT FUND AND OIL AND GAS FUND IN THE AMOUNT OF \$10,000 TO PROVIDE AN APPROPRIATION FOR THE LOUISIANA ADVOCATES FOR IMMIGRANTS IN DETENTION ASSOCIATED WITH THE HIGHLAND CENTER AND TO OTHERWISE PROVIDE WITH RESPECT THERETO

(Young)

Documents:

[ORD NO. 6191- LA AID HIGHLAND.PDF](#)  
[ORD NO. 6191 FACT SHEET - LA AID HIGHLAND.PDF](#)  
[ORD NO. 6191 EXHIBIT- NGO APPLICATION FOR LA-AID.PDF](#)  
[ORD NO. 6191 EXHIBIT- APPLICATION COPY NOT SIGNED.PDF](#)

12.II. Public Hearing For Ordinance No. 6193 Of 2022

AN ORDINANCE CREATING THE I-49 NORTH CORRIDOR ECONOMIC DEVELOPMENT DISTRICT, STATE OF LOUISIANA;" DEFINING THE BOUNDARIES THEREOF FROM WHICH AREA LOCAL SALES TAX, PROPERTY TAX AND HOTEL OCCUPANCY TAX INCREMENTS WILL BE DETERMINED AND USED TO FINANCE ECONOMIC DEVELOPMENT PROJECTS IN ACCORDANCE WITH AND AS AUTHORIZED BY PART II OF CHAPTER 27 OF TITLE 33 OF THE LOUISIANA REVISED STATUTES OF 1950, AS AMENDED; AND PROVIDING FOR OTHER MATTERS IN CONNECTION WITH THE FOREGOING.

(Hopkins)

Documents:

[ORDINANCE NO. 6193 I-49 TIF DISTRICT 2021-REVISED.PDF](#)  
[ORDINANCE NO. 6193 FACT SHEET RE CREATION OF I-49 TIF-REVISED \(ORDINANCE\).PDF](#)

13. ZONING ORDINANCES (For Final Passage):

14. ORDINANCES (For Final Passage):

14.I. Ordinance No. 6191 Of 2022

AN ORDINANCE AMENDING THE BUDGET OF ESTIMATED REVENUES AND EXPENDITURES FOR THE RIVERBOAT FUND AND OIL AND GAS FUND IN THE AMOUNT OF \$10,000 TO PROVIDE AN APPROPRIATION FOR THE LOUISIANA ADVOCATES FOR IMMIGRANTS IN DETENTION ASSOCIATED WITH THE HIGHLAND CENTER AND TO OTHERWISE PROVIDE WITH RESPECT THERETO

(Young)

Documents:

[ORD NO. 6191- LA AID HIGHLAND.PDF](#)  
[ORD NO. 6191 FACT SHEET - LA AID HIGHLAND.PDF](#)  
[ORD NO. 6191 EXHIBIT- NGO APPLICATION FOR LA-AID.PDF](#)  
[ORD NO. 6191 EXHIBIT- APPLICATION COPY NOT SIGNED.PDF](#)

14.II. Ordinance No. 6193 Of 2022

AN ORDINANCE CREATING THE I-49 NORTH CORRIDOR ECONOMIC

DEVELOPMENT DISTRICT, STATE OF LOUISIANA;" DEFINING THE BOUNDARIES THEREOF FROM WHICH AREA LOCAL SALES TAX, PROPERTY TAX AND HOTEL OCCUPANCY TAX INCREMENTS WILL BE DETERMINED AND USED TO FINANCE ECONOMIC DEVELOPMENT PROJECTS IN ACCORDANCE WITH AND AS AUTHORIZED BY PART II OF CHAPTER 27 OF TITLE 33 OF THE LOUISIANA REVISED STATUTES OF 1950, AS AMENDED; AND PROVIDING FOR OTHER MATTERS IN CONNECTION WITH THE FOREGOING.

(Hopkins)

Documents:

[ORDINANCE NO. 6193 I-49 TIF DISTRICT 2021-REVISED.PDF](#)  
[ORDINANCE NO. 6193 FACT SHEET RE CREATION OF I-49 TIF-REVISED \(ORDINANCE\).PDF](#)

15. ZONING ORDINANCES (For Introduction By Title):

16. ORDINANCES (For Introduction By Title):

16.I. Introduce Ordinance No. 6194 Of 2022

AN ORDINANCE TO ACCEPT THE STREETS IN OLD TOWNE SUBDIVISION UNIT 1 INTO THE PARISH OF CADDO ROAD SYSTEM, AND TO OTHERWISE PROVIDE WITH RESPECT THERETO

(District 1)

Documents:

[ORD NO 6194 OLD TOWNE SUBDIVISION UNIT 1 STREETS ACCEPT ORD.DOC](#)  
[ORD NO 6194 FACT SHEET FOR OLD TOWNE SUBDIVISION UNIT 1 ORDINANCE \(1\).DOC](#)  
[ORD NO 6194- EXHIBIT A OLD TOWNE UNIT 1.PDF](#)

16.II. Introduce Ordinance No. 6195 Of 2022

AN ORDINANCE TO ACCEPT THE STREETS IN BLANCHARD LAKE ESTATES UNIT 4 INTO THE PARISH OF CADDO ROAD SYSTEM, AND TO OTHERWISE PROVIDE WITH RESPECT THERETO

(District 1)

Documents:

[ORD NO 6195 - BLANCHARD LAKE ESTATES UNIT 4 STREETS ACCEPT ORD \(1\).PDF](#)  
[ORD NO 6195 FACT SHEET FOR BLANCHARD LAKE ESTATES UNIT 4 ORDINANCE.PDF](#)  
[ORD NO 6195- EXHIBIT A BLANCHARD LAKE ESTATE UNIT 4 \(1\).PDF](#)

16.III. Introduce Of Ordinance No. 6196 Of 2022

AN ORDINANCE AMENDING THE BUDGET OF ESTIMATED REVENUES FOR THE AMERICAN RESCUE PLAN FUND TO PROVIDE AN APPROPRIATION FOR JUVENILE CENTER IN CADDO PARISH AND TO OTHERWISE PROVIDE WITH RESPECT THERETO

(Appropriations Committee)

Documents:

[ORD NO 6196- JUVENILE CENTER.PDF](#)  
[ORD NO 6196 FACT SHEET - JUVENILE ONE STOP CENTER.PDF](#)

16.IV. Introduce Ordinance No. 6197 Of 2022

AN ORDINANCE AMENDING THE BUDGET OF ESTIMATED REVENUES AND EXPENDITURES FOR THE RIVERBOAT FUND TO APPROPRIATE FUNDS FOR THE CADDO PARKS GRAB AND GO FEEDING PROGRAM AND TO OTHERWISE PROVIDE WITH RESPECT THERETO

(Appropriations Committee)

Documents:

[ORD NO 6197- GRAB AND GO FEEDING PROGRAM.PDF](#)  
[ORD NO 6197 GRAB AND GO FACT SHEET.PDF](#)  
[ORD NO 6197 GRAB AND GO EXHIBIT 1.PDF](#)

16.V. Introduce Ordinance No. 6198 Of 2022

AN ORDINANCE AMENDING THE BUDGET OF ESTIMATED REVENUES AND EXPENDITURES FOR THE RIVERBOAT FUND FOR THE YEAR 2022 TO PROVIDE AN ADDITIONAL APPROPRIATION OF \$15,000 FOR ROBINSON'S RESCUE AND TO OTHERWISE PROVIDE WITH RESPECT THERETO

(Appropriations, Animal Services)

Documents:

[ORD NO 6198 ROBINSONS RESCUE.PDF](#)  
[ORD NO 6198 FACT SHEET - ROBINSON RESCUE.PDF](#)

16.VI. Introduce Ordinance No. 6199 Of 2022

AN ORDINANCE AMENDING THE BUDGET OF ESTIMATED REVENUES AND EXPENDITURES FOR THE RIVERBOAT FUND FOR THE YEAR 2022 TO PROVIDE AN APPROPRIATION TO PROVIDE BALLISTIC VESTS FOR SHREVEPORT AND CADDO PARISH FIRE DISTRICTS, AND TO OTHERWISE PROVIDE WITH RESPECT THERETO

(Taliaferro)

Documents:

[ORD NO 6199 FIRE DISTRICT BALLISTIC VEST.PDF](#)  
[ORD NO 6199 FACT SHEET - FIRE BALLISTIC VEST.PDF](#)

16.VII. Introduce Ordinance No. 6200 Of 2022

AN ORDINANCE TO ESTABLISH A TEMPORARY PARISH PLANNING AND ZONING COMMISSION, TO PROVIDE FOR ITS MEMBERSHIP, TO PROVIDE FOR AN EFFECTIVE DATE, AND TO OTHERWISE PROVIDE WITH RESPECT THERETO

(Johnson and Chavez)

Documents:

[ORD NO. 6200- TEMPORARY PLANNING AND ZONING COMMISSION-  
JOHNSON AND CHAVEZ-CORRECTED.PDF](#)  
[ORD 6200 FACT SHEET FOR TEMPORARY PLANNING COMMISSION.PDF](#)

16.VIII. Introduce Ordinance No. 6202 Of 2022

AN ORDINANCE TO AUTHORIZE THE ADMINISTRATOR TO EXECUTE AN  
PREDIAL SERVITUDE OF PASSAGE AND RIGHT TO USE OVER PARISH  
PROPERTY LOCATED IN SOUTHWESTERN QUARTER OF SECTION 28,  
TOWNSHIP 22 NORTH RANGE 16 WEST AND TO OTHERWISE PROVIDE WITH  
RESPECT THERETO

(Public Works, Legal) (District 1)

Documents:

[ORD NO 6202- PREDIAL SERVITUDE.DOCX](#)  
[FACT SHEET FOR ORD NO 6202 - BLAKEMAN RIGHT OF PASSAGE.PDF](#)  
[ORD NO. 6202- EXHIBIT A.PDF](#)

16.IX. Introduce Ordinance No. 6203 Of 2022

AN ORDINANCE TO AUTHORIZE THE ADMINISTRATOR TO EXECUTE AN  
EASEMENT AND RIGHT-OF-WAY AGREEMENT WITH CADDEAUX GATHERING,  
LLC REGARDING A PIPELINE THROUGH AND UNDER PARISH PROPERTY  
LOCATED IN SECTION 7, TOWNSHIP 18 NORTH, RANGE 15 WEST, CADDO  
PARISH, LOUISIANA, AND TO OTHERWISE PROVIDE WITH RESPECT THERETO

(Public Works, Legal) (District 1)

Documents:

[ORDINANCE 6203- CADDEAUX.PDF](#)  
[FACT SHEET FOR ORD NO 6203 CADDEAUX GATHERING.PDF](#)  
[ORDINANCE 6203 EXHIBIT A.PDF](#)

17. WORK SESSION MINUTES:

17.I. Work Session Minutes February 14, 2022

Documents:

[2.14.2022 WORK SESSION MINUTES.PDF](#)

17.II. Work Session Minutes January 18, 2022

Documents:

[1.18.2022 WORK SESSION MINUTES.PDF](#)

18. RESOLUTIONS:

18.I. Resolution No. 20 Of 2022

A RESOLUTION CONFIRMING PARTICIPATION IN THE LOUISIANA COMMUNITY

DEVELOPMENT BLOCK GRANT FISCAL YEAR 2022 PUBLIC FACILITY  
IMPROVEMENT PROJECT WITH WATERWORKS DISTRICT NO. 7, IDENTIFYING  
PARTNERS AND OTHERWISE PROVIDING WITH RESPECT THERETO

(Finance)

Documents:

[RES NO 20 OF 2022- LADBG WATERWORKS NO 7 A ND E.PDF](#)

19. OLD BUSINESS:

20. NEW BUSINESS:

20.I. Appoint Mayor James Sims To The Caddo Parish Broadband Committee  
Hon. James Sims (Hopkins)

21. COMMUNIQUES AND REPORTS:

22. ADJOURN:

To all persons desiring to attend and observe a meeting of the Caddo Parish Commission, or who wish to present information to the body: If you have physical limitations that require special accommodations in order for you to attend and participate in a meeting of the Caddo Parish Commission, please contact the office of the Caddo Parish Commission Clerk at (318) 226-6596, at least 24 hours in advance of the meeting so that an effort can be made to provide those accommodations.

# State of Louisiana



## Parish of Caddo In the Name and By the Authority of The Caddo Parish Commission

### SPECIAL PROCLAMATION for DR. RUSSELL LEDET

**WHEREAS**, the Caddo Parish Commission is always pleased to recognize and honor those who seek to engaged and elevate the sons and daughters of Caddo Parish by sharing knowledge and perspectives that help to inspire and encourage them to reach manifest the excellence inside of them; and

**WHEREAS**, DR. RUSSELL LEDET is such a person whose message of inclusion and resilience has been created through his remarkable life and engaging public speaking style and will be Louisiana State University Shreveport's Office of Diversity, Inclusion and Community Engagement's featured Black History Month speaker; and

**WHEREAS**, Ledet is a native of Lake Charles, LA who was reared by a single mother and went on to proudly serve in the US Navy from 2004-2013 as a cryptologic technician First Class Petty Officer serving on both active and reserve duty where his service exposed him to a larger world, one in which he found success and built upon it with experiences like studying chemistry flash cards while working as a security guard at Baton Rouge General, earning a PhD from NYU in 2018, Pursuing a joint MD/MBA at Tulane. His experience returning to the same hospital where he had worked as a security guard a decade earlier, this time as a PhD. pursuing a joint MD/MBA and noticing the persistent lack of minority inclusion in healthcare, but also taking pride in those actively working to correct the imbalance inspired him to organize a photograph of 15 Black medical students posing in front of the former slave quarters of a Louisiana plantation. The photo series, The 15 White Coats, went viral and inspired the creation of an organization of the same name, founded by Ledet and dedicated to inspiring minority youth to reach beyond societal expectations to reach higher and believe in themselves and to close the representation gap in healthcare; and

**WHEREAS**, the 2022 Black History Month theme is Black Health and Wellness, making Ledet's voice and message ideal to feature; his engaging delivery has been featured on national media outlets including CNN, MSNBC, People Magazine, NPR, Washington Post, The Steve Harvey Show, Good Morning America, and the Kelly Clarkson show and Louisiana State University Shreveport's Office of Diversity, Inclusion and Community Engagement is elated to host Dr. Ledet as he brings his message of empowerment and self-determination; and

**NOW, THEREFORE, BE IT RESOLVED**, by the Caddo Parish Commission, that it does hereby declare and recognize and proclaim February 23<sup>rd</sup>, 2022 to be:

#### 'DR. RUSSELL LEDET DAY'

in Caddo Parish, Louisiana, in recognition and admiration of his notable achievements in both his personal pursuit of knowledge as well as his talent for inspiring excellence in others, providing encouragement, promoting inclusion, celebrating diversity, embracing perseverance, and illustrating the importance of setting & reaching goals beyond what societal limitations may expect.

**ATTEST:**

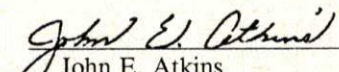

  
John E. Atkins  
President

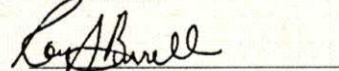
  
Roy Burrell  
Vice President

  
Mario Chavez  
District 10

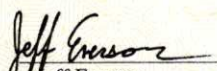
  
Jeff Everson  
Commission Clerk

MINUTES OF THE REGULAR SESSION OF  
THE CADDO PARISH COMMISSION  
HELD ON THE 3<sup>rd</sup> DAY OF FEBRUARY, 2022

The Caddo Parish Commission met in a Regular Session, on the above date, at 3:30 p.m., in the Government Chambers, with Mr. Atkins, presiding, and the following members in attendance constituting a quorum: Commissioners Atkins, Burrell, Chavez, Epperson, Gage-Watts, Hopkins, Jackson, Johnson, Jones, Lazarus, Taliaferro, and Young (12). ABSENT: None (0).

The invocation was given by Mr. Chavez, and Mr. Jones led the Commission in the Pledge of Allegiance.

**CITIZENS COMMENTS**

John Robinson came before the Commission and gave the following comment:

First of all, I would like to thank the Parish Commission for this opportunity to stand and address the issues that are affecting 53 homeowners who reside within 83 feet of HARASU 133, section 35, 17 North 16 West of the Greenwood Waskom field. At-It's located at Shirley Francis and Highway 169. This particular well is located at the south west corner of 169 and Shirley Francis. Now, we are you, no, your neighbors to the south or to the west. We're kissing cousins and we're known for several things and some of which you have heard of. Our hospitality being, far out of the City and our best reputation for being a speed trap. Now, if you were travelling through Greenwood going 75 miles an hour in a 35, chances are we trapped you, clocked you and gave you a citation. Or on the 120 at speeds in excess of 120 miles an hour, we sincerely hope that our Greenwood Police Department trapped you and gave you a citation as well. We were once known as a small quiet town, but that's no longer the case. We are now trapped by noise from oil and gas company's night and day; but according to them they can't stop. It's either our way or the highway as far as the noises is concerned that's affecting these 43 residents within 83 feet of their location. Just to touch on resolution one, where the thousand fifteen hundred feet is being considered. They feel that it's too restrictive. They need to be closer and I can tell you right now closer only causes ore noise with no abatement, 24/7. They never volunteered to erect the sound barrier and they've been told we need one. They never volunteered. They never asked us and so we contend with the noise on a constant basis. Referring to resolution four, don't tell them to regulate hours, because only citizens should work regular hours. They work 24/7 and the noise is 34/7. Now, fracturing is a modern technology. Okay. So It's a modern technology, but what they don't tell you is that the wells are dangerous to health, life and limb. They release-the wells release methane gas. The always gas leaks that we're not told about. They cause considerable respiratory lung infection just to name a few. I appreciate it if you would give your consideration to the passing of resolution 17. Not just for the benefit of our residents, but for any resident who are affected by for the-by some of the same illnesses that we are. Thank you very much.

Peter Siska came before the Commission and gave the following comment:

I'm Professor at LSUS University and I live in Shreveport. Millicent Avenue 8510, almost five years. I'm also proud United States citizen. I'm here to speak in support of Commissioner Ken Epperson's Resolution 17. You may ask why. So, let me tell you quickly my reasons. First of all, I support the quality of life over anything and this resolution is about the quality of life and protecting of citizens qualities life, as we heard before. Also, this resolution is about preserving the natural environments, such as Cross Lake and the resources that we have here, water resources, municipal the source of municipal drinking water and also the air and everything that is in the environment. So, let me-why I'm supporting this resolution also let me show you a few articles. The first one that I have in my hand, and I can make it available, is about the cancer incidents in Louisiana and how they are-how are they linked to the industrial development, especially petrochemical industries. Cancer valley, between Baton Rouge and the New Orleans, and affect mostly impoverished people and Black communities. Another article clearly indicates that this economic development, the chemicals that we use in our environment, are getting into our genes already. So, we have generated transmitting. We are transmitting these problems or to next generation. Another one talks about the influence of chemicals in agriculture, and as a result of using these heavy chemicals in agriculture, we have Parkinson's disease. Feel free to check over that thing. So, when we look at the fracking industry, we have to think about those 20 million of liters of water that are pushed under force into these wells and for every well. So, there's millions and millions of waters that is being used and wasted. In addition, we have about 200,000 liters of chemicals that are mixed into this, and sand as well, to keep those fissures open. So, those chemicals are all kinds of assets and some of them are secrets that companies will never reveal that-what's inside. The problem is that one-fifth of them also comes back in these wells to the surface and influences the environment; and as the gentleman before me said methane ventilate. Venting methane is also part of this problem that increases the global warming quite significantly. So, we have all kinds of things that are associated with the fracking industry and it's not about being against economic development. No. We want the economic development to continue, however, we want to have a balance. We have to know when is enough. We can't just go forever with something and destroying our life of our future generations. I'm going to finish it very quickly now. So, I believe that this resolution 17 is quite reasonable. It's not asking really for too much. Staying 1000 feet away from the private property of industries is-it's reasonable. It's not something that would be drastically changing the life and destroying the economic development. Not at all. The economic development will continue in this regard. It's just asking the question, what is reasonable? When is-what

is the about the balance in our lives? We have balance. The balance is extremely critical for our life to keep in everything. So, I'm for this balance and I'm for this resolution and I would like to support it. Thank you.

Francis Kelly came before the Commission and gave the following comment:

I don't want to take long. I will be available later if you guys have questions when it comes time for that. I think the main thing I want to emphasize is that there have been multiple, multiple news reports by both state and national media, very respected organizations, such as the Southern Poverty Law Center, Freedom for Immigrants, have filed multiple civil rights complains about these abuses that have happened in detention. And there is-are allegations that the private prison companies that have contracts with I.C.E. are not delivering on the service that U.S. taxpayers are paying for them to deliver. And so, I think that this resolution is calling for the White House to take steps to address this and look into these allegations, and for the Chair of the Homeland Security Committee in Congress to look into these multiple, multiple allegations of abuses and misuse of government funds. So, I hope that you guys will support this resolution. Thank you.

Damion Humphries came before the Commission and gave the following comment:

Thank you, Mr. Atkins. We thank you for the prompt, the opportunity, the privilege to be here to stand before you on today. Standing today to speak on behalf of our organization, which is Image Changes nonprofit organization. But, first of all let me just introduce myself to the Commission. I am Damon L. Humphrey, Sr. Home address is 8820 Blanchard Furr Road, Shreveport, La. Live in District 1, but our organization serves in Commission-in District 2, where Commissioner Johnson is, and just to, and of course, we have representatives of those who have the same church on that I have on today. We are representing the organization Image Changers and Image Changers is a non-profit 501c3 organization, but we have been in existence for the year-since the year of 2006. And since that time with partnership with the City of Shreveport and, also, well in working with the Commissioners, Caddo Parish Commission, we have helped the citizens of Caddo Parish with housing and also with education by tutoring. Now, we have submitted an application and I do believe that it is listed in Ordinance No. 6165, and our desire is to continue the great work that we have started within the Parish. With our partnership with the City of Shreveport, we have built five homes in the MLK area and those five homes are occupied with person who are of low-income, moderate income means, and these are homes that are brick homes. Homes that have been established and built by contractors of Caddo Parish. Now, we are instrumental in getting this done and then we identified with the partnership working with the City of Shreveport and of course, with many financial institutions have here in our fair City. What we do is vet those persons who are desiring to become homeowners to ensure that they are first qualified and that they can obtain a loan to be able to move into those homes. And so, although that's done with the partnerships of various institutions and then those who are financial counselors to help those persons to become homeowners. So, we want to ensure that we have a win-win situation going on. So, we are presenting and asking that—We are asking that the Commission will show a favorable vote towards Image Changes and receiving the fund that's necessary to keep our good work going. And that the citizens of Shreveport will become homeowners. Many of them who are desiring to become homeowners and then those are many of the properties that are vacant then they will be off of the tax rolls where the City or the Parish has taken the beat on that of having to pay for additional taxes. Thank you so much. All right, thank you. Any Questions?

Jake Brown came before the Commission and gave the following comment:

Hey, how you all doing? My name is Jake Brown. I live out on Cross Lake. I'm one of the Board Members for Caddo Alliance for Freedom and the main question that I have is, why are we making the same mistake? And to look into that I kind of think we need to look at why the system failed us to begin with. And, I mean, we came here because we had tons of property members that were getting ticketed and it was for, you know, four-wheelers. It was for boats. It was for, you know, not being able to put a trailer because yours burnt down and now you've been rezoned with not proper notification. So, all this stuff happened and the City saw money signs. So, I mean, we were the perfect group to go after. I mean, we drive around Shreveport every day and we see code violations, I mean, all over the place. But, you know, some of those areas might not be able to pay those fines. So, you have this Metropolitan Planning Commission and the MPC that were going out there and ticketing us, because they thought we would just pay those fines. And, you know, we didn't-I didn't even know at the time that I had lost all my property rights. And, you know, I go and start looking and reading because, I mean, I do oil and gas a lot. So, I read a lot of legal. I have to deal with attorneys on a daily basis. So, I started going through all this and I was just like holy moly. I just moved back from California and now we pretty much have the same zoning in the same plan that they have. And I'm actually flying out to California monthly now and I'm dealing with rural landowners in Sacramento. They're kind of battling this same fight. So, you know, we started looking at it and we came to you guys to, hopefully, try to fix it and we were told that it wasn't possible. That we had to change the state law. And, so, luckily, we got Danny McCormick on board and he went through and helped us drafted HB 697. And we went down, we spoke at the House, and, you know, that it passed Committee, but that vote was split. So, I mean, the Republicans voted for it. Most of the Democrats voted against it, but it still passed. So, it moved on to the Senate. So, we went to the Senate committee and we got through that. We had to go back twice. So, we went first for the agricultural because the planning one wouldn't hear it. And so we drove down there, took off time from work. I went and spoke. And right when I was driving into the driveway to go eat dinner with my wife, I was told I had to go back down, because now since it got heard by the agricultural committee that wasn't the right

committee. So, then they moved us to the Planning and Zoning Committee and so I had to drive all the way back down to speak at that well it ended up passing and it went to the Senate floor. And, I couldn't believe it, but we got votes from both sides of the aisle. There wasn't one Democrat that voted against us. There wasn't one Republican that voted against us. So, we go back we look at this and I'm just like, how did the Senate pass this? And the main reason was, because they realized, we were the minority. You know? And we were getting abused by the majority. You know, at the time City Council got to appoint members and the Rural Commission got to point members. We don't get to vote for City Council, and so they saw that we were always going to be the minority, and the same thing's happening again. I mean, we've got this board that you all want to put in place this rural planning board. And its not going to work. I mean, these appointments. You've got one Commissioner, which I won't name, but he's appointed. He wanted to appoint someone from Greenwood. And he-one percent of his people are in the rural area. So how is he wanting to appoint somebody to this board when he told me that he doesn't have a dog in the fight, and to get Danny McCormick to fix this. And y'all need to just go about your business. So, you got him doing that. I mean, I was watching just the last meeting you guys had. I think it might have been Long Range or something. You had another Commissioner that's mad because his area is all in the City. He doesn't get to put someone on this rural planning board. So you got all these City Commissioners, while I'm sitting out there, the minority, wanting to put people on this board. So, what's going to happen? This board is going to become the same thing it was before. I mean, it's already happening and we're going to have a board that's going to do the City's bidding and we're going to be in the same boat. Now, if that does happen, I'm already too invested in this thing. I mean, I've spent a lot of money on my house. I'm here. I moved here, moved back from California. I'm not going to give up. I'm going to keep coming down here. I'm going to keep fighting for what I believe is right, and honestly, honestly, I think we're to the point now that we really need to wait and see what the Attorney General has to say. Because there's a lot of questions. I mean, I've got Parish Attorney's saying one thing and, honestly, it's an opinion. They're not giving case precedent. They're not really giving us the statues. You read the statues and, yeah, it says maybe you need this board, but maybe you don't. it's all in the verbiage. And, you know, I don't really think we do. And, you know, I know they say we got to have a board appointed to get rid of the master plan and to get rid of the UDC and then the board can dismantle. Didn't we already have this board? Wasn't that the Citizen's Advisory Committee? Wasn't that an appointed board and didn't they recommend no planning and zoning. Like I thought that's what happened. But like that's what the people wanted and we're back to this rural planning board. It's just not going to work and I just see this is just going to be a problem that you all are going to have to keep dealing with and all I'm trying to do is protect my property.

Jayne Tappe came before the Commission and gave the following comment:

Hello y'all. Okay, I'm going to bring it down to a level that is so elementary that if you all can't answer the question now it's going to be really bad. Okay ? So, I had a conversation today with a colleague of mine in the real estate world, and we were speaking about how what's going on here and what's been going on for the past couple years, how it affects us as realtors and how it affects property owners. She said, so what did you do about it? I said, well we went to them and expressed our problem. They told us what to do to fix it and we did it. And she said, so did that not solve the problem. I said, we thought it did. She said, so why is there still a problem? I said, I don't know. She said, there must be an agenda on the other side. I-she said, what is their goal? I said, I don't know. She said, I guess we need to ask them directly. What is the point of what you are doing? Can any one of the twelve of you look us here, in this room, in the eye, and answer why are we still doing this? And with that response can you make It make sense, so that I can explain it to someone else who doesn't know and been following this for two years. What exactly is going on here. Basically, why are you not trying to actually serve the people who live in the rural areas? It really is a simple question. Why is the answer not so simple? Thank you.

Bruce Deville came before the Commission and gave the following comment:

I'm asking the same thing. What's the agenda? What do we don't know? What are we fighting this same fight all over again? Why are we wasting your time and our time on a battle we're going to win? Why? Why are you trying to take our rural homes and do something with it? If we wanted to live in that big open sewer called the City of Shreveport, we would have moved there. We don't live there. We don't want to live there. Thank you.

Randy Rassmussen came before the Commission and gave the following comment:

I'm in the zone in question here. And a couple of things that hit me, I understood that this passage of 697 was going to revert outside the City limits to the Parish ordinances. Now, I've heard all of you, several of you, say well that isn't going to work. I'm like why not? There's noise ordinance to take care of noise problems. There's EPA take care of smell problems. There's just all kinds of things that'll take care of everything I've heard every one of you all say. So, why can't we go back to that, and then if we need to area by area, add in a zoning or whatever in that particular area? So simple. I mean, come on. I've been seeing just down the street from me there's a big new subdivision going in. It's got quarter acre lots. I'm like what? What the heck's that about? Why are they doing that? They need to be more fitting in the area they're building in. If they want to be in the city limits, be in the city limits. I mean, there's you've got hundreds, if not thousands, of adjudicated properties in the City limits. Why not build those areas and put those subdivisions there? Just drive down 70th street one day from the Red River all the way to the airport. You'll be appalled at what you see there. It's and the whole big areas over there that

could be redeveloped. I mean what's up with this. To me, it looks like you guys are doing the bidding of the people with money in town that want to build these pretty subdivisions. Well you know what, we don't want those big pretty subdivisions out in the rural areas. They need to be in the City, because a) the city needs revenue to maintain their—infrastructure because you got miles, you're getting to where you've got a lot of space between the more people you have in a mile stretch the more revenue the City gets for it. This makes no sense to me why we're building outside the City when there's all that going on. So, why can't we just go back to Parish ordinance for outside the City limits, period. Do away with the zoning that's out there now, and, as section by section as you need to come in and put it up. There's no reason to put everybody under all tis mess. That's what we were fighting against to start with, and now it sounds like all I'm hearing is insults from various Commissioners that don't think we know what we're doing or we're just some small rag tag group that doesn't know what's going on. Excuse me. We do know what's going on. We do know what we want. I feel totally insulted by those Commissioner that said those statements. So, anyway just please let us have our property rights. Just put us under the Parish zoning and we'll work from there simple. You're making it way too complicated. Thank you.

John Milkovich came before the Commission and gave the following comment:

I'm sure we'll all do better if I don't take the full three minutes. But, John Malkovich, Keithville, Louisiana. Mr. President, Commissioners. Look, I have confidence in this Commission, in your wisdom and courage, that you will shatter the incremental enforcement of the UDC. I'm hearing horror stories about the plans and even the beginnings of an effort to unleash an army of carport cops, overreaching officials and a rigged one-sized kangaroo environmental court where the judge is appointed and hired by the City. And, what is the purpose to fine, levy, regulate, intimidate, and charge us for horses, roosters, fences, carports, driveways, chicken coops and leaves on the roof? What I've been hearing form the people of Northwest Louisiana, particularly Caddo Parish, is we don't need regulations on our horses and roosters and chickens and chicken coops. Our community doesn't have too many horses. We've got too many homicides. Our concern is not carports, it's car burglaries, car thefts and carjacking. We're not worried about the condition of driveway, so much as we're concerned about drive-by. I feel like we need to allocate our resources on the true problem in Caddo Parish and, which includes Shreveport, is crime. I understand that much of that is a City municipal problem, but we feel like we need to be putting our resources where our primary problem is. It's not crumbling down out buildings. It's not crooked, cracked sidewalks. It's not too many horses in the pasture. It's the crime in Shreveport. And I believe that it's time for the Parish to be working closely with the City to come up with concrete solutions for the real problems. And if we don't have the money in Caddo Parish, in the City of Shreveport, to adequately pay our police officers, what in the world are we doing hiring an army of carport cops. I think it's time we get back to the business of the people. And let me say this, you know, we heard the horror stories. We understand the master plan we understand that this part of agenda 21. People get it, but that is not government of the people by the people for the people. That's government at the people. Government against the people. Government attacking the people. And I want to be very clear on the record, I've heard people suggest well some of these oppressive measures may be okay for inside the City limits, but not in the Parish. I want to be very clear that I'm as against these overreaching environmental, overzealous pantry police and car port cops in Cedar Grove, Allendale, Mooretown, MLK, Southern Highlands, Ellerbe Road, at Pierremont, as I am against those measures in Springridge, Keithville, Hosston, Ida, Blanchard, and Oil City. And I hope that the people that have generated and originated this agenda 21 agenda and their efforts to divide the people, I hope that it doesn't. I hope that the people that live in the City and the people that live in the rural areas will work together to protect the property rights and the freedoms of all of us. Thank you so much, Mr. President, and thank you very much Commissioners.

#### **ADOPT REGULAR SESSION MINUTES**

It was **moved by Mr. Johnson**, seconded by Mr. Chavez, *that Special Session Minutes—Property Standards January 20, 2022 and Regular Session Minutes January 20, 2022* be adopted. Motion carried.

#### **SPECIAL RESOLUTIONS**

It was **moved by Mr. Epperson**, seconded by Mr. Burrell, *that Special Resolution of Remembrance for Mattie McCulloch* be adopted.

Mr. Epperson said that Ms. McCulloch was so well-liked that four different services had to be had for her. He said that she was a matriarch for the community and loved everyone. She will be missed. Mr. Burrell agreed with Mr. Epperson and said that she was very much involved in the church and community.

**Substitute motion by Mr. Jackson**, seconded by Mr. Lazarus, *to englobo and adopt the following special resolutions:*

- *Special Resolution Proclaiming Black History Month*
- *Special Resolution of Remembrance for Mattie McCulloch*

- *Special Resolution Honoring Dr. Umar Johnson*
- *Special Resolution Recognizing American Heart Month & National Wear Red Day*

At this time, Mr. Jackson's motion carried, as shown by the following roll call votes: AYES: Commissioners Atkins, Burrell, Chavez, Epperson, Gage-Watts, Hopkins, Jackson, Johnson, Jones, Lazarus, Taliaferro, and Young (12). NAYS: None (0). ABSENT: None (0). ABSTAIN: None (0).

**SPECIAL PROCLAMATION  
BLACK HISTORY MONTH**

WHEREAS, the month of February is internationally observed as Black History Month, also referred to as African-American History Month in the United States and Canada, an effort that has the purpose of focusing attention upon a long-neglected and overlooked, but important and consequential, segment of the historical record of the United States and more broadly, the African diaspora; and

WHEREAS, this celebration of the role and the contributions of African American and Black citizens of this parish, state and country throughout its history is a fitting and beneficial process that serves to enlighten all citizens, and to strengthen the fibers of the national fabric; and

WHEREAS, the observance of Black History Month calls our attention to the continued need to battle racism and build a society that lives up to its democratic ideals as well as to celebrate the many achievements and contributions made by African Americans to our economic, cultural, spiritual, and political development; and

WHEREAS, Black History Month grew out of the 1926 establishment of Negro History Week by Carter G. Woodson and the Association for the Study of African American Life and History, and has blossomed into today's month-long observance, the theme of which is Black Health and Wellness; and

NOW, THEREFORE, BE IT RESOLVED, by the Caddo Parish Commission, meeting in legal and regular session this 3rd day of February, 2022 that it does hereby proclaim February 2022 as:

**'BLACK HISTORY MONTH'**

in Caddo Parish, Louisiana, and urges all citizens to join with the Parish in recognition of this important month.

**RESOLUTION OF REMEMBRANCE & RESPECT  
MATTIE BREWER MCCULLOCH**

WHEREAS, the Caddo Parish Commission notes with deep regret the passing of individuals whose life and works have served as an example of the worthy values that benefit this community and this Parish, such an individual being Sister Mattie Brewer McCulloch who went to meet her heavenly father on January, 21, 2022; and

WHEREAS, Mrs. McCulloch was born in Coushatta, Louisiana to her beloved parents, Mr. Howard Brewer Sr. and Mrs. Elizabeth Speed Brewer; and

WHEREAS, Mrs. McCulloch accepted Christ as her personal Savior and began attending Pleasant Hill Baptist Church after relocating to Caddo Parish. She was a faithful member and served in various capacities, including Women of Destiny, Saints for Life Ministry, Ministry Director for the Samaritan Helping Hands, Secretary of the Choir, Matrons' Ministry, and teaching her Sunday School Class; and

WHEREAS, Mrs. McCulloch was also one of the original founders of the Willing Workers' Ministry, which provided clothing, food, and other items to those in need within the community. She always supported every ministry, every outreach, and every opportunity to spread the Lord's word. Mrs. McCulloch also established The Mattie L. McCulloch Educational Scholarship to provide funding for students who are aspiring to continue their higher learning education; and

WHEREAS, Mrs. McCulloch was a phenomenal leader, motivator, and educator. She never met a stranger and accepted all who crossed her path; and

WHEREAS, she is also remembered for the warmth of her smile, her wisdom, and by her devotion to her family, her church, and her community; she will truly be missed.

NOW, THEREFORE, BE IT RESOLVED, by the Caddo Parish Commission, that it does hereby express its deepest regrets at the passing of Sister Mattie Brewer McCulloch.

BE IT FURTHER RESOLVED, that the Commission does further convey to the family and friends of Mrs. McCulloch its sincerest expressions of sympathy and consolation, and the prayer that they will be comforted in the knowledge of life that continues beyond this vale.

**SPECIAL PROCLAMATION  
DR. UMAR JOHNSON**

WHEREAS, the Caddo Parish Commission is always pleased to recognize and honor those who seek to engaged and elevate the sons and daughters of Caddo Parish by sharing knowledge and perspectives to challenge them, provoke thought & conversation and encourage excellence; and

WHEREAS, DR. UMAR JOHNSON is such a person who, as a Doctor of Clinical Psychology and Certified School Psychologist is considered an expert on the education and mental health of Afrikan and Afrikan-American children and is a sought-after public speaker, pundit and influencer; and

WHEREAS, Johnson draws upon his professional and scholarly knowledge to discuss issues impacting the Black community using his brand of leadership that draws upon generations of personal lineage with kinsman such as Frederick Douglas and 7<sup>th</sup> AME Bishop Wyman to his celebrated role as the Prince of PanAfrikanism; and

WHEREAS, Johnson, also known by the surname Ifatunde, will honor Caddo Parish and the City of Shreveport with his appearance, lecture and book signing where he will present his lecture, "State of Emergency: The Special Education & ADHD Wars Against Black Boys" at Booker T. Washington High School on January 30<sup>th</sup> as well as signing his book, The Black Parent Advocate; and

NOW, THEREFORE, BE IT RESOLVED, by the Caddo Parish Commission, that it does hereby declare and recognize and proclaim January 30, 2022 to be:

*'DR. UMAR JOHNSON DAY'*

in Caddo Parish, Louisiana, in recognition and admiration of his notable achievements in Ministry and music.

**AMERICAN HEART MONTH**

WHEREAS, February is designated as American Heart Month; and

WHEREAS, the death rate from heart disease in the United States has fallen dramatically since the 1960's, a significant health victory. Heart disease remains a leading cause of death for both men and women in the United States and unfortunately Caddo Parish; and

WHEREAS, we have learned much about factors that contribute to heart disease, how to monitor those triggers, and ways to treat them. We know that individuals can live longer and better lives by refraining from tobacco use, maintaining an optimal blood pressure and healthy weight, eating a healthy diet, and exercising regularly. Innovative tools and online systems give people more access than ever to information they can use to make informed, health conscious choices; and

WHEREAS, scientific research and evidence-based interventions to prevent or treat heart attacks and strokes have played an important part in making improvements. Developments in technology and discovery of early markers of heart disease have allowed doctors to diagnose and treat disease sooner than ever before. American innovators continue to develop treatments in drugs, equipment and strategies to educate Americans to stay heart healthy; and

WHEREAS, this month we stand with the families and friends affected by heart disease, and we recognize the ongoing efforts of dedicated advocates, researchers, and health care providers who strive each day to raise the awareness about heart disease in Caddo Parish.

NOW, THEREFORE, BE IT RESOLVED, by the Caddo Parish Commission, meeting in legal and regular session this 3<sup>rd</sup> day of February, 2022 that it does hereby proclaim February 2022 as:

*'AMERICAN HEART MONTH'*

in Caddo Parish, Louisiana, and urges all citizens to join with the Parish in recognition of this important month and encourage participation in the tradition of Wear Red Day on the first Friday of February, February 4<sup>th</sup>, 2022 when everyone across the country is asked to don the color red in order to raise and spread awareness to help eradicate heart disease and stroke in millions of women across the nation.

It was **moved by Mr. Chavez**, seconded by Mrs. Gage-Watts, *to englobo and adopt the following special resolutions:*

- *Special Resolution Proclaiming Coach Shelly McMillian's 700th Career Win*

Mr. Chavez said that Coach McMillian taught children life lessons. You make this city and this parish better because you're in it, he said.

Mr. Atkins thanked Coach McMillian for her years of service and mentoring the youth of Caddo Parish.

- *Special Resolution Celebrating 75 years of Service from the Delta Lambda Omega Chapter of Alpha Kappa Alpha Sorority, Inc.*

Mr. Johnson appreciates the hard work this sorority does for the young women in this community.

Ms. Charlene Voorhies thanked the Commission for recognizing the sorority today.

Mr. Burrell said that this sorority does such great work for Caddo Parish.

At this time, Mr. Chavez's motion carried by acclamation.

### **RESOLUTION OF RECOGNITION & APPRECIATION COACH SHELLEY MCMILLIAN**

WHEREAS, the Caddo Parish Commission is pleased to acknowledge with pride the accomplishments of those Northwest Louisiana sons & daughters who have gone forth to attain success and distinction in the various endeavors they pursue, especially when those endeavors enrich our community across generations, leaving an indelible mark, and

WHEREAS, on January 25<sup>th</sup>, 2022, NWLA Soccer icon Shelley McMillian added a new distinction to her remarkable career when she earned her 700<sup>th</sup> career win, cementing her legacy as the winningest Soccer coach in Louisiana high school sports history, an accomplishment that now rests alongside her 26 District Coach of the Year honors, 8 All-City Coach of the Year awards, Louisiana Boys 1996 Coach of the Year and Louisiana 2010 Girls Coach of the Year; and

WHEREAS, McMillian's 30 years coaching in Northwest Louisiana have seen her in various roles from her current post with the Parkway Lady Panthers, a team that she not only came out of retirement to revive 3 years ago, but that she founded in 1990; to her time coaching the Loyola boys team to their first state title, founding the Loyola's girls team, or coaching both the boys and girls teams at Calvary. In each role she encouraged, guided, and lifted countless young men & women to reach farther, higher goals than they could have imagined as they stood strengthened by the support of McMillian's high standards, leadership, character, and faith; and

WHEREAS, before becoming the record setting coach that she is, McMillian earned her place in local soccer history as a player with Airline High School and Centenary College, where she is noted for scoring the first goal in the history of the Centenary Women's Soccer program. Outside of Soccer, McMillian has made significant and lasting contributions to our community through motivational speaking where her inspirational and faith guided words have encouraged audiences not to give up; her commitment to her family as a wife, mother, and daughter; and her work as CEO of Rock Solid with programs like Project Swim which responded to the tragic drowning of 6 area youth in 2010 by providing free swim lessons to over 15,000 Caddo area children; and

NOW, THEREFORE, BE IT RESOLVED, by the Caddo Parish Commission, meeting in legal and regular session this 3rd day of February, 2022, that it does hereby declare and proclaim February 15, 2022 to be

#### **' SHELLEY MCMILLIAN DAY'**

in Caddo Parish, Louisiana, in recognition and admiration of her notable achievements and distinguished life.

BE IT FURTHER RESOLVED, that this Caddo Parish Commission does encourage all citizens of Caddo Parish to celebrate the great honor that Coach McMillian's accomplishments bring to our area by encouraging someone not give up, letting someone know that you believe that they can achieve their best or otherwise sharing McMillian's brand of positivity with the world.

### **RESOLUTION OF RECOGNITION & APPRECIATION ALPHA KAPPA ALPHA SORORITY**

WHEREAS, the Caddo Parish Commission is pleased to acknowledge events of significance that occur in the community, and to recognize the organizations and individuals who are now and for a long time have been in the forefront of positive and worthy activities and deeds that accrue to the benefit of all; and

WHEREAS, such an organization is the Alpha Kappa Alpha Sorority, Incorporated's Delta Lambda Omega Chapter in Shreveport, Louisiana who were chartered on February 3, 1947 and today celebrate their 75 Anniversary of dedicated and distinguished service since Mrs. Arnetta G. Wallace, who

served as the Regional Director, organized and chartered Delta Lambda Omega Chapter with chartered members Irma Green Jackson, Mae Etta Scott, Nannie Lou Leech, Zurline Baker, Mable Walker, Maxine Chambers and Hattie Fletcher; and

WHEREAS, the chapter's membership increased and along with continued growth, its priorities and goals expanded to serve Caddo, Bossier and DeSoto parishes. Their first Fundraiser was a piano concert by Lois Towles at Central Colored High School on November 18, 1947. Since 1949, Delta Lambda Omega has awarded annual scholarships during the James Sylvester Hall Senior Luncheon recognizes the top African American college bound girls from local schools. Delta Lambda Omega's members have proudly served on international, regional, and local levels in our esteemed sisterhood including Mrs. Dorothy S. Johnson (deceased) as the 15th South Central Regional Director and Ms. Tari T. Bradford as the 22nd South Central Regional Director; and

WHEREAS, Delta Lambda Omega Chapter has enthusiastically implemented a variety of programs, events, and educational offerings to enhance the lives of community members. The chapter is widely known for the Shoe Bank program, which provides shoes and socks for underprivileged school-aged students. In 2018, the chapter was acknowledged as one of the longest operational programs by the national organization, Reading is Fundamental (RIF) for sponsoring and implementing reading program and free book distributions for over 40 years. While celebrating the 112th Founders' Day of Alpha Kappa Alpha Sorority, Incorporated®, a Gala was held in February 2020, and a donation of \$3,000.00 was awarded to Southern University Shreveport and Grambling State University; and

WHEREAS, the chapter partnered with LSU Health Shreveport to host free mammograms in the Ivy Crown parking lot, supported American Heart Association with 2020's Pink Goes Red activity featuring heart healthy meals created by minority-owned small businesses, blood pressure checks & heart healthy exercises; an Alzheimer's support group at Morning Star Missionary Baptist Church Life Center; donations of eyeglasses to Lions Club International; donations of shoes in support of the Soles4Souls, financial donations to LSU Health Shreveport Office of Diversity Affairs, the American Cancer Society, the NWLA Sickle Cell Disease Association, the NAACP, the NW Food Bank and the Providence House's efforts to provide housing to women and their families experiencing homelessness; and

WHEREAS, under the 2022 Presidency of Mrs. Charlene M. Voorhies, Delta Lambda Omega Chapter has a membership of 281 and maintains a status as a premier chapter, offering educational programs, academic scholarships, and striving to make a positive change and support like-minded organizations.

NOW, THEREFORE, BE IT RESOLVED, by the Caddo Parish Commission in legal session convened, that it does hereby proclaim and recognize February 3, 2022 as:

*"Alpha Kappa Alpha Incorporated's Delta Lambda Omega Chapter Day"*

in Caddo Parish, Louisiana, entreating all citizens of the Parish to join in applauding this observance and in honoring Alpha Kappa Alpha Sorority's Delta Lambda Omega Chapter and its members.

#### **COMMUNIQES & COMMITTEE REPORTS**

- Mr. Jackson wanted to know if the research for the Red River Waterway Commission has been completed. Dr. Wilson said that it has not.
- Mr. Johnson announced that the NGO and ARP will meet next week.
- Mr. Jones would like to know if there is anything that the Commission can do with regards to getting people out of the incoming inclement weather.
- Mr. Epperson announced that the Overton Brooks VA Medical Center will provide free COVID testing for veterans, Monday through Friday from 10:00 a.m. until 2:00 p.m.

#### **ADMINISTRATOR REPORT**

- Pulse of the Parish  
Dr. Wilson announced that the Pulse of the Parish will air on the first Friday of each month at 12:00 noon. He asked that everyone tune into the broadcasts.
- Shreveport-Bossier Sports Commission  
Dr. Wilson also presented a plaque that the Commission received from the Shreveport-Bossier Sports Commission thanking Public Works and Parks & Recreation for their assistance with a project in Camp Minden.
- Equipment for Inclement Weather

Dr. Wilson provided a brochure of the equipment the Parish has. He also mentioned that some of the equipment is on back order because of the supply chain issues.

Mr. Johnson wanted to know if the snow plows came in. Dr. Wilson said that they have not. He also said that the vehicles had to be retrofitted to ensure the attachments work correctly. Mr. Johnson suggested utilizing a water tank truck to cover a larger area quickly. Dr. Wilson said that the Parish did have that at one time, but could not justify the expense since it was not

- Confederate Monument

Mr. Johnson wanted to know if there has been any headway on the contract with the Confederate Monument. Dr. Wilson said that he will provide that information tomorrow.

Mr. Jackson asked that the Confederate Monument be a part of the Administrator Report.

- Requests from the Commissioners

Mr. Young asked that Administration provide a budget for a back up system of water tanks that could be used to keep CCC sanitary in case of an emergency. Dr. Wilson will provide that information to Mr. Young.

Mr. Johnson asked that the Clerk of the Commission read the memo from the Parish Attorney's Office into the record:

HB No. 697 removed Caddo Parish territory from the jurisdiction of the Shreveport Metropolitan Planning Commission of Caddo Parish. Essentially, it undid a "legislative CEA" between the Parish and City of Shreveport for zoning functions. That statute did not become effective until 1/1/2022. The effective date is important because the Parish no longer has the procedures and boards in place to handle zoning issues and matters for the Parish. For instance, pending zoning cases must still be completed as well as new cases considered. Additionally, the Parish's zoning ordinances were not repealed. All zoning ordinances are in place and affecting citizens right now. This includes everything from site plans to zoning violations to rezoning. Furthermore, a board must be in place to hear appeals and make decisions on certain issues That is why the 2021 ordinance creating the Caddo Parish Planning board was passed. Until it is populated and starts holding hearings, development in the parish is affected and zoning matters are at a standstill – even those that arose before the legislation became effective - are halted.

Update as requested in 1/31/22 Work Session:

The following should be noted: 1) **FIVE-MILE RADIUS** 2) The five-mile planning area was established by parish ordinance. Since the Parish had and continues to have authority to zone, ordinances affecting property within the five-mile planning area were legally adopted and continue to be in effect. 3) **PROPERTY STANDARDS** property standards is entirely different from zoning. It does not regulate lane use, but regulates the condition in which property must be kept. Specifically, the property standards ordinances regulate the disposal of "waste" and "junk" on property, dilapidated buildings and structures, and grass height. The MPC staff never enforced the property standards ordinances. Initially, the constables and justice courts were chartered with enforcement, but that arrangement was unsatisfactory. Now, Caddo Parish personnel write citations which are turned over to the Caddo Parish DA if the violation isn't abated. The Caddo Parish property standards ordinances are contained in Sections 30-19 through 30-31 of the Code of Ordinances, available at [ARTICLE II.-DILAPIDATED AND DANGEROUS BUILDINGS AND STRUCTURES |Code of Ordinances| Caddo Parish, LA| Municode Library.](#)

Mr. Johnson said that elected officials are elected to do what is right for the Parish. He also mentioned that the five-mile radius is up to five miles, and in some areas it smaller than five miles. Mr. Johnson said that this still needs to be hashed out and vetted.

Mr. Jackson said that there was an incident at CCC with a prisoner hurting a female prison guard. He wanted to know if the Parish was liable for that. Attorney Bernstein said that the Parish owns the building, but it is not obligated to operate the building. Mr. Jackson then wanted to know if the Parish is liable for any non-parish employee who gets hurt at CCC. Attorney Bernstein said that the Parish is obligated to provide a jail, but the Sheriff is obligated to run it.

Mr. Jackson wanted to know if Grace Projects submitted their reports. Mrs. Barnett said that they have submitted it.

Mr. Chavez talked about planning and zoning in the Parish. He said that there are citizens who are stuck in the middle of the zoning process because there is no zoning board. Mr. Chavez wanted to know what they should tell their citizens. He also pointed out that the Attorney General's opinion is not binding. Dr. Wilson said that there is no process for a citizen who would like to get their

property rezoned, if they are in the Parish.

Mr. Epperson asked for the COVID report. He also asked that this be added to the Regular Session Administration Report. Dr. Wilson said that there have been 3 or more additional cases since Monday's report. He said that there have been several exposures and positive cases this week.

#### **PUBLIC HEARING ON ZONING ORDINANCES & CASES**

The President opened the floor for anyone to speak in favor or against the following ordinance:

- *Ordinance No. 6154 of 2021, in regards to Zoning Case 21-35-P, an ordinance to amend Volume II of the Code of Ordinances of the Parish of Caddo, as amended, the Caddo Parish Unified Development Code, by amending the zoning of property located on the west end of Sandi Acres Loop, Caddo Parish, LA., from RMHS, Residential Manufactured Home Subdivision District to R-A, Rural Agricultural District, and to otherwise provide with respect thereto*

There being no one to speak in favor or against the public hearing, the President closed the public hearing.

#### **PUBLIC HEARING ON ORDINANCES**

The President opened the floor for anyone to speak in favor or against the following ordinance:

- *Ordinance No. 6167 of 2022, an ordinance repealing Section 38-4 of the Code of Ordinances regarding the Shreveport-Caddo 2030 Master Plan and otherwise providing with respect thereto*

Chris Kracman came to the Commission in support of Ordinance No. 6167 of 2022. He gave the following comment:

I'm going to keep it short. So, we have ordinance 6167, the 2030 Master Plan Repeal in respect to Caddo Parish and Ordinance 6168 which repeals 6071, which is the appointed board. Which is questionable, the whole board thing. So, I'm going just keep it down on that, but this 2030 Master Plan business more or less how you all vote today, whether it be to postpone it or get rid of it or whatever the case may be, it should speak volumes where we stand on this deal. And its kind of like Resolution 32 of last year. It's going to make a statement of where we stand. And if it ends up being 6:6, then we know where we stand and it's probably going to end up in the courtroom. We don't want that, because we elected all of you to make a good decision here. Regardless of what you think. Or regardless of your personal opinion or political opinion. And I know we're going around and we're bragging about how we held off the UDC for however long and this and that, but at the end of the day, the people that are saying this voted for the UDC to begin with. It was unanimous vote. I don't care how long it was held off. So, this ordinance 6167 is a hell of a start to get to where we've been screaming for two years. If y'all can get rid of that then we're all on a good track. Now as far as this appointed board goes, like I said, I think it would be wise to probably wait on the Attorney General's opinion. However, like I've said a million times, that's only an opinion. That doesn't mean that everybody in this horseshoe is going to listen to it. And, again, if it ends up being 6:6 then I think we might know where we stand, and maybe you should not only wait on the Attorney General's opinion, maybe wait on our lawsuit. Because we're on the edge of our seat debating what we want to do. And I know everybody is trying to do the right thing, but the path to hell is paved with good intentions. And today's going to tell the tale on what we're doing. And the way that some people are or aren't looking at me right now tells the tale of where we're going.

- *Ordinance No. 6168 of 2022, an ordinance repealing Ordinance 6071 of 2021 relative to establishment of a Parish Planning Commission and otherwise providing with respect thereto*
- *Ordinance No. 6173 of 2022, an ordinance amending the 2022 Budget of Estimated Revenues and Expenditures for the Riverboat Fund and the Oil and Gas Fund to provide an additional appropriation for Urban Support and to otherwise provide with respect thereto*
- *Ordinance No. 6174 of 2022, an ordinance amending the 2021 Budget to amend the Budget of Estimated Revenues and Expenditures for the Head Start Fund and to otherwise provide with respect thereto*
- *Ordinance No. 6175 of 2022, an ordinance amending the 2021 Budget to amend the Budget of Estimated Revenues and Expenditures for the Section 8 Fund and to otherwise provide with respect thereto*

- *Ordinance No. 6176 of 2022, an ordinance amending the Budget of Estimated Revenues and Expenditures for the General Fund to provide an appropriation for Wheel Chair Ramp and Roof Repair Program and to otherwise provide with respect thereto*
- *Ordinance No. 6177 of 2022, an ordinance amending the Budget of Estimated Revenues and Expenditures for the Oil and Gas Fund and the Riverboat Fund to provide an appropriation of \$32,000 for a Mural Program and to otherwise provide with respect thereto*

Pam Atchison came before the Commission to speak in favor of Ordinance No. 6177 of 2022. She gave the following comment:

Thank you very much. Pam Atchison, Shreveport Regional Arts Council. 801 Crocket Street. Thank you, Mr. Chairman, Mr. President. Thank you also Commissioner Jackson for the whole Commission seriously considering the opportunity for the mural program. I'm here to speak to 6177, the mural program Put a Poem On it, that is conceived by your Poet Laureate Poetic X, who is very keen to see each district have an opportunity to have community meetings where your citizens, in your district, have a chance to talk about their priorities, what are their values, what's the history of the community, who are important leaders from the community, and what's the heritage that makes the each of your districts so unique. And then, subsequently, for him to be able to write a custom poem that deals with those issues reflects them in a very positive way and invite an artist to illustrate them and turn it into a mural that would go on a public building in each district. This allocation that you're considering would allow him to do three to four districts this year and I'm very hopeful that you'll approve it. Thank you so much for the opportunity.

- *Ordinance No. 6186 of 2022, an ordinance amending the Budget of Estimated Revenues and Expenditures for the E Edward Jones Housing Trust Fund for the year 2022 to appropriate funds received from the US Treasury in the amount of \$5,274,675 for the Emergency Rental Assistance Program and to otherwise provide with respect thereto*

Jon Glover came before the Commission with questions regarding Ordinance No. 6186 of 2022. She gave the following comment:

I was looking at public hearing ordinance for 6186 and 6187. First, the funds that you all are looking at, that you're receiving, the \$5 million plus dollars that was the federal grant or is the Commission going to be matching those dollars? Or not? Same thing with 6187. There are \$17 million in a grant that you all are going-you all are asking- to have appropriated as emergency rental assistance program. Now, I want to know too why the E. Edward Jones Trust Funding Housing Fund is that-does that allow every citizen in the Parish to apply with that name E. Edward Jones Housing Trust Fund? And two, how did the trust fund come to be?

- *Ordinance No. 6187 of 2022, an ordinance amending the Budget of Estimated Revenues and Expenditures for the E Edward Jones Housing Trust Fund for the year 2021 to appropriate Emergency Rental Assistance Program from the State of Louisiana and to otherwise provide with respect thereto*

Jon Glover came before the Commission with questions regarding Ordinance No. 6186 of 2022. She gave the following comment:

I know it, but it's dealing with both of those because I want to understand fully. Because I don't want to have any aspect of someone thinking that they're not a part of just because of terms or words that are used. And in this instance, E. Edward Jones Housing Trust Fund, I just want to know why that name and not maybe a generic name whereby it has no association with anything other than what the Commission itself is going to be supporting. And, again, the funding itself are you all at in either of these junctures going to be matching any funds, because you're asking for 2021 in 6187. That's \$17 million you're saying that you all are talking about appropriating for emergency rental assistance. Those dollars are available? Or are they not available?

Calvin Lester came before the Commission and gave the following comment:

I just want to come really briefly and thank the Commission for its support of affordable housing and organizations. I want to thank the Commission for its very, very forward looking proposal or actual legislation that set up the E. Edward Jones Housing Trust Fund to help in the areas of affordable housing. Those of us who practice and do this work know that in the City of Shreveport and Caddo Parish there's a necessity. We are down almost 10,000 units of affordable housing in the City and the Parish. And when you're talking about making communities safer, bringing up property standards, creating neighborhoods of choice and stabilizing neighborhoods that may have been on decline. Those are the things you're going to have to do. So, I just want to stand in support of 6172 and thank you for your forward thinking and can please continue to invest in some of these areas in our community. So, that we can have positive areas all over the City of Shreveport, and more importantly the Parish of Caddo. Thank

you very much.

- *Ordinance No. 6188 of 2022, an ordinance amending the Budget of Estimated Revenues for the American Rescue Plan Fund to provide an appropriation for Ring Doorbell Pilot Program in Caddo Parish and to otherwise provide with respect thereto*
- *Ordinance No. 6189 of 2022, an ordinance to enact Section 2-5 relative to parish owned or maintained buildings and offices, to provide that agencies, constitutional officers, or other political subdivisions occupying those buildings and offices shall report data regarding communicable diseases of concern to the public and to otherwise provide with respect thereto*

Jayne Tappe came before the Commission with question regarding Ordinance No. 6189 of 2022. She gave the following comment:

Yes, Jane Tappe on 6165 and 6189. And I just want to make sure there's no misunderstanding on these ERAP funds. And if I'm understanding it correctly, it says you'd like to amend the fund to provide an additional appropriation of 75,000 to for housing quality inspections. Up above that it says Whereas there have been reports of landlords receiving these funds and subsequently failing to maintain safe sanitary and secure housing. You got to understand the order of things. You got people living in houses for free. The system is paying that rent after the fact. The owners have had the property. They're trying to maintain the property. They're trying to take care of the property while these people are living in it, tearing it up and now you want to come back and do inspections after the people have torn it up, but before the homeowners have gotten that money to fix and repair. You got to get your horse and your cart in the right order and I want to make sure that that's looked at properly. In the right order that it happens. It's like you're punishing the owners for not taking care of the property that the people tore up, but the money didn't come until after they tore up, but you wanted to fix it before. Just kind of making that statement. And on 6189 I just this is so. All agencies constitutional officers or other political subdivisions that occupy facilities owned or maintained by the Parish shall report periodically to the Parish any occurrence of a communicable disease that is of concern. I surely hope you are not wanting your businesses, your building and your facilities to report every time somebody has the flu, if you do we're in even more trouble. So, I do hope your wording here is not what you mean. Thank you.

There being no one else to speak in favor or against the public hearings, the President closed the public hearing.

#### **ZONING ORDINANCES (for final passage)**

It was **moved by Mr. Epperson**, seconded by Mrs. Gage-Watts, *that Ordinance No. 6154 of 2021, in regards to Zoning Case 21-35-P, an ordinance to amend Volume II of the Code of Ordinances of the Parish of Caddo, as amended, the Caddo Parish Unified Development Code, by amending the zoning of property located on the west end of Sandi Acres Loop, Caddo Parish, LA., from RMHS, Residential Manufactured Home Subdivision District to R-A, Rural Agricultural District, and to otherwise provide with respect thereto* be adopted.

Mr. Epperson said that this went through the process, and there is no opposition regarding this case. He asked that the Commission adopt this Ordinance.

Mr. Young wanted to know if the Commission is legally able to act on this ordinance. Attorney Bernstein stated that the Commission is because the hearing went before the MPC in December when it still had jurisdiction.

At this time, Mr. Epperson's motion carried, as shown by the following roll call votes: AYES: Commissioners Atkins, Burrell, Chavez, Epperson, Gage-Watts, Hopkins, Jackson, Johnson, Jones, Lazarus, Taliaferro, and Young (12). NAYS: None (0). ABSENT: None (0). ABSTAIN: None (0).

#### **ORDINANCE NO. 6154 OF 2021, ZONING CASE 21-35-P**

BY THE CADDO PARISH COMMISSION:

AN ORDINANCE TO AMEND VOLUME II OF THE CODE OF ORDINANCES OF THE PARISH OF CADDO, AS AMENDED, THE CADDO PARISH UNIFIED DEVELOPMENT CODE, BY AMENDING THE ZONING OF PROPERTY LOCATED ON THE WEST END OF SANDI ACRES LOOP, CADDO PARISH, LA., FROM R- MHS, RESIDENTIAL MANUFACTURED HOME SUBDIVISION DISTRICT TO R-A, RURAL- AGRICULTURAL DISTRICT, AND TO OTHERWISE PROVIDE WITH RESPECT THERETO

BE IT ORDAINED by the Caddo Parish Commission in due, legal and regular session convened, that Volume II of the Code of Ordinances of the Parish of Caddo, as amended, the Caddo Parish Unified Development Code, is hereby amended and re-enacted to read as follows, to wit:

The official Zoning Map of the Shreveport Metropolitan Planning Area of Caddo Parish, Louisiana, be amended by rezoning property located on the west end of Sandi Acres Loop, Caddo Parish, LA, more particularly described below, be and the same is hereby amended from R-MHS, Residential Manufactured Home Subdivision District to R-A, Rural-Agricultural District:

12.996 ACS. M/L-LOT 1, SCHLEBEN HOLLOW, SECTION 12, T16N, R16W, CADDO PARISH, LOUISIANA.

BE IT FURTHER ORDAINED, that if any provision or item of this ordinance or the application thereof is held invalid, such invalidity shall not affect other provisions, items or applications which can be given effect without the invalid provisions, items or applications, and to this end, the provisions of this ordinance are hereby declared severable.

BE IT FURTHER ORDAINED that this ordinance shall become effective ten (10) days after publication in the official journal.

BE IT FURTHER ORDAINED, that all ordinances or parts thereof in conflict herewith are hereby repealed.

### **ORDINANCES (for final passage)**

It was **moved by Mr. Burrell**, seconded by Mr. Jackson, *that Ordinance No. 6155 of 2022, an ordinance amending the Budget of Estimated Revenues and Expenditures for the Economic Development Fund in the amount of \$5,000 to provide an additional appropriation for the Delta Upsilon Lambda Foundation and to otherwise provide with respect thereto* be adopted.

**Substitute motion by Mr. Johnson**, seconded by Mr. Jackson, *to englobo and adopt the following ordinances:*

- *Ordinance No. 6155 of 2022, an ordinance amending the Budget of Estimated Revenues and Expenditures for the Economic Development Fund in the amount of \$5,000 to provide an additional appropriation for the Delta Upsilon Lambda Foundation and to otherwise provide with respect thereto*
- *Ordinance No. 6156 of 2022, an ordinance amending the Budget of Estimated Revenues and Expenditures for the Economic Development Fund in the amount of \$5,000 to provide an additional appropriation for the Dress for Success Shreveport-Bossier and to otherwise provide with respect thereto*
- *Ordinance No. 6158 of 2022, an ordinance amending the Budget of Estimated Revenues and Expenditures for the Economic Development Fund in the amount of \$5,000 to provide an appropriation for Friends in Unity and to otherwise provide with respect thereto*
- *Ordinance No. 6159 of 2022, an ordinance amending the Budget of Estimated Revenues and Expenditures for the Economic Development Fund in the amount of \$10,000 to reduce the appropriation for the Playaz and Playettes, Inc and to otherwise provide with respect thereto*

**Amendment by Mr. Jackson**, seconded by Mr. Lazarus, *to include the following ordinances in the englobo:*

- *Ordinance No. 6160 of 2022, an ordinance amending the Budget of Estimated Revenues and Expenditures for the Oil and Gas Fund for the year 2022 to provide an appropriation of \$109,000 to provide Caddo Fire District 7 with a part time employee, and to otherwise provide with respect thereto*
- *Ordinance No. 6161 of 2022, an ordinance amending the Budget of Estimated Revenues for the American Rescue Plan Fund to provide an appropriation of up to \$30,000 for Red G Enterprises and to otherwise provide with respect thereto*
- *Ordinance No. 6162 of 2022, an ordinance amending the Budget of Estimated Revenues for the American Rescue Plan Fund to provide an appropriation for counseling in public high schools in Caddo Parish and to otherwise provide with respect thereto*
- *Ordinance No. 6163 of 2022, an ordinance amending the Budget of Estimated Revenues for the American Rescue Plan Fund to provide an appropriation for Volunteers for Youth Justice for truancy and to otherwise provide with respect thereto*

- *Ordinance No. 6164 of 2022, an ordinance amending the Budget of Estimated Revenues for the American Rescue Plan Fund to provide an appropriation for Caddo Parish Juvenile Court and to otherwise provide with respect thereto*

At this time, Mr. Johnson's motion carried as amended, as shown by the following roll call votes: AYES: Commissioners Atkins, Burrell, Chavez, Epperson, Gage-Watts, Jackson, Johnson, Jones, Lazarus, Taliaferro, and Young (12). NAYS: None (0). ABSENT: None (0). ABSTAIN: None (0).

**ORDINANCE NO. 6155 OF 2022**

BY THE CADDO PARISH COMMISSION:

AN ORDINANCE AMENDING THE BUDGET OF ESTIMATED REVENUES AND EXPENDITURES FOR THE ECONOMIC DEVELOPMENT FUND IN THE AMOUNT OF \$5,000 TO PROVIDE AN ADDITIONAL APPROPRIATION FOR THE DELTA UPSILON LAMBDA FOUNDATION AND TO OTHERWISE PROVIDE WITH RESPECT THERETO

WHEREAS, the Caddo Parish Commission appropriated \$5,000 in its 2022 budget for Delta Upsilon Lambda Foundation program; and

WHEREAS, Delta Upsilon Lambda Foundation will use the funds for an after-school program to prepare high school students for the real world; and

WHEREAS, the Caddo Parish Commission would like to amend the 2022 Economic Development Fund Budget to provide a total appropriation of \$10,000 for Delta Upsilon Lambda Foundation; and

WHEREAS, this amendment is recommended by the Economic Development committee; and

NOW, THEREFORE, BE IT ORDAINED, by the Caddo Parish Commission in due, legal and regular session convened, that Budget of Estimated Revenues and Expenditures for the Economic Development Fund for the year 2022 is hereby amended as follows:

	<u>Budget Increase (Decrease)</u>
<u>Economic Development Fund</u>	
NGO Appropriations	
Delta Upsilon Lambda Foundation	\$5,000
Fund Balance	(\$5,000)

BE IT FURTHER ORDAINED, that if any provision or item of this ordinance or the application thereof is held invalid, such invalidity shall not affect other provisions, items or applications which can be given effect without the invalid provisions, items or applications, and to this end the provisions of this ordinance are hereby declared severable.

BE IT FURTHER ORDAINED, that this ordinance shall take effect upon adoption.

BE IT FURTHER ORDAINED, that all ordinances or parts thereof in conflict herewith are hereby repealed.

**ORDINANCE NO. 6156 OF 2022**

BY THE CADDO PARISH COMMISSION:

AN ORDINANCE AMENDING THE BUDGET OF ESTIMATED REVENUES AND EXPENDITURES FOR THE ECONOMIC DEVELOPMENT FUND IN THE AMOUNT OF \$5,000 TO PROVIDE AN ADDITIONAL APPROPRIATION FOR THE DRESS FOR SUCCESS SHREVEPORT-BOSSIER AND TO OTHERWISE PROVIDE WITH RESPECT THERETO

WHEREAS, the Caddo Parish Commission appropriated \$5,000 in its 2022 budget for Dress for Success program; and

WHEREAS, the mission for Dress for Success is to empower women to achieve independence by providing a network of support, professional attire and the development of tools to help women thrive in work and in life; and

WHEREAS, the Caddo Parish Commission would like to amend the 2022 Economic Development Fund Budget to provide a total appropriation of \$10,000 for Dress for Success; and

WHEREAS, this amendment is recommended by the Economic Development committee;  
and

NOW, THEREFORE, BE IT ORDAINED, by the Caddo Parish Commission in due, legal and regular session convened, that Budget of Estimated Revenues and Expenditures for the Economic Development Fund for the year 2022 is hereby amended as follows:

<u>Economic Development Fund</u>	<u>Budget Increase (Decrease)</u>
NGO Appropriations	
Dress for Success	\$5,000
Fund Balance	(\$5,000)

BE IT FURTHER ORDAINED, that if any provision or item of this ordinance or the application thereof is held invalid, such invalidity shall not affect other provisions, items or applications which can be given effect without the invalid provisions, items or applications, and to this end the provisions of this ordinance are hereby declared severable.

BE IT FURTHER ORDAINED, that this ordinance shall take effect upon adoption.

BE IT FURTHER ORDAINED, that all ordinances or parts thereof in conflict herewith are hereby repealed.

**ORDINANCE NO. 6158 OF 2022**

BY THE CADDO PARISH COMMISSION:

AN ORDINANCE AMENDING THE BUDGET OF ESTIMATED REVENUES AND EXPENDITURES FOR THE ECONOMIC DEVELOPMENT FUND IN THE AMOUNT OF \$5,000 TO PROVIDE AN APPROPRIATION FOR FRIENDS IN UNITY AND TO OTHERWISE PROVIDE WITH RESPECT THERETO

WHEREAS, the Caddo Parish Commission would like to appropriate \$5,000 in its 2022 budget for Friends in Unity; and

WHEREAS, Friends in Unity is a strong advocate for the community educational and revitalization of Allendale, Lakeside and contiguous communities; and

WHEREAS, Friends in Unity will conduct job fairs, college fairs and financial literacy workshops to benefit the residents of this community; and

WHEREAS, this amendment is recommended by the Economic Development committee;  
and

NOW, THEREFORE, BE IT ORDAINED, by the Caddo Parish Commission in due, legal and regular session convened, that Budget of Estimated Revenues and Expenditures for the Economic Development Fund for the year 2022 is hereby amended as follows:

<u>Economic Development Fund</u>	<u>Budget Increase (Decrease)</u>
NGO Appropriations	
Friends in Unity	\$5,000
Fund Balance	(\$5,000)

BE IT FURTHER ORDAINED, that if any provision or item of this ordinance or the application thereof is held invalid, such invalidity shall not affect other provisions, items or applications which can be given effect without the invalid provisions, items or applications, and to this end the provisions of this ordinance are hereby declared severable.

BE IT FURTHER ORDAINED, that this ordinance shall take effect upon adoption.

BE IT FURTHER ORDAINED, that all ordinances or parts thereof in conflict herewith are hereby repealed.

**ORDINANCE NO. 6159 OF 2022**

BY THE CADDO PARISH COMMISSION:

AN ORDINANCE AMENDING THE BUDGET OF ESTIMATED REVENUES AND EXPENDITURES FOR THE ECONOMIC

DEVELOPMENT FUND IN THE AMOUNT OF \$10,000 TO REDUCE THE APPROPRIATION FOR THE PLAYAZ AND PLAYETTES, INC AND TO OTHERWISE PROVIDE WITH RESPECT THERETO

WHEREAS, the Caddo Parish Commission appropriated \$20,000 in its 2022 budget for Playaz and Playettes, Inc program; and

WHEREAS, Playaz and Playettes, Inc will use the funds the Shreveport Blues and Southern Soul Pre-Labor Day Festival; and

WHEREAS, the Caddo Parish Commission would like to reduce the 2022 Economic Development Fund Budget to provide a total appropriation of \$10,000 for Playaz and Playettes, Inc; and

WHEREAS, this amendment is recommended by the Economic Development committee; and

NOW, THEREFORE, BE IT ORDAINED, by the Caddo Parish Commission in due, legal and regular session convened, that Budget of Estimated Revenues and Expenditures for the Economic Development Fund for the year 2022 is hereby amended as follows:

	<u>Budget Increase (Decrease)</u>
<u>Economic Development Fund</u>	
NGO Appropriations	
Playaz and Playettes, Inc	(\$10,000)
Fund Balance	\$10,000

BE IT FURTHER ORDAINED, that if any provision or item of this ordinance or the application thereof is held invalid, such invalidity shall not affect other provisions, items or applications which can be given effect without the invalid provisions, items or applications, and to this end the provisions of this ordinance are hereby declared severable.

BE IT FURTHER ORDAINED, that this ordinance shall take effect upon adoption.

BE IT FURTHER ORDAINED, that all ordinances or parts thereof in conflict herewith are hereby repealed.

**ORDINANCE NO. 6160 OF 2022**

BY THE CADDO PARISH COMMISSION:

AN ORDINANCE AMENDING THE BUDGET OF ESTIMATED REVENUES AND EXPENDITURES FOR THE OIL AND GAS FUND FOR THE YEAR 2022 TO PROVIDE AN APPROPRIATION OF \$109,000 TO PROVIDE CADDO FIRE DISTRICT 7 WITH A PART TIME EMPLOYEE, AND TO OTHERWISE PROVIDE WITH RESPECT THERETO

WHEREAS, The Caddo Fire District 7 (CFD7) currently only has onsite employees at the Oil City station; and

WHEREAS, the Highway 1 bridge and the Highway 530 bridge are temporarily closed in Fire District 7 and delaying services to CFD7 citizens; and

WHEREAS, CFD7 would like to add part time employees to help cover shifts in order to staff the Belcher and Mooringsport Fire Stations; and

WHEREAS, the Caddo Parish Commission would like to appropriate \$109,000 to pay for part-time employees for one year while bridges are closed.; and

NOW, THEREFORE, BE IT ORDAINED, by the Caddo Parish Commission in due, legal and regular session convened, that Budget of Estimated Revenues and Expenditures for the Oil and Gas Fund for the year 2022 is hereby amended as follows:

	<u>Budget Increase (Decrease)</u>
<u>Oil &amp; Gas Fund</u>	
Allocations to Other Entities	
Fire District 7	\$109,000
Fund Balance	\$(109,000)

BE IT FURTHER ORDAINED, that if any provision or item of this ordinance or the application thereof is held invalid, such invalidity shall not affect other provisions, items or applications which can be given effect without the invalid provisions, items or applications, and to this end the provisions of this ordinance are hereby declared severable.

BE IT FURTHER ORDAINED, that this ordinance shall take effect upon adoption.

BE IT FURTHER ORDAINED, that all ordinances or parts thereof in conflict herewith are hereby repealed.

**ORDINANCE NO. 6161 OF 2022**

BY THE CADDO PARISH COMMISSION:

AN ORDINANCE AMENDING THE BUDGET OF ESTIMATED REVENUES FOR THE AMERICAN RESCUE PLAN FUND TO PROVIDE AN APPROPRIATION OF UP TO \$30,000 FOR RED G ENTERPRISES AND TO OTHERWISE PROVIDE WITH RESPECT THERETO

WHEREAS, the American Rescue Plan Act of 2021 (ARPA) became law on March 11, 2021; and

WHEREAS, Caddo Parish Commission would like to re-appropriate up to \$30,000 to provide for revenue replacement for Red G Enterprises; and

WHEREAS, Ordinance 6114 of 2021 originally appropriated funds for Red G Enterprises; and

WHEREAS, the budget lapsed at the end of 2021; and

WHEREAS, the Red G Enterprises was unable to rent their facility in 2020 due to the COVID-19 pandemic; and

WHEREAS, the revenue replacement funding is needed to continue to provide this service to the area; and

WHEREAS, this amendment is recommended by the American Rescue Plan committee; and

WHEREAS, it is necessary to amend the 2022 budget for the American Rescue Plan Fund; and

NOW, THEREFORE, BE IT ORDAINED, by the Caddo Parish Commission in due, legal and regular session convened, that Budget of Estimated Revenues and Expenditures for the American Rescue Plan Fund for the year 2022 be amended as follows:

<u>American Rescue Plan Fund</u>	<u>Budget Increase (Decrease)</u>
Expenditures	
Federal Grant Expenditures	\$30,000

BE IT FURTHER ORDAINED, that if any provision or item of this ordinance or the application thereof is held invalid, such invalidity shall not affect other provisions, items or applications which can be given effect without the invalid provisions, items or applications, and to this end the provisions of this ordinance are hereby declared severable.

BE IT FURTHER ORDAINED, that this ordinance shall take effect upon adoption.

BE IT FURTHER ORDAINED, that all ordinances or parts thereof in conflict herewith are hereby repealed.

**ORDINANCE NO. 6162 OF 2022**

BY THE CADDO PARISH COMMISSION:

AN ORDINANCE AMENDING THE BUDGET OF ESTIMATED REVENUES FOR THE AMERICAN RESCUE PLAN FUND TO PROVIDE AN APPROPRIATION FOR COUNSELING IN PUBLIC HIGH SCHOOLS IN CADDO PARISH AND TO OTHERWISE PROVIDE WITH RESPECT THERETO

WHEREAS, the American Rescue Plan Act of 2021 (ARPA) became law on March 11, 2021; and

WHEREAS, Caddo Parish Commission would like to re-appropriate up to \$100,000 to

provide for counseling at public high schools in Caddo Parish, specifically Southwood High School to impact public safety; and

WHEREAS, this program is provided by SeedLinks Behavior Management; and WHEREAS, Ordinance 6118 of 2021 appropriated \$100,000 for Seedlinks; and WHEREAS, the budget for Seedlinks lapsed at the end of 2021; and

WHEREAS, it is necessary to amend the 2022 budget for the American Rescue Plan Fund; and

NOW, THEREFORE, BE IT ORDAINED, by the Caddo Parish Commission in due, legal and regular session convened, that Budget of Estimated Revenues and Expenditures for the American Rescue Plan Fund for the year 2022 be amended as follows:

<u>American Rescue Plan Fund</u>	<u>Budget Increase (Decrease)</u>
Expenditures	
Federal Grant Expenditures	\$100,000

BE IT FURTHER ORDAINED, that if any provision or item of this ordinance or the application thereof is held invalid, such invalidity shall not affect other provisions, items or applications which can be given effect without the invalid provisions, items or applications, and to this end the provisions of this ordinance are hereby declared severable.

BE IT FURTHER ORDAINED, that this ordinance shall take effect upon adoption.

BE IT FURTHER ORDAINED, that all ordinances or parts thereof in conflict herewith are hereby repealed.

**ORDINANCE NO. 6163 OF 2022**

BY THE CADDO PARISH COMMISSION:

AN ORDINANCE AMENDING THE BUDGET OF ESTIMATED REVENUES FOR THE AMERICAN RESCUE PLAN FUND TO PROVIDE AN APPROPRIATION FOR VOLUNTEERS FOR YOUTH JUSTICE FOR TRUANCY AND TO OTHERWISE PROVIDE WITH RESPECT THERETO

WHEREAS, the Department of Juvenile Services has an ongoing program with the Volunteers for Youth Justice (VYJ) to address concerns related to truant juveniles in Caddo Parish; and

WHEREAS, COVID-19 pandemic has drastically increased truancy issues in Caddo Parish; and

WHEREAS, an appropriation for VYJ was passed with Ordinance 6113 in 2021 but lapsed at the end of the year; and

WHEREAS, the funds will be used to fund truancy expenditures to assist the school system and the Juvenile Services with truancy concerns; and

WHEREAS, the funding is needed to continue to combat the truancy problem in Caddo Parish; and

WHEREAS, this amendment is recommended by the American Rescue Plan committee to re-appropriate the funds; and

WHEREAS, it is necessary to amend the 2022 budget for the American Rescue Plan Fund; and

NOW, THEREFORE, BE IT ORDAINED, by the Caddo Parish Commission in due, legal and regular session convened, that Budget of Estimated Revenues and Expenditures for the American Rescue Plan Fund for the year 2022 be amended as follows:

<u>American Rescue Plan Fund</u>	<u>Budget Increase (Decrease)</u>
Expenditures	
Federal Grant Expenditures	\$150,000

BE IT FURTHER ORDAINED, that if any provision or item of this ordinance or the application thereof is held invalid, such invalidity shall not affect other provisions, items or applications which can be given effect without the invalid provisions, items or applications, and to this end the

provisions of this ordinance are hereby declared severable.

BE IT FURTHER ORDAINED, that this ordinance shall take effect upon adoption.

BE IT FURTHER ORDAINED, that all ordinances or parts thereof in conflict herewith are hereby repealed.

**ORDINANCE NO. 6164 OF 2022**

BY THE CADDO PARISH COMMISSION:

AN ORDINANCE AMENDING THE BUDGET OF ESTIMATED REVENUES FOR THE AMERICAN RESCUE PLAN FUND TO PROVIDE AN APPROPRIATION FOR CADDO PARISH JUVENILE COURT AND TO OTHERWISE PROVIDE WITH RESPECT THERETO

WHEREAS, the American Rescue Plan Act of 2021 (ARPA) became law on March 11, 2021; and

WHEREAS, Caddo Parish Commission would like to re-appropriate up to \$250,000 to provide for revenue replacement of \$90,000 and \$160,000 in additional programming to the Caddo Parish Juvenile Court; and

WHEREAS, the Caddo Parish Juvenile Court has seen an increase in crime due to the COVID-19 pandemic; and

WHEREAS, Ordinance 6112 of 2021 originally appropriated funds for Juvenile Court; and

WHEREAS, the budget lapsed at the end of 2021; and

WHEREAS, the revenue replacement and program funding is needed to continue to reach the youth in our area; and

WHEREAS, this amendment is recommended by the American Rescue Plan committee; and

WHEREAS, it is necessary to amend the 2022 budget for the American Rescue Plan Fund; and

NOW, THEREFORE, BE IT ORDAINED, by the Caddo Parish Commission in due, legal and regular session convened, that Budget of Estimated Revenues and Expenditures for the American Rescue Plan Fund for the year 2022 be amended as follows:

<u>American Rescue Plan Fund</u>	<u>Budget Increase (Decrease)</u>
Expenditures	
Federal Grant Expenditures	\$250,000

BE IT FURTHER ORDAINED, that if any provision or item of this ordinance or the application thereof is held invalid, such invalidity shall not affect other provisions, items or applications which can be given effect without the invalid provisions, items or applications, and to this end the provisions of this ordinance are hereby declared severable.

BE IT FURTHER ORDAINED, that this ordinance shall take effect upon adoption.

BE IT FURTHER ORDAINED, that all ordinances or parts thereof in conflict herewith are hereby repealed.

It was **moved by Mr. Johnson**, seconded by Mrs. Gage-Watts, *that Ordinance No. 6157 of 2022, an ordinance amending the Budget of Estimated Revenues and Expenditures for the Public Works Fund and the Capital Outlay Fund in the amount of \$107,500 to provide an additional appropriation to install welcome signs on I-49 and to otherwise provide with respect thereto* be adopted.

Mr. Johnson said that this is additional funding to install the signs. He said that one sign will be on the north side coming from Arkansas, and the other is on the Desoto side of it.

Mr. Young asked for a rendering of the signs. Dr. Wilson said that he will email it to all of the Commissioners.

At this time, Mr. Johnson's motion carried, as shown by the following roll call votes: AYES: Commissioners Atkins, Burrell, Epperson, Gage-Watts, Jackson, Johnson, Hopkins, Lazarus, Taliaferro, and Young (10). NAYS: Commissioner Chavez (1). ABSENT: Commissioner Jones (1).

ABSTAIN: None (0).

**ORDINANCE NO. 6157 OF 2022**

BY THE CADDO PARISH COMMISSION:

AN ORDINANCE AMENDING THE BUDGET OF ESTIMATED REVENUES AND EXPENDITURES FOR THE PUBLIC WORKS FUND AND THE CAPITAL OUTLAY FUND IN THE AMOUNT OF \$107,500 TO PROVIDE AN ADDITIONAL APPROPRIATION TO INSTALL WELCOME SIGNS ON I-49 AND TO OTHERWISE PROVIDE WITH RESPECT THERETO

WHEREAS, welcome signs add an extra layer of curiosity, or at least charm, for those who pass through these locales; and

WHEREAS, welcome signs can drive economic activity because exciting welcome signs can make a lasting impression that make someone want to visit and spend money in the area; and

WHEREAS, Caddo Parish does not have attractive and friendly welcome signs along I-49 to announce its presence to incoming travelers, tourists, and visitors; and

WHEREAS, attractive welcome signs on I-49 may spur economic development activity; and

WHEREAS, the Caddo Parish Commission adopted Ordinance 5888 in 2019 to appropriate \$50, to design and build welcome signs at the Caddo Parish lines on I-49; and

WHEREAS, the actual cost of the signs will be approximately \$150,000 plus the \$7,500 that was spent on design; and

WHEREAS, the Caddo Parish Commission would like to amend the 2022 budget to appropriate funds to build welcome signs at the Caddo Parish lines on I-49; and

NOW, THEREFORE, BE IT ORDAINED, by the Caddo Parish Commission in due, legal and regular session convened, that Budget of Estimated Revenues and Expenditures for the Public Works Fund and the Capital Outlay Fund for the year 2022 are hereby amended as follows:

	<u>Budget Increase (Decrease)</u>
<u>Public Works Fund</u>	
Other Financing Sources (Uses)	
Transfer to Capital Outlay Fund	\$107,500
Fund Balance	(107,500)
<u>Capital Outlay Fund</u>	
Road & Bridge – I49 Welcome Signs	\$107,500
Other Financing Sources (Uses)	
Transfer from Public Works Fund	\$107,500

BE IT FURTHER ORDAINED, that if any provision or item of this ordinance or the application thereof is held invalid, such invalidity shall not affect other provisions, items or applications which can be given effect without the invalid provisions, items or applications, and to this end the provisions of this ordinance are hereby declared severable.

BE IT FURTHER ORDAINED, that this ordinance shall take effect upon adoption.

BE IT FURTHER ORDAINED, that all ordinances or parts thereof in conflict herewith are hereby repealed.

It was **moved by Mr. Jackson**, seconded by Mr. Hopkins, *that Ordinance No. 6165 of 2022, an ordinance amending the Budget of Estimated Revenues and Expenditures for the E. Edward Jones Housing Trust Fund to provide an appropriation for ERAP housing quality inspections and to otherwise provide with respect thereto* be removed from the agenda.

Mr. Jackson said that those dollars have dried up, and if more dollars come available, he will bring this back before the Commission. Mr. Jackson also mentioned that a person should not have to live in deplorable conditions, no matter their income level.

At this time, Mr. Jackson's motion carried, as shown by the following roll call votes: AYES: Commissioners Atkins, Burrell, Chavez, Epperson, Gage-Watts, Jackson, Johnson, Jones, Lazarus, Taliaferro, and Young (11). NAYS: None (0). ABSENT: Commissioner Hopkins (1). ABSTAIN:

None (0).

It was **moved by Mr. Jackson**, seconded by Mr. Burrell, *that Ordinance No. 6166 of 2022, an ordinance amending the Budget of Estimated Revenues and Expenditures for the E. Edward Jones Housing Trust Fund to roll over an existing 2021 appropriation for eviction mitigation into the 2022 Budget and to otherwise provide with respect thereto* be adopted.

Mr. Jackson asked for a clarification regarding this ordinance. Mrs. Barnett said that is just a process that is rolled forward for funds that have not been used. Mr. Jackson reiterated that these are not new dollars.

Mrs. Gage-Watts wanted to know if people have to be unemployed to participate in this program. Mrs. Barnett said that this is for people, employed or unemployed, who need assistance for rent.

At this time, Mr. Jackson's motion carried, as shown by the following roll call votes: AYES: Commissioners Atkins, Burrell, Chavez, Epperson, Gage-Watts, Hopkins, Jackson, Johnson, Jones, Lazarus, Taliaferro, and Young (12). NAYS: None (0). ABSENT: None (0). ABSTAIN: None (0).

#### **ORDINANCE NO. 6166 OF 2022**

BY THE CADDO PARISH COMMISSION:

AN ORDINANCE AMENDING THE BUDGET OF ESTIMATED REVENUES AND EXPENDITURES FOR THE E. EDWARD JONES HOUSING TRUST FUND TO ROLL OVER AN EXISTING 2021 APPROPRIATION FOR EVICTION MITIGATION INTO THE 2022 BUDGET AND TO OTHERWISE PROVIDE WITH RESPECT THERETO

WHEREAS, the federal moratorium on evictions of qualified tenants by landlords has expired as of August 26, 2021; and

WHEREAS, the ongoing economic downturn due to the COVID-19 pandemic continues to adversely impact both state and local economies; and

WHEREAS, many of our citizens continue to experience financial hardships and are unable to pay rent and facing eviction as a result; and

WHEREAS, eviction of large numbers of our citizens will cause both a social and economic crisis in the area; and

WHEREAS, the Emergency Rental Assistance Program (ERAP) made funds available to assist qualifying households pay rent and avoid eviction; and

WHEREAS, some qualifying renters may still be subject to eviction while they wait for their rental assistance applications to be completed and approved before funds are disbursed; and

WHEREAS, Ordinance 6091 of 2021 appropriated \$20,000 for emergency eviction mitigation; and

WHEREAS, the budget for eviction mitigation lapsed at the end of 2021; and WHEREAS, the funds that were set aside in 2021 for legal services related to eviction mitigation remained mostly unused and Caddo Parish Commission would like to re-appropriate the remaining \$19,350 for 2022; and

WHEREAS, a portion of funds allocated in 2022 would be made available to advertise the availability of legal services related to eviction mitigation; and

WHEREAS, the proposed emergency eviction mitigation program continues to be intended to help bridge the gap between the rental assistance application and funding to help prevent qualifying applicants from being evicted; and

WHEREAS, funds for this program would be reimbursed from the state portion of Caddo Parish rental assistance funds; and

NOW, THEREFORE, BE IT ORDAINED, by the Caddo Parish Commission in due, legal and regular session convened, that the Budget of Estimated Revenues and Expenditures for the E. Edward Jones Housing Trust Fund for the year 2022 is hereby amended as follows:

	<u>Budget Increase (Decrease)</u>
<u>E. Edward Jones Trust Fund</u>	
Eviction Mitigation Program	\$19,350
Fund Balance	(\$19,350)

BE IT FURTHER ORDAINED, that if any provision or item of this ordinance or the application thereof is held invalid, such invalidity shall not affect other provisions, items or applications which can be given effect without the invalid provisions, items or applications, and to this end the provisions of this ordinance are hereby declared severable.

BE IT FURTHER ORDAINED, that this ordinance shall take effect upon adoption.

BE IT FURTHER ORDAINED, that all ordinances or parts thereof in conflict herewith are hereby repealed.

It was **moved by Mr. Hopkins**, seconded by Mr. Young, *that Ordinance No. 6167 of 2022, an ordinance repealing Section 38-4 of the Code of Ordinances regarding the Shreveport-Caddo 2030 Master Plan and otherwise providing with respect thereto* be adopted.

Mr. Hopkins explained that this ordinance would repeal the Master Plan. He believes that this legislation would take the zoning back to a more rural/agriculture aspect of it. Mr. Hopkins also said that a comprehensive plan is still needed to better fit the Parish and its citizens.

Mr. Johnson wanted to know if this was to repeal the UDC or the Master Plan. Mr. Hopkins said that this is to repeal the Master. Mr. Johnson suggested that the Master Plan could be amended and repeal the UDC.

**Substitute motion by Mr. Burrell**, seconded by Mr. Johnson, *that Ordinance No. 6167 of 2022 be remanded to the Long-Range Planning Committee.*

Mr. Jackson pointed out that this came out of the Long-Range Planning Committee. Mr. Young agreed. Mr. Burrell wanted to know the result that came out of Committee. Mr. Atkins said that this legislation came out of the Long-Range Planning. Mr. Chavez agreed and said that the Citizens Advisory Committee wanted to abolish the UDC and the Master Plan.

Mr. Burrell withdrew his substitute motion.

At this time, Mr. Hopkins' motion failed, as shown by the following roll call votes: AYES: Commissioners Atkins, Chavez, Hopkins, Lazarus, Taliaferro, and Young (6). NAYS: Commissioners Burrell, Epperson, Gage-Watts, Jackson, Johnson, and Jones (6). ABSENT: None (0). ABSTAIN: None (0).

It was **moved by Mr. Young**, seconded by Mr. Burrell, *that Ordinance No. 6168 of 2022, an ordinance repealing Ordinance 6071 of 2021 relative to establishment of a Parish Planning Commission and otherwise providing with respect thereto* be postponed to the Regular Session following the receipt of the Attorney General's opinion. Motion carried, as shown by the following roll call votes: AYES: Commissioners Atkins, Burrell, Chavez, Epperson, Jackson, Johnson, Jones, Lazarus, Taliaferro, and Young (10). NAYS: Commissioners Gage-Watts and Hopkins (2). ABSENT: None (0). ABSTAIN: None (0).

It was **moved by Mr. Johnson**, seconded by Mr. Jones, *that Ordinance No. 6170 of 2022, an ordinance amending the Budget of Estimated Revenues and Expenditures for the Oil and Gas Fund for the year 2022 to provide an appropriation for relocation assistance and to otherwise provide with respect thereto* be adopted.

Mr. Johnson said that the ERAP money has "dried up" and evictions are becoming more frequent. He said that these funds could be used to help relocate those citizens to another place to live.

Mr. Jones gave the following comment:

I was brought up brought up earlier about these people and them paying their rent and all this good stuff. I want to make it abundantly clear that many of the citizens who live in my district who are having to deal with this type of situation, those who are asking to relocate are not responsible for the mold that's been in that building for years. Particular units within my community—Woodlawn Terrace, it's no secret there have been in pretty bad condition since I was a small child. It's hard to blame people here in 2022 for things that have not been corrected over the years. I can understand, although Commissioner Jackson pulled his resolution, it's best for us to make sure that we're spending our tax dollars in places where things are going to get done, and we're not putting people in a position where they have a low quality of life. I would hope that we would be concerned with the quality of life for all citizens in Caddo Parish. Commissioner Jackson asked the question earlier that Jesus asked, 'who is my neighbor?' The person who shined most in that story was the one who showed mercy, and it was an amazing story. He was so against a Samaritan that he could not even say a Samaritan was right. But all he could say was the one that showed mercy. And Jesus said go and do likewise. At what point are we going to do likewise? And what point are we going to be just as concerned with what's going on in Cedar Grove, Hollywood, and other places as we are in Blanchard, in

Keithville, and in Greenwood? Because when I stood before this commission for an appointment, that's what I said, is that I would be just as concerned about what goes on in the inner city as I would in the rural areas. I don't want any one of us to assume that anyone sits on this board plays politics, because me, personally speaking for myself, I want to make sure I do what makes sense for everybody, and it does not make sense for us to be okay with the quality of life in the rural area but not ok with how people are living in the inner city. I get a lot of emails about the zoning board. But I hope everybody's just concerned about the mothers that I have to here, who are struggling to keep their children healthy because they live in mold. Woodlawn Terrace is not subsidized housing. I need to make that abundantly clear here today—that the people who live in my district are not living for free. They have to pay their rent, they have to be gainfully employed, and COVID-19 happened to everybody in this room. Whether you were willing to do whether you were poor, we all felt the effects of it in some shape, form or fashion. And I'm just beyond the pettiness that I hear because we all want our way. What I would like to see begin to happen within not just this board, but in humanity is that we actually care and start living the gospel that some of us like we believe in. Because if we care, and we're merciful, like we stand up on Sunday mornings and act like we are, then that should be evident Monday through Saturday as well. Not just when you get in front of your other parishioners or pastors, but you should live that out because that's what true character is. It's who you are when nobody's looking, and I'm just beyond the pettiness and foolishness of not getting things done because we want to make sure okay, we're getting our way, this is an issue that needs to be addressed. People need to live somewhere where it's clean. And if we care about the children that we say are our future, they need to be able to go to school every day, knowing that they're going to come home to a clean house, at least livable. Now, I can't make people clean their homes up. I can't do that. But not everybody who's in this situation is keeping the dirty house. Let's be honest with ourselves. Some of these people are living in situations far beyond their control in according to the lease agreements that they have the landlords are responsible for the repairs. And if they're not making the repairs, and they're not holding up the end of the lease. The least we can do is put people in the position where they can live comfortably. I don't think that's asking too much. So, I want to start carrying the same enthusiasm. And please understand the passion of my heart. I don't say a whole lot, I guess because I'm the new guy. We've got to start using common sense and making sure that we use that we are with this zoning case with what's going in the inner city. So when we start talking about crime prevention, I want to see this same place packed out because according to what I heard today, that's what we need to be focusing on, not the rural areas. So, the next time we talk about crime prevention from the Caddo Parish Commission standpoint, please come back and speak up. Please be in here. The moment we got ready to talk about inner city issues, the Chamber got empty. Everybody ran out of here. The moment we talked about who was my neighbor—nobody has anything to say. I want every citizen to be heard. I want every citizen to have to be able to exercise their rights. But I find it shameful that we will clear the Chambers when it's time to talk about other things that are affecting Caddo Parish, but you want me to be concerned with all of Caddo Parish, but you don't have to. That's not right. We need to grow up from that.

Mr. Jackson agreed with Mr. Jones. He said that one of the citizens came down here and said, 'Nobody wants to live in that sewer dump.' Mr. Jackson said that he was referring to Shreveport, and "so goes the City of Shreveport, so goes the Parish of Caddo". Mr. Jackson said that people should live in livable conditions. He asked that the Commissioners adopt this ordinance.

Mr. Taliaferro wanted to know if there was an opportunity to recoup the money from the people who are in direct violation. Attorney Bernstein said that there was not.

Mr. Johnson pointed out that this ordinance is parish-wide, not just for the City of Shreveport. He said that this is to help anyone who is eligible to relocate.

Mr. Chavez wanted to know if there was a pre-inspection requirement of a future facility. He asked that this be included in the CEA.

At this time, Mr. Johnson's motion carried, as shown by the following roll call votes: AYES: Commissioners Atkins, Burrell, Chavez, Epperson, Gage-Watts, Hopkins, Jackson, Johnson, Jones, Lazarus, Taliaferro, and Young (12). NAYS: None (0). ABSENT: None (0). ABSTAIN: None (0).

#### **ORDINANCE NO. 6170 OF 2022**

BY THE CADDO PARISH COMMISSION:

AN ORDINANCE AMENDING THE BUDGET OF ESTIMATED REVENUES AND EXPENDITURES FOR THE OIL AND GAS FUND FOR THE YEAR 2022 TO PROVIDE AN APPROPRIATION FOR RELOCATION ASSISTANCE AND TO OTHERWISE PROVIDE WITH

RESPECT THERETO

WHEREAS, many citizens in Caddo Parish require relocation assistance due to substandard housing conditions, homelessness, or to escape a domestic violence situation; and

WHEREAS, many citizens are unable to pay the costs associated with relocating to a new home causing them to remain in unsustainable living conditions; and

WHEREAS, citizens requiring relocation assistance, need help with security deposits, first month rent, and/or moving expenses; and

WHEREAS, the Caddo Parish Commission would like to appropriate up to \$72,000 to help citizens relocate to a new living arrangement due to unsafe and/or unsanitary living conditions, homelessness, to leave a domestic violence situation, or other verifiable reason for needing relocation assistance; and

WHEREAS, the relocation assistance would be limited to a maximum of \$1,200 per family; and

WHEREAS, households receiving assistance must have a current monthly gross income or 2021 annual gross income of no more than 80% of the area median income; and

WHEREAS, the relocation funds cannot duplicate funding already received from another funding source; and

WHEREAS, Caddo Parish would contract with Hope Connections and the Providence House to assist with the relocation assistance, given these agencies are experienced in assisting persons with relocation needs; and

NOW, THEREFORE, BE IT ORDAINED, by the Caddo Parish Commission in due, legal and regular session convened, that the Budget of Estimated Revenues and Expenditures for the Oil and Gas Fund for the year 2022 is hereby amended as follows:

	<u>Budget Increase (Decrease)</u>
<u>Oil and Gas Fund Relocation Assistance</u>	
Providence House	\$ 36,000
Hope Connections	\$ 36,000
Fund Balance	(\$ 72,000)

BE IT FURTHER ORDAINED, that if any provision or item of this ordinance or the application thereof is held invalid, such invalidity shall not affect other provisions, items or applications which can be given effect without the invalid provisions, items or applications, and to this end the provisions of this ordinance are hereby declared severable.

BE IT FURTHER ORDAINED, that this ordinance shall take effect upon adoption.

BE IT FURTHER ORDAINED, that all ordinances or parts thereof in conflict herewith are hereby repealed.

It was **moved by Mr. Johnson**, seconded by Mr. Chavez, *that Ordinance No. 6171 of 2022, an ordinance amending the 2022 Budget of Estimated Revenues and Expenditures for the American Rescue Plan Fund to provide an additional appropriation for Fit for Life Ministries and to otherwise provide with respect thereto* be adopted.

Mr. Johnson said that there was lost revenue due to the pandemic. He said that this is for that loss.

At this time, Mr. Johnson's motion carried, as shown by the following roll call votes: AYES: Commissioners Atkins, Burrell, Epperson, Gage-Watts, Hopkins, Jackson, Johnson, Jones, Lazarus, Taliaferro, and Young (11). NAYS: None (0). ABSENT: Commissioner Chavez (1). ABSTAIN: None (0).

**ORDINANCE NO. 6171 OF 2022**

BY THE CADDO PARISH COMMISSION:

AN ORDINANCE AMENDING THE 2022 BUDGET OF ESTIMATED REVENUES AND EXPENDITURES FOR THE AMERICAN RESUCE PLAN FUND TO PROVIDE AN ADDITIONAL APPROPRIATION FOR FIT FOR LIFE MINISTRIES AND TO OTHERWISE PROVIDE WITH RESPECT THERETO

WHEREAS, the American Rescue Plan Act of 2021 (ARPA) became law on March 11, 2021; and

WHEREAS, the ARPA provided \$350 billion in additional funding for state and local governments; and

WHEREAS, the Caddo Parish Commission approved over \$22 million in ARPA expenditures within Caddo Parish, including monies to fund sporting events that would boost economic development within the Parish; and

WHEREAS, the Caddo Parish Commission appropriated \$30,000 in its 2022 budget for Fit for Life Ministries; and

WHEREAS, the Caddo Parish Commission would like to amend the 2022 American Rescue Plan Fund budget to provide an additional appropriation of \$35,000 for Fit for Life; and

NOW, THEREFORE, BE IT ORDAINED, by the Caddo Parish Commission in due, legal and regular session convened, that Budget of Estimated Revenues and Expenditures for the Economic Development Fund for the year 2022 is hereby amended as follows:

	<u>Budget Increase (Decrease)</u>
<u>American Rescue Plan Fund</u>	
Grant Programs – Other	
Fit for Life	\$35,000
Fund Balance	(\$35,000)

BE IT FURTHER ORDAINED, that if any provision or item of this ordinance or the application thereof is held invalid, such invalidity shall not affect other provisions, items or applications which can be given effect without the invalid provisions, items or applications, and to this end the provisions of this ordinance are hereby declared severable.

BE IT FURTHER ORDAINED, that this ordinance shall take effect upon adoption.

BE IT FURTHER ORDAINED, that all ordinances or parts thereof in conflict herewith are hereby repealed.

It was **moved by Mr. Jackson**, seconded by Mr. Burrell, *that Ordinance No. 6172 of 2022, an ordinance amending the 2022 Budget of Estimated Revenues and Expenditures for the E. Edward Jones Housing Trust Fund to provide appropriations for housing projects and to otherwise provide with respect thereto* be adopted.

Mr. Jackson said that he would like to add the National Development Council process to the ordinance.

Mr. Young wanted to know the level of funding that is currently in the E. Edward Jones Trust Fund. Mrs. Barnett said there is about \$2M in the fund.

Mr. Atkins wanted to know what the National Development Council. Mr. Jackson said that this is the entity that has been formally contracted to manage the Housing Trust Fund.

At this time, Mr. Jackson's motion carried, as shown by the following roll call votes: AYES: Commissioners Burrell, Chavez, Epperson, Gage-Watts, Hopkins, Jackson, Johnson, Jones, Lazarus, Taliaferro, and Young (11). NAYS: Commissioner Atkins (1). ABSENT: None (0). ABSTAIN: None (0).

#### **ORDINANCE NO. 6172 OF 2022**

BY THE CADDO PARISH COMMISSION:

AN ORDINANCE AMENDING THE 2022 BUDGET OF ESTIMATED REVENUES AND EXPENDITURES FOR THE E. EDWARD JONES HOUSING TRUST FUND TO PROVIDE APPROPRIATIONS FOR HOUSING PROJECTS AND TO OTHERWISE PROVIDE WITH RESPECT THERETO

WHEREAS, the Caddo Parish Commission appropriated \$2,000,000 for housing projects in the 2022 budget for the E. Edward Jones Housing Trust Fund (EEJHTF); and

WHEREAS, the Caddo Parish Commission would like to amend the 2022 EEJHTF budget to provide an appropriation of \$600,000 each for the Northwest Louisiana Community Development Corporation (NWLACDC), Grace Project, and Image Changers for housing projects; and

WHEREAS, NWLA CDC has a proven record of meeting the needs of low to moderate income individuals and families in underserved communities and funds will be used to rehabilitate ten (10) residential rental units and will cover administrative costs, developer fees, property insurance, and architectural fees; and

WHEREAS, Grace Project intends to establish a program that would identify and rehabilitate 50 dilapidated, adjudicated, and abandoned properties to prepare them for sale to prospective homeowners; and

WHEREAS, Image Changers was founded with the specific objective of assisting low to moderate income families with economic development by promoting and supporting quality education, affordable home ownership, community development, and enhanced social services; and

WHEREAS, the Caddo Parish Commission would like to amend the 2022 E. Edward Jones Housing Trust Fund Budget to provide an appropriation of \$1,800,000 for to provide \$600,000 each for NWLA CDC, Grace Project, Image Changers; and

NOW, THEREFORE, BE IT ORDAINED, by the Caddo Parish Commission in due, legal and regular session convened, that Budget of Estimated Revenues and Expenditures for the E. Edward Jones Housing Trust Fund for the year 2022 is hereby amended as follows:

	<u>Budget Increase (Decrease)</u>
<u>E. Edward Jones Trust Fund</u>	
Grant Program—Other	
Grace Project	\$600,000
NWLA CDC	\$600,000
Image Changers	\$600,000
Fund Balance	(\$1,800,000)

BE IT FURTHER ORDAINED, that if any provision or item of this ordinance or the application thereof is held invalid, such invalidity shall not affect other provisions, items or applications which can be given effect without the invalid provisions, items or applications, and to this end the provisions of this ordinance are hereby declared severable.

BE IT FURTHER ORDAINED, that this ordinance shall take effect upon adoption.

BE IT FURTHER ORDAINED, that all ordinances or parts thereof in conflict herewith are hereby repealed.

It was **moved by Mrs. Gage-Watts**, seconded by Mr. Burrell, *that Ordinance No. 6173 of 2022, be amended to reduce the appropriation to \$3,500 and adopted.*

Mrs. Gage-Watts said that this group will provide a five-week summer camp concentrating on the performing arts.

**Substitute motion by Mr. Jackson**, seconded by Mr. Lazarus, *to englobe and adopt the following ordinances:*

- *Ordinance No. 6173 of 2022, an ordinance amending the 2022 Budget of Estimated Revenues and Expenditures for the Riverboat Fund and the Oil and Gas Fund to provide an additional appropriation for Urban Support and to otherwise provide with respect thereto as amended*
- *Ordinance No. 6174 of 2022, an ordinance amending the 2021 Budget to amend the Budget of Estimated Revenues and Expenditures for the Head Start Fund and to otherwise provide with respect thereto*
- *Ordinance No. 6175 of 2022, an ordinance amending the 2021 Budget to amend the Budget of Estimated Revenues and Expenditures for the Section 8 Fund and to otherwise provide with respect thereto*
- *Ordinance No. 6176 of 2022, an ordinance amending the Budget of estimated Revenues and Expenditures for the General Fund to provide an appropriation for Wheel Chair Ramp and Roof Repair Program and to otherwise provide with respect thereto*
- *Ordinance No. 6177 of 2022, an ordinance amending the Budget of Estimated Revenues and Expenditures for the Oil and Gas Fund and the Riverboat Fund to provide an appropriation of \$32,000 for a Mural Program and to otherwise provide with respect thereto*

- *Ordinance No. 6186 of 2022, an ordinance amending the Budget of Estimated Revenues and Expenditures for the E Edward Jones Housing Trust Fund for the year 2022 to appropriate funds received from the US Treasury in the amount of \$5,274,675 for the Emergency Rental Assistance Program and to otherwise provide with respect thereto*
- *Ordinance No. 6187 of 2022, an ordinance amending the Budget of Estimated Revenues and Expenditures for the E Edward Jones Housing Trust Fund for the year 2021 to appropriate Emergency Rental Assistance Program from the State of Louisiana and to otherwise provide with respect thereto*
- *Ordinance No. 6188 of 2022, an ordinance amending the Budget of Estimated Revenues for the American Rescue Plan Fund to provide an appropriation for Ring Doorbell Pilot Program in Caddo Parish and to otherwise provide with respect thereto*

At this time, Mr. Jackson's substitute motion carried, as shown by the following roll call votes: AYES: Commissioners Atkins, Burrell, Chavez, Epperson, Gage-Watts, Hopkins, Jackson, Johnson, Jones, Lazarus, and Young (11). NAYS: None (0). ABSENT: Commissioner Taliaferro (1). ABSTAIN: None (0).

**ORDINANCE NO. 6173 OF 2022**

BY THE CADDO PARISH COMMISSION:

AN ORDINANCE AMENDING THE 2022 BUDGET OF ESTIMATED REVENUES AND EXPENDITURES FOR THE RIVERBOAT FUND AND THE OIL AND GAS FUND TO PROVIDE AN ADDITIONAL APPROPRIATION FOR URBAN SUPPORT AND TO OTHERWISE PROVIDE WITH RESPECT THERETO

WHEREAS, the Caddo Parish Commission appropriated \$5,000 for Urban Support in its 2022 budget for the Riverboat Fund to provide community mentoring, social adaptation, etiquette training, educational tutoring, and career choice activities; and

WHEREAS, the Urban Support Agency, Inc. was started in 1996 by a group of retired educators and community leaders with a vision for empowering the youth of our area to become successful citizens; and

WHEREAS, Urban Support previously received an appropriation of \$15,000 in the 2021 budget; and

WHEREAS, Urban Support requires an additional \$8,000 to adequately support its 2022 program initiatives; and

NOW, THEREFORE, BE IT ORDAINED, by the Caddo Parish Commission in due, legal and regular session convened, that Budget of Estimated Revenues and Expenditures for the Riverboat Fund and the Oil and Gas Fund for the year 2022 are hereby amended as follows:

	<u>Budget Increase (Decrease)</u>
<u>Riverboat Fund</u>	
Allocation to Other Entities	
Urban Support	\$8,000
<u>Oil and Gas Fund</u>	
Transfer to Other Funds	\$8,000
Fund Balance	(\$8,000)

BE IT FURTHER ORDAINED, that if any provision or item of this ordinance or the application thereof is held invalid, such invalidity shall not affect other provisions, items or applications which can be given effect without the invalid provisions, items or applications, and to this end the provisions of this ordinance are hereby declared severable.

BE IT FURTHER ORDAINED, that this ordinance shall take effect upon adoption.

BE IT FURTHER ORDAINED, that all ordinances or parts thereof in conflict herewith are hereby repealed.

**ORDINANCE NO. 6174 OF 2022**

BY THE CADDO PARISH COMMISSION:

AN ORDINANCE AMENDING THE 2021 BUDGET TO AMEND THE BUDGET OF ESTIMATED REVENUES AND EXPENDITURES FOR THE HEAD START FUND AND TO OTHERWISE PROVIDE WITH RESPECT THERETO

WHEREAS, Head Start programs promote the school readiness of infants, toddlers, and preschool-aged children from low-income families; and

WHEREAS, the Head Start program is funded through a federal grant from the United States Department of Health and Human Services (HHS); and

WHEREAS, the Head Start program received two additional awards from HHS for COVID19 and from the American Rescue Plan; and

WHEREAS, it is necessary to amend the budget for revenues and expenditures for the Head Start Fund to appropriate these funds; and

NOW, THEREFORE, BE IT ORDAINED, by the Caddo Parish Commission in due, legal and regular session convened, that Budget of Estimated Revenues and Expenditures for the Head Start Fund for the year 2021 as follows:

	<u>Budget Increase (Decrease)</u>
<u>Head Start Fund</u>	
Revenue	
Head Start Grant	\$2,220,000
Head Start Program	\$2,220,000

BE IT FURTHER ORDAINED, that if any provision or item of this ordinance or the application thereof is held invalid, such invalidity shall not affect other provisions, items or applications which can be given effect without the invalid provisions, items or applications, and to this end the provisions of this ordinance are hereby declared severable.

BE IT FURTHER ORDAINED, that this ordinance shall take effect upon adoption.

BE IT FURTHER ORDAINED, that all ordinances or parts thereof in conflict herewith are hereby repealed.

**ORDINANCE NO. 6175 OF 2022**

BY THE CADDO PARISH COMMISSION:

AN ORDINANCE AMENDING THE 2021 BUDGET TO AMEND THE BUDGET OF ESTIMATED REVENUES AND EXPENDITURES FOR THE SECTION 8 FUND AND TO OTHERWISE PROVIDE WITH RESPECT THERETO

WHEREAS, the Parish of Caddo has been the recipient of the Section 8 grant from the Department of Housing and Urban Development (HUD) since the 1970s; and

WHEREAS, Section 8 is a housing choice voucher program that the federal program has for assisting very low-income families, the elderly, and the disabled to afford decent, safe, and sanitary housing in the private market; and

WHEREAS, the Section 8 program received more federal dollars in 2021 due to the performance of the program in 2020; and

WHEREAS, it is necessary to amend a budget for revenues and expenditures for the Section 8 Housing Fund; and

NOW, THEREFORE, BE IT ORDAINED, by the Caddo Parish Commission in due, legal and regular session convened, that Budget of Estimated Revenues and Expenditures for the Section 8 Fund for the year 2021 as follows:

	<u>Budget Increase (Decrease)</u>
<u>Section 8 Housing Fund</u>	
Revenue	
Section 8 Grant	\$200,000
Section 8 Grant Expenses	\$200,000

BE IT FURTHER ORDAINED, that if any provision or item of this ordinance or the

application thereof is held invalid, such invalidity shall not affect other provisions, items or applications which can be given effect without the invalid provisions, items or applications, and to this end the provisions of this ordinance are hereby declared severable.

BE IT FURTHER ORDAINED, that this ordinance shall take effect upon adoption.

BE IT FURTHER ORDAINED, that all ordinances or parts thereof in conflict herewith are hereby repealed.

**ORDINANCE NO. 6176 OF 2022**

BY THE CADDO PARISH COMMISSION:

AN ORDINANCE AMENDING THE BUDGET OF ESTIMATED REVENUES AND EXPENDITURES FOR THE GENERAL FUND TO PROVIDE AN APPROPRIATION FOR WHEEL CHAIR RAMP AND ROOF REPAIR PROGRAM AND TO OTHERWISE PROVIDE WITH RESPECT THERETO

WHEREAS, the Parish of Caddo receives revenue from the Capital Area Finance Authority (CAFA) from application fees related to home mortgage loans; and

WHEREAS, the Caddo Parish Commission would like to use these funds to establish a Wheel Chair Ramp and Roof Repair Program; and

WHEREAS, the Wheel Chair Ramp and Roof Repair Program will help seniors, veterans and disabled residents; and

WHEREAS, seniors, veterans and disabled residents are an important part of our community; and

WHEREAS, these residents are often on a fixed income and unable to perform such task;

WHEREAS, helping with minor repairs will help keeps these individuals safely housed; and

WHEREAS, the Parish of Caddo will contract with an established community or faith-based organization to provide services; and

WHEREAS it is necessary to amend the 2022 General Fund Budget to provide an appropriation of \$56,000 for the Wheel Chair Ramp and Roof Repair Program; and

NOW, THEREFORE, BE IT ORDAINED, by the Caddo Parish Commission in due, legal and regular session convened, that Budget of Estimated Revenues and Expenditures for the Riverboat Fund for the year 2022 is hereby amended as follows:

<u>General Fund</u>	<u>Budget Increase (Decrease)</u>
NGO Appropriations	
Wheel Chair Ramp and Roof Repair Program	\$56,000
Fund Balance	(\$56,000)

BE IT FURTHER ORDAINED, that if any provision or item of this ordinance or the application thereof is held invalid, such invalidity shall not affect other provisions, items or applications which can be given effect without the invalid provisions, items or applications, and to this end the provisions of this ordinance are hereby declared severable.

BE IT FURTHER ORDAINED, that this ordinance shall take effect upon adoption.

BE IT FURTHER ORDAINED, that all ordinances or parts thereof in conflict herewith are hereby repealed.

**ORDINANCE NO. 6177 OF 2022**

BY THE CADDO PARISH COMMISSION:

AN ORDINANCE AMENDING THE BUDGET OF ESTIMATED REVENUES AND EXPENDITURES FOR THE OIL AND GAS FUND AND THE RIVERBOAT FUND TO PROVIDE AN APPROPRIATION OF \$32,000 FOR A MURAL PROGRAM AND TO OTHERWISE PROVIDE WITH RESPECT THERETO

WHEREAS, Shreveport Regional Art Council (SRAC) and Poetic X, the Caddo Parish Poet Laureate, would like to place murals across public buildings throughout the Parish; and

WHEREAS, each installation would include a Poem written by Poetic X and illustrated by a local Artist; and

WHEREAS, the Poetry would serve to inspire residents and visitors to each site – and create “selfie stations” throughout the Parish; and

WHEREAS, the total project would be \$96,000 over three years; and

WHEREAS it is necessary to amend the 2022 Oil and Gas Fund and Riverboat budgets to provide an appropriation of \$32,000 to SRAC for the mural program; and

NOW, THEREFORE, BE IT ORDAINED, by the Caddo Parish Commission in due, legal and regular session convened, that Budget of Estimated Revenues and Expenditures for the Oil and Gas Fund for the year 2022 is hereby amended as follows:

	<u>Budget Increase (Decrease)</u>
<u>Oil and Gas Fund</u>	
Transfer to Riverboat Fund	\$32,000
Fund Balance	(\$32,000)
 <u>Riverboat Fund</u>	
SRAC Mural Program	\$32,000
Transfer from Oil and Gas	\$32,000

BE IT FURTHER ORDAINED, that if any provision or item of this ordinance or the application thereof is held invalid, such invalidity shall not affect other provisions, items or applications which can be given effect without the invalid provisions, items or applications, and to this end the provisions of this ordinance are hereby declared severable.

BE IT FURTHER ORDAINED, that this ordinance shall take effect upon adoption.

BE IT FURTHER ORDAINED, that all ordinances or parts thereof in conflict herewith are hereby repealed.

**ORDINANCE NO. 6186 OF 2022**

BY CADDO PARISH COMMISSION:

AN ORDINANCE AMENDING THE BUDGET OF ESTIMATED REVENUES AND EXPENDITURES FOR THE E EDWARD JONES HOUSING TRUST FUND FOR THE YEAR 2022 TO APPROPRIATE FUNDS RECEIVED FROM THE US TREASURY IN THE AMOUNT OF \$5,274,675 FOR THE EMERGENCY RENTAL ASSISTANCE PROGRAM AND TO OTHERWISE PROVIDE WITH RESPECT THERETO

WHEREAS, the Emergency Rental Assistance Program (ERAP) made available \$25 billion to assist households that are unable to pay rent and utilities due to the COVID-19 pandemic; and

WHEREAS, the Parish of Caddo distributed over \$32 million in 2021 of ERAP from the US Treasury and the State of Louisiana; and

WHEREAS, the Parish of Caddo has been reallocated ERAP funds from the State reallocation of \$4,423,024.15 and from the National reallocation of \$851,650.20; and

WHEREAS, it is necessary to amend the 2022 Budget in order to appropriate said grant proceeds.

NOW, THEREFORE, BE IT ORDAINED, by the Caddo Parish Commission in due, legal and regular session convened, that the Budget of Estimated Revenues and Expenditures for the E Edward Jones Housing Trust Fund for the year 2022 is hereby amended as follows:

	<u>Budget Increase (Decrease)</u>
<u>E Edward Jones Housing Trust Fund</u>	
Revenues	
Federal Grant	\$5,274,675
Expenditures	
Grant Programs	\$5,274,675

BE IT FURTHER ORDAINED, that if any provision or item of this ordinance or the application thereof is held invalid, such invalidity shall not affect other provisions, items or applications, which can be given effect without the invalid provisions, items or applications, and to this end the provisions of this ordinance are hereby declared severable.

BE IT FURTHER ORDAINED, that this ordinance shall take effect upon adoption.

BE IT FURTHER ORDAINED, that all ordinances or parts thereof in conflict herewith are hereby repealed.

**ORDINANCE NO. 6187 OF 2022**

BY CADDO PARISH COMMISSION:

AN ORDINANCE AMENDING THE BUDGET OF ESTIMATED REVENUES AND EXPENDITURES FOR THE E EDWARD JONES HOUSING TRUST FUND FOR THE YEAR 2021 TO APPROPRIATE EMERGENCY RENTAL ASSISTANCE PROGRAM FROM THE STATE OF LOUISIANA AND TO OTHERWISE PROVIDE WITH RESPECT THERETO

WHEREAS, the Emergency Rental Assistance Program (ERAP) made available \$25 billion to assist households that are unable to pay rent and utilities due to the COVID-19 pandemic; and

WHEREAS, the State of Louisiana received ERAP funds from the US Treasury for the benefit of Parish of Caddo residents;

WHEREAS, the Parish of Caddo administered the funds in 2021 on behalf of the State; and

WHEREAS, it is necessary to amend the 2021 Budget in order to appropriate said grant proceeds.

NOW, THEREFORE, BE IT ORDAINED, by the Caddo Parish Commission in due, legal and regular session convened, that the Budget of Estimated Revenues and Expenditures for the E Edward Jones Housing Trust Fund for the year 2021 is hereby amended as follows:

	<u>Budget Increase (Decrease)</u>
<u>E Edward Jones Housing Trust Fund</u>	
Revenues	
Federal Grant	\$17,926,511
Expenditures	
Grant Programs	\$17,926,511

BE IT FURTHER ORDAINED, that if any provision or item of this ordinance or the application thereof is held invalid, such invalidity shall not affect other provisions, items or applications, which can be given effect without the invalid provisions, items or applications, and to this end the provisions of this ordinance are hereby declared severable.

BE IT FURTHER ORDAINED, that this ordinance shall take effect upon adoption.

BE IT FURTHER ORDAINED, that all ordinances or parts thereof in conflict herewith are hereby repealed.

**ORDINANCE NO. 6188 OF 2022**

BY THE CADDO PARISH COMMISSION:

AN ORDINANCE AMENDING THE BUDGET OF ESTIMATED REVENUES FOR THE AMERICAN RESCUE PLAN FUND TO PROVIDE AN APPROPRIATION FOR RING DOORBELL PILOT PROGRAM IN CADDO PARISH AND TO OTHERWISE PROVIDE WITH RESPECT THERETO

WHEREAS, the American Rescue Plan Act of 2021 (ARPA) became law on March 11, 2021; and

WHEREAS, Caddo Parish Commission would like to appropriate up to \$100,000 to provide ring doorbell security for high crime areas; and

WHEREAS, this program would provide citizens and law enforcement with an additional tool to help deter crime; and

WHEREAS, citizens in specified and targeted districts can receive the device and one year of service at no cost to the citizen; and

WHEREAS, the device will allow law enforcement access and register with the Shreveport Crime Center; and

WHEREAS, it is necessary to amend the 2022 budget for the American Rescue Plan Fund; and

NOW, THEREFORE, BE IT ORDAINED, by the Caddo Parish Commission in due, legal and regular session convened, that Budget of Estimated Revenues and Expenditures for the American Rescue Plan Fund for the year 2022 be amended as follows:

	<u>Budget Increase (Decrease)</u>
<u>American Rescue Plan Fund</u>	
Expenditures	
Federal Grant Expenditures	\$100,000

BE IT FURTHER ORDAINED, that if any provision or item of this ordinance or the application thereof is held invalid, such invalidity shall not affect other provisions, items or applications which can be given effect without the invalid provisions, items or applications, and to this end the provisions of this ordinance are hereby declared severable.

BE IT FURTHER ORDAINED, that this ordinance shall take effect upon adoption.

BE IT FURTHER ORDAINED, that all ordinances or parts thereof in conflict herewith are hereby repealed.

It was **moved by Mr. Epperson**, seconded by Mrs. Gage-Watts, *that Ordinance No. 6189 of 2022, an ordinance to enact Section 2-5 relative to parish owned or maintained buildings and offices, to provide that agencies, constitutional officers, or other political subdivisions occupying those buildings and offices shall report data regarding communicable diseases of concern to the public and to otherwise provide with respect thereto* be adopted.

Mr. Epperson mentioned that this is not to bring up a common cold or anything of that nature, but the communicable diseases, such as COVID-19. He said that this is a safety precaution for the citizens, employees, and other members of the public. Mr. Epperson also said that they are not asking for anyone's names being mentioned, just that there has been a certain number of cases.

At this time, Mr. Epperson's motion carried, as shown by the following roll call votes: AYES: Commissioners Burrell, Epperson, Gage-Watts, Hopkins, Jackson, Johnson, Jones, Lazarus, Taliaferro, and Young (10). NAYS: Commissioners Atkins and Chavez (2). ABSENT: None (0). ABSTAIN: None (0).

#### **ORDINANCE NO. 6189 OF 2022**

BY THE CADDO PARISH COMMISSION:

AN ORDINANCE TO ENACT SECTION 2-5 RELATIVE TO PARISH OWNED OR MAINTAINED BUILDINGS AND OFFICES, TO PROVIDE THAT AGENCIES, CONSTITUTIONAL OFFICERS, OR OTHER POLITICAL SUBDIVISIONS OCCUPYING THOSE BUILDINGS AND OFFICES SHALL REPORT DATA REGARDING COMMUNICABLE DISEASES OF CONCERN TO THE PUBLIC AND TO OTHERWISE PROVIDE WITH RESPECT THERETO.

WHEREAS, multiple public agencies, constitutional officers, and other political subdivisions occupy buildings owned, or maintained by the Parish and its employees or contractors;

WHEREAS, reports of communicable diseases such as COVID during the pandemic are needed to safeguard occupants, visitors, and Parish employees and contractors; and

WHEREAS, periodic reports of those communicable diseases will allow the Parish to take preventative measures to protect the public as well as Parish employees and contractors.

NOW, THEREFORE, BE IT ORDAINED, by the Caddo Parish Commission in due, legal and regular session convened, that it hereby adopts Section 205 of the Code of Ordinances to provide as follows:

## SECTION 2.5. REPORTING OF COMMUNICABLE DISEASE IN PARISH FACILITIES

All agencies, constitutional officers, or other political subdivisions that occupy facilities owned or maintained by the Parish shall report periodically to the Parish any occurrence of a communicable disease that is of concern to the public generally.

BE IT FURTHER ORDAINED, that if any provision or item of this ordinance or the application thereof is held invalid, such invalidity shall not affect other provisions, items or applications which can be given effect without the invalid provisions, items or applications, and to this end the provisions of this ordinance are hereby declared severable.

BE IT FURTHER ORDAINED, that this ordinance shall take effect upon adoption.

BE IT FURTHER ORDAINED, that all ordinances or parts thereof in conflict herewith are hereby repealed.

### **ORDINANCES (for introduction by title):**

- *Ordinance No. 6191 of 2022, an ordinance amending the Budget of Estimated Revenues and Expenditures for the Riverboat Fund and Oil and Gas fund in the amount of \$10,000 to provide an appropriation for the Louisiana Advocates for Immigrants in Detention associated with the Highland Center and to otherwise provide with respect thereto*
- *Ordinance No. 6193 of 2022, an ordinance creating the I-49 North Corridor Economic Development District, State of Louisiana," defining the boundaries thereof from which area local sales tax, property tax and hotel occupancy tax increments will be determined and used to finance economic development projects in accordance with and as authorized by Part II of Chapter 27 Of Title 33 of the Louisiana Revised Statutes of 1950, as amended; and providing for other matters in connection with the foregoing.*

### **WORK SESSION MINUTES**

It was **moved by Mr. Jackson**, seconded by Mr. Burrell, *that Work Session Minutes January 31, 2022 be ratified. Motion carried.*

### **RESOLUTIONS**

It was **moved by Mr. Jackson**, seconded by Mr. Burrell, *that Resolution No. 12 of 2022, a resolution authorizing the Parish Administrator to enter into an agreement with the Louisiana Department of Transportation to repave a portion of Louisiana Highway 173, and otherwise providing with respect thereto be adopted.*

Mr. Jackson asked that the fifth paragraph be removed from the resolution.

At this time, Mr. Jackson's motion carried, as shown by the following roll call votes:  
AYES: Commissioners Atkins, Burrell, Chavez, Epperson, Gage-Watts, Hopkins, Jackson, Johnson, Jones, Lazarus, Taliaferro, and Young (12). NAYS: None (0). ABSENT: None (0). ABSTAIN: None (0).

### **RESOLUTION NO. 12 OF 2022**

BY THE CADDO PARISH COMMISSION:

A RESOLUTION AUTHORIZING THE PARISH ADMINISTRATOR TO ENTER INTO AN AGREEMENT WITH THE LOUISIANA DEPARTMENT OF TRANSPORTATION TO REPAVE A PORTION OF LOUISIANA HIGHWAY 173, AND OTHERWISE PROVIDING WITH RESPECT THERETO.

WHEREAS, Louisiana Highway 173 from Pierre Avenue to Hartman Street has been designated by the State of Louisiana as the "Carl Pierson Memorial Highway" by the Louisiana Legislature; and

WHEREAS Louisiana Highway 173 is a major thoroughfare and corridor for residential and commercial traffic within Caddo Parish; and

WHEREAS Amazon distribution center will likely use Louisiana Highway 173 as the quickest route to get access to I-49 south and I-20 east; and

WHEREAS the portion of Louisiana Highway 173 from Pierre Avenue to Hartman Street is in disrepair; and

WHEREAS, the City of Shreveport has begun the process of moving the water lines to the side walk to help solve the water leakage and Louisiana Highway 173 will be suitable for repaving once the City of Shreveport does drainage work on the road;

NOW, THEREFORE, BE IT RESOLVED by the Caddo Parish Commission in due, regular and legal session convened, that the Caddo Parish Commission does hereby authorize the Caddo Parish Administrator to enter into an agreement with the Louisiana Department of Transportation and Development to repave the afore-mentioned portion of Highway 173, once the City of Shreveport has completed drainage repairs.

BE IT FURTHER RESOLVED that a copy of this resolution be provided to, Senator Gregory Tarver, Representative Sam Jenkins, Dr.

Shawn Wilson, Secretary of the Louisiana Department of Transportation and Development, and Secretary Don Pierson of the Louisiana Economic Department.

BE IT FURTHER RESOLVED if any provision or item of this resolution or the application thereof is held invalid, such invalidity shall not affect other provisions, items or applications which can be given effect without the invalid provisions, items or applications, and to this end, the provisions of this resolution are hereby declared severable.

BE IT FURTHER RESOLVED that this resolution shall take effect immediately.

BE IT FURTHER RESOLVED that all resolutions or parts thereof in conflict herewith are hereby repealed.

It was **moved by Mr. Young**, seconded by Mr. Jackson, *that Resolution No. 13 of 2022, a resolution to request that the Department of Homeland Security take immediate action to correct systemic problems within the eight ICE Detention Centers in Louisiana and to request that the House Homeland Security Committee investigate these systemic problems and provide oversight and accountability to ensure the safety of asylum seekers and other immigrants and the community, and to otherwise provide with respect thereto* be adopted.

Mr. Young said that this resolution is to request the federal government to correct some oversight and problems that are going on in the detention centers.

At this time, Mr. Young's motion carried, as shown by the following roll call votes: AYES: Commissioners Atkins, Burrell, Chavez, Epperson, Gage-Watts, Hopkins, Jackson, Johnson, Jones, Lazarus, Taliaferro, and Young (12). NAYS: None (0). ABSENT: None (0). ABSTAIN: None (0).

#### **RESOLUTION NO. 13 OF 2022**

BY THE CADDO PARISH COMMISSION:

A RESOLUTION TO REQUEST THAT THE DEPARTMENT OF HOMELAND SECURITY TAKE IMMEDIATE ACTION TO CORRECT SYSTEMIC PROBLEMS WITHIN THE EIGHT ICE DETENTION CENTERS IN LOUISIANA AND TO REQUEST THAT THE HOUSE HOMELAND SECURITY COMMITTEE INVESTIGATE THESE SYSTEMIC PROBLEMS AND PROVIDE OVERSIGHT AND ACCOUNTABILITY TO ENSURE THE SAFETY OF ASYLUM SEEKERS AND OTHER IMMIGRANTS AND THE COMMUNITY, AND TO OTHERWISE PROVIDE WITH RESPECT THERETO

WHEREAS the state of Louisiana has more immigration detention centers (8) than any other state except Texas and these detention centers are receiving thousands of asylum seekers from the U.S./Mexico border who are transported to Louisiana, incarcerated here at significant cost to taxpayers, and often released within a few weeks to a few months to reunite with their families or sponsors in various parts of the United States and prepare for their asylum hearings and;

WHEREAS many of these asylum seekers are fleeing horrific conditions, including religious persecution, totalitarian dictatorships, political violence, torture, and even genocide, and many have experienced violence at the hands of their own governments or fled after their family members were killed; and

WHEREAS, the United States is a signatory to three international treaties that establish the legal right to seek asylum in a safe country for anyone fleeing persecution, torture, or violence: the Geneva Convention, the Convention Against Torture, and the 1967 Refugee Protocol; and

WHEREAS, U.S. taxpayers are paying millions of dollars to private prisons companies to incarcerate asylum seekers in Louisiana at an average cost of \$133.00 per immigrant per day, with guaranteed payments for a minimum number of 4,605 beds in Louisiana, yet those companies are failing to comply with their government contracts by not providing potable drinking water, nutritious food, and

safe and sanitary living conditions, by denying medical care even for life threatening conditions, and by failing to provide safe and free transportation to an airport or bus station to all immigrants who are released, all of which are required by ICE's own 2011 Performance Based National Detention Standards; and

WHEREAS, local and national human rights organizations have documented and filed over 20 civil rights complaints in the past year alone detailing egregious human rights abuses, including unsanitary conditions, torture and physical abuse, in the ICE detention centers in Louisiana and Mississippi; and

WHEREAS, investigators at the Department of Homeland Security have already recommended that ICE stop sending immigrants to one of the Louisiana detention centers (Winn Correctional Center) because of "a culture and conditions that can lead to abuse, mistreatment, and discrimination," as well as serious plumbing deficiencies and non functional housing unit smoke barrier doors, yet immigrants are still being sent to this detention center; and

WHEREAS, in July of 2021, Louisiana Advocates for Immigrants in Detention and other organizations sent a letter to the Department of Homeland Security asking that they address the egregious violations of ICE's standards for releasing immigrants that put their safety at risk resulting in immigrants left stranded at airports, bus stations, and with a few even going missing for a few days, yet six months later most of the ICE detention centers in Louisiana continue to violate these standards every day, often telling families that their family member will not be released from detention unless they agree to pay for a taxi of anywhere from \$200-\$600, when the facility is legally responsible for providing free transportation to the bus station or airport; and

WHEREAS, volunteers from at least ten local churches, as part of the statewide network Louisiana Advocates for Immigrants in Detention, have stepped in to facilitate the safe transport of over 1200 immigrants from 55 countries released from Louisiana and Mississippi detention centers through Shreveport to reunite with their families or sponsors in the United States during the past ten months, and have provided transportation, shelter, meals, clothing, toiletries, translation, and access to phones and internet, but are unable to fully address the ongoing needs created by the ICE New Orleans Field Office's failure to ensure that its detention centers comply with their contracts by providing free and safe transportation to a bus station or airport for all immigrants who are released; and

NOW, THEREFORE, BE IT RESOLVED, by the Caddo Parish Commission in due, legal and regular session convened that the that the Caddo Parish Commission requests that the White House and the Department of Homeland Security take immediate action to conduct a comprehensive investigation of the ICE New Orleans Field Office and the Louisiana ICE detention centers and all of the civil rights complaints made against them and to address the human rights violations against asylum seekers and other immigrants.

BE IT FURTHER RESOLVED, that the Caddo Parish Commission requests that the House Department of Homeland Security Oversight Committee investigate the systemic problems within the ICE New Orleans Field Office and its detention centers and provide oversight and accountability to ensure an end to the human rights violations.

BE IT FURTHER RESOLVED, that the Caddo Parish Commission requests that the Department of Homeland Security take immediate steps to address the violations around release protocols and ensure that the ICE New Orleans Field Office comes into compliance with the Performance Based National Detention Standards for releases by:

- Ensuring that detention center staff provide free transportation to all individuals being released, to either a full-service bus station, an airport, or to a nonprofit that is prepared to help them make travel arrangements to reunite with their families or sponsors.
- Providing access to interpreters and translated materials to inform them of their post-release transportation options and during the entire release process.
- Facilitating free communication with families or sponsors about releases prior to them happening.
- Ensuring that there are public, accessible materials outlining the post-release transportation options for each of the nine detention centers in Louisiana and Mississippi.

BE IT FURTHER RESOLVED, that a copy of this resolution be sent to the Department of Homeland Security, the White House Office on Intergovernmental Affairs, and to the Chair of the House Department of Homeland Security Oversight Committee, Representative Bennie Thompson.

BE IT FURTHER RESOLVED, that all resolutions or parts thereof in conflict herewith are hereby repealed.

It was **moved by Mr. Epperson**, seconded by Mr. Jackson, *that Resolution No. 14 of*

2022, a resolution urging and requesting the Louisiana Legislature to modify LA R.S. 42:17.1 to allow unlimited agenda items during meetings of public bodies held via electronic means, and to otherwise provide with respect thereto be adopted.

Mr. Epperson said that elected officials should be able to take up all matters on behalf of their citizens. Mr. Burrell agreed.

Mr. Jackson suggested that Legal research the legislation that allowed the State Bond Commission to meet virtually irrespective of a pandemic.

Mr. Hopkins understands the needs for teleconference meetings, but is concerned with the limitation of exchange with the citizens. He supports this resolution, but wants to ensure that the citizens are a part of the process.

Mr. Chavez wants to know if it will be at the decision of the President of when to have a virtual meeting or will it be a majority of the Commission? Mr. Epperson said that this resolution is so that all legislation can be put on the agenda, not just pandemic related legislation.

Mr. Burrell suggested that the majority of the Commission should be able to decide. Mr. Chavez then wanted to know if there was a tie situation. Mr. Atkins said that there are some issues that need to be worked through and vetted.

Mr. Taliaferro said that there were items that were not COVID related that suffered during the pandemic and could not be handled in a timely manner. He said that he is in support of this resolution as well as Mr. Hopkins' comments regarding citizens.

Attorney Frazier explained that this resolution addresses the Public Meetings Law and exceptions to the Public Meetings Law.

At this time, Mr. Epperson's motion carried, as shown by the following roll call votes: AYES: Commissioners Atkins, Burrell, Chavez, Epperson, Gage-Watts, Hopkins, Jackson, Johnson, Jones, Lazarus, Taliaferro, and Young (12). NAYS: None (0). ABSENT: None (0). ABSTAIN: None (0).

#### **RESOLUTION NO. 14 OF 2022**

BY THE CADDO PARISH COMMISSION:

A RESOLUTION URGING AND REQUESTING THE LOUISIANA LEGISLATURE TO MODIFY LA R.S. 42:17.1 TO ALLOW UNLIMITED AGENDA ITEMS DURING MEETINGS OF PUBLIC BODIES HELD VIA ELECTRONIC MEANS, AND TO OTHERWISE PROVIDE WITH RESPECT THERETO

WHEREAS, La.R.S. 42:17.1 (A)(1) and (2) provide that public bodies in Louisiana can hold public meetings via electronic means when the following conditions are met:

- 1) The governor has declared a state of emergency or disaster involving a geographic area within the jurisdiction of the public body and the nature of the emergency or disaster would cause a meeting of the public body conducted pursuant to the other provisions of this Chapter to be detrimental to the health, safety, or welfare of the public.
- 2) The presiding officer of the public body certifies on the notice of the meeting that the agenda of the meeting is limited to one or more of the following:
  - a) Matters that are directly related to the public body's response to the disaster or emergency and are critical to the health, safety, or welfare of the public.
  - b) Matters that if they are delayed will cause curtailment of vital public services or severe economic dislocation and hardship.
  - c) Matters that are critical to continuation of the business of the public body and that are not able to be postponed to a meeting held in accordance with the other provisions of this Chapter due to a legal requirement or other deadline that cannot be postponed or delayed by the public body.
  - d) Other matters that are critical or time-sensitive and that in the determination of the presiding officer should not be delayed; however, such matters shall not be considered at the meeting unless the members of the body present at the meeting approve the he consideration of the matters by a two-thirds vote and;

WHEREAS the gubernatorially declared emergency regarding the COVID 19 Pandemic has been ongoing for almost two years, with several spikes in cases rendering it unsafe for public bodies

to meet in person during those spikes; and

WHEREAS, the limited agenda items allowed during meetings held via electronic means are not sufficient to cover all items to be addressed by a public body; and

WHEREAS, electronic meetings with limited agendas cause undue delay of important matters that need to be addressed, when they do not they fall in one of the statutory categories; and

WHEREAS, electronic meetings with limited agendas cause exceedingly long agendas during in-person meetings, which result in an inefficient use of citizen participants' and public officials' time.

NOW, THEREFORE, BE IT RESOLVED, by the Caddo Parish Commission in due, legal and regular session convened that the Caddo Parish Commission hereby urges and requests the Louisiana Legislature to remove all agenda restrictions on electronic meetings held during gubernatorially declared disasters or emergencies.

BE IT FURTHER RESOLVED, that this resolution is effective immediately upon its passage.

BE IT FURTHER RESOLVED, that this resolution will be forwarded to the President of the Louisiana Senate, Speaker of the Louisiana House, and the Caddo Parish legislative delegation.

BE IT FURTHER RESOLVED, that all resolutions or parts thereof in conflict herewith are hereby repealed.

It was **moved by Mr. Hopkins**, seconded by Mr. Jackson, *that Resolution No. 15 of 2022, a resolution approving the issuance of not exceeding Four Million Nine Hundred Thousand Dollars (\$4,900,000) of Sales Tax Refunding Bonds, Series 2022, of the North Caddo Hospital Service District of the Parish of Caddo, State of Louisiana, and providing for other matters in connection therewith be adopted.*

**Substitute motion by Mr. Chavez**, seconded by Mr. Jackson, *to englobo and adopt the following resolutions:*

- *Resolution No. 15 of 2022, a resolution approving the issuance of not exceeding Four Million Nine Hundred Thousand Dollars (\$4,900,000) of Sales Tax Refunding Bonds, Series 2022, of the North Caddo Hospital Service District of the Parish of Caddo, State of Louisiana, and providing for other matters in connection therewith*
- *Resolution No. 16 Of 2022, an ordinance creating the "I-49 North Corridor, State of Louisiana;" defining the boundaries thereof from which area local sales tax, property tax and hotel occupancy tax increments will be determined and used to finance economic development projects in accordance with and as authorized by Part II of Chapter 27 of Title 33 of the Louisiana Revised Statutes of 1950, as amended; and providing for other matters in connection with the foregoing*

At this time, Mr. Chavez's substitute motion carried, as shown by the following roll call votes: AYES: Commissioners Atkins, Burrell, Chavez, Epperson, Gage-Watts, Hopkins, Jackson, Johnson, Jones, Lazarus, Taliaferro, and Young (12). NAYS: None (0). ABSENT: None (0). ABSTAIN: None (0).

#### **RESOLUTION NO. 15 OF 2022**

BY THE CADDO PARISH COMMISSION:

A RESOLUTION APPROVING THE ISSUANCE OF NOT EXCEEDING FOUR MILLION NINE HUNDRED THOUSAND DOLLARS (\$4,900,000) OF SALES TAX REFUNDING BONDS, SERIES 2022, OF THE NORTH CADDO HOSPITAL SERVICE DISTRICT OF THE PARISH OF CADDO, STATE OF LOUISIANA, AND PROVIDING FOR OTHER MATTERS IN CONNECTION THEREWITH.

WHEREAS, the Board of Commissioners of the North Caddo Hospital Service District of the Parish of Caddo, State of Louisiana, adopted a resolution on January 25, 2022, requesting that this Commission approve the issuance of not exceeding Four Million Nine Hundred Thousand Dollars (\$4,900,000) of Sales Tax Refunding Bonds, Series 2022, of said District for the purposes of refunding all or a portion of its outstanding Taxable Sales Tax Bonds, Series 2014, and paying the costs of issuance thereof; and

WHEREAS, in compliance with the terms and provisions of Article VI, Section 15 of the Constitution of the State of Louisiana of 1974, it is now the desire of this Commission to approve said borrowing;

NOW, THEREFORE, BE IT RESOLVED by the Caddo Parish Commission (the "Commission"), acting as the governing authority of Caddo Parish, Louisiana (the "Parish"), meeting in legal and regular session, that:

SECTION 1. In compliance with the provisions of Article VI, Section 15 of the Constitution of the State of Louisiana of 1974, and in accordance with the request of the Board of Commissioners of the North Caddo Hospital Service District of the Parish of Caddo, State of Louisiana, the governing authority of said North Caddo Hospital Service District of the Parish of Caddo, State of Louisiana (the "District"), this Commission hereby approves the issuance of not exceeding Four Million Nine Hundred Thousand Dollars (\$4,900,000) of Sales Tax Refunding Bonds, Series 2022, of the District (the "Bonds") for the purposes set forth in the preamble hereto. The Bonds are to be payable, equally with the District's Sales Tax Refunding Bonds, Series 2019, from and secured by an irrevocable pledge and dedication of the net avails or proceeds of the District's special one percent (1%) sales and use tax approved at an election held in the District on April 21, 2012 (the "Tax"), subject only to the prior payment of the reasonable and necessary costs and expenses of collection and administering the Tax. The Bonds shall bear interest at a rate not exceeding 5% per annum and shall mature no later than September 1, 2036. Neither Caddo Parish nor this Commission shall in any way be liable for the payment of principal and/or interest on the Bonds.

This resolution having been submitted to a vote, the vote thereon was as follows:

YEAS: Atkins, Burrell, Chavez, Epperson, Gage-Watts, Hopkins, Jackson, Johnson, Jones, Lazarus, Taliaferro, and Young (12).

NAYS: None (0).

ABSENT: None (0).

And the resolution was declared adopted on this, the 3rd day of February, 2022.

/s/ Jeff Everson  
Clerk

/s/John E. Atkins  
President

#### RESOLUTION NO. 16 OF 2022

BY THE CADDO PARISH COMMISSION:

A RESOLUTION GIVING NOTICE OF INTENTION TO CREATE AN ECONOMIC DEVELOPMENT DISTRICT KNOWN AS THE I-49 NORTH CORRIDOR ECONOMIC DEVELOPMENT DISTRICT, STATE OF LOUISIANA, AND OTHERWISE PROVIDING WITH RESPECT THERETO.

WHEREAS, Part II, Chapter 27, Title 33 of the Louisiana Revised Statutes of 1950, as amended (La. R.S. 33:9038.31, et seq.) (the "EDD Act") authorizes municipalities, parishes and certain other local governmental subdivisions to create economic development districts to carry out the purposes of the EDD Act, which economic development districts are political subdivisions of the State of Louisiana and possess such power and authority and have such duties as provided by the EDD Act and other law; and,

WHEREAS, the Parish of Caddo, State of Louisiana (the "Parish"), acting through this Parish Commission as its governing authority, desires to avail itself of the EDD Act to create an economic development district to be called the "North Caddo Economic Development District, State of Louisiana" (the "District"), in accordance with La. R.S. 33:9038.32, in which local and State sales tax and property tax increments are expected to be determined and used to fund infrastructure for the District and other Caddo Parish economic development projects; and,

WHEREAS, La. R.S. 33:9038.34(O) provides that this governing authority may create a special trust fund for the furtherance of economic development projects, as defined in the EDD Act, into which the incremental increases in such sales, property and hotel occupancy taxes shall be deposited and loaned, granted, donated, or pledged in furtherance of economic development projects as defined in the EDD Act; and,

WHEREAS, in accordance with the EDD Act, particularly La. R.S. 33:9038.32(B) and La. R.S. 33:9038.39, the Parish now desires to give notice of its intention and to hold a public hearing relative to the proposed creation of the District, including a description of the boundaries of the District and containing a map showing the boundaries of the District; and,

NOW THEREFORE, BE IT RESOLVED by the Caddo Parish Commission, acting as the governing authority of the Parish of Caddo, State of Louisiana, that:

THE CADDO PARISH COMMISSION HEREBY RESOLVES:

SECTION ONE: Intention to Create Economic Development District. In accordance with the EDD Act, and particularly La. R.S. 33:9038.32 and La. R.S. 33:9038.39, the Parish does hereby give notice of its intention to create an economic development district to be called the "I-49 North Corridor Economic Development District, State of Louisiana" and to collect tax increments pursuant to La. R.S. 33:9038.39 for the purpose of paying the costs of economic development projects as defined in La. R.S. 33:9038.34(M) and La. R.S. 33:9038.36.

The proposed economic development district shall have the boundaries described in Exhibit A to this resolution.

SECTION TWO: Notice of Intention. The Clerk of the Commission is authorized and directed to publish a notice of intention, in substantially the following form, which notice shall be published two (2) times in the Parish's official journal prior to the public hearing described therein:

\* \* \* \* \*

**NOTICE OF INTENTION TO CREATE AN  
ECONOMIC DEVELOPMENT DISTRICT  
IN THE PARISH OF CADDO, STATE OF LOUISIANA**

NOTICE IS HEREBY GIVEN that the Caddo Parish Commission (the "Commission"), acting as the governing authority of the Parish of Caddo, Louisiana (the "Parish"), proposes to consider the adoption of an ordinance, pursuant to La. R.S. 33:9038.32, creating an economic development district within the Parish to be called the "North Caddo Economic Development District, State of Louisiana" (the "District").

NOTICE IS HEREBY FURTHER GIVEN that upon the creation of the District, the Governing Authority, in its capacity as the governing authority of the newly created District, further proposes to consider the adoption of ordinances, pursuant to La. R.S. 33:9038.39, collecting tax increments, for the purpose of financing economic development projects, as defined in La. R.S. 33:9038.34(M) and La. R.S. 33:9038.36(the "District Taxes"). The proceeds of the incremental revenues of Parish sales, property and hotel occupancy axes designated by this Governing Authority for such purposes, will be deposited in a special trust fund to be used for the furtherance of economic development projects within the District and Caddo Parish, all pursuant to the authority of Part II, Chapter 27, Title 33 of the Louisiana Revised Statutes of 1950, as amended (La. R.S. 33:9038.31, *et seq.*).

NOTICE IS HEREBY FURTHER GIVEN that the Commission will meet in open and public session on March 3, 2022 at three-thirty o'clock (3:30) p.m., at the Government Plaza, 505 Travis Street, Shreveport, in Caddo, Louisiana, to hear any objections to the creation of the District as described above.

A description of the boundaries of the proposed District, and a map of the proposed District, are as follows:

7.498 acres to be defined as from: That part of the Southeast Quarter (SE1/4) of Section Thirteen (13), Township Twenty-two (22) North, Range Fifteen (15) West, lying South of the North right of way line of the Hosston-Miller's Bluff Road and East of the West Bank of Kelly Bayou Canal and all of the South Half of the Southwest Quarter (S1/2 of SW1/4) of Section Thirteen (13), Township Twenty two (22) North, Range Fifteen (15) West, lying East of the West bank of Kelly Bayou Canal

\* \* \* \* \*

SECTION THREE: Public Hearing. At the date, time and place mentioned in the aforesaid Notice of Intention, or at such other time and place as may be determined by the Commission and properly advertised, this Governing Authority will meet in open and public session, to hear any objections to the proposed creation of the District, and may consider the adoption of an ordinance creating the district.

SECTION FOUR: Authorization of Officers. The Parish Administrator and Clerk of the Commission are hereby authorized and empowered to do all acts, sign any and all instruments or documents, and do all things necessary and proper in order to carry out the purpose and provisions of this resolution.

SECTION SIX: Effective Date. This resolution shall become effective upon publication.

SECTION SEVEN: Repeal of other Resolutions. All resolutions or parts thereof in conflict herewith are hereby repealed, specifically Resolution No. 81 of 2021.

It was **moved by Mr. Epperson**, seconded by Mr. Jackson, *that Resolution No. 17 of*

2022, urge and request the Louisiana Department of Natural Resources to consider the negative impacts of oil and gas drilling in or near urban areas, to implement rules combating those negative impacts, and to otherwise provide with respect thereto be adopted.

Mr. Epperson said that this came out of the Natural Resources Committee and asked for favorable passage of this resolution.

Mr. Young explained that Mr. Epperson brought this to the Natural Resources Committee; some were already law, and some were recommendations. He worked with Mr. Epperson to amend every complaint that the industry groups pointed out. They wrote again expressing the same discontentment with the ordinance. Dr. Siska and some others pointed out that the citizens are asking for small changes, such as 500 more feet further from a dwelling or property line in a densely populated area. I also don't want us to get into the business of trying to develop expertise in the regulation of oil and gas, Mr. Young said, I think it's our job to forward a reasonable edited set of complaints to the experts and then get on to the business that is imposed on us by our charter.

Mr. Hopkins asked that the following letters be placed in the record:

Resolution 17 of 2022 currently proposed on the Caddo Parish working session agenda scheduled on February 3, 2022, is of serious concern to Louisiana's oil and natural gas industry.

- The proposed provisions outlined in the resolution are unnecessarily restrictive and essentially impose a de facto moratorium on oil and natural gas operations in the parish. The industry encourages Caddo Parish to work with industry and directly engage with [DNR's Office of Conservation](#) to find solutions on issues of concern.
- Caddo Parish has had a productive working relationship with the natural gas and oil industry. Since 2014, the natural gas and oil industry has annually provided [more than 5,000 jobs](#) to Caddo Parish residents. with annual wages totaling over \$190 million.
- In addition to paying wages to residents of the Parish, the natural gas and oil industry paid nearly [\\$100 million in ad valorem taxes](#) directly to Caddo Parish from 2015-2019.
- As industry has done previously, and as we continue to do with other parishes in the state, the oil and natural gas industry is committed to working with Caddo going forward for the best interests of all parties. Currently, industry is working closely with Bossier Parish to update their noise ordinance which can be a model for surrounding parishes.
- The overly stifling provisions in Resolution 17 would have a crippling economic impact on Caddo parish and on the investments made by the operating companies, driving business and industry investments to other states and even other Parishes with better business environments for economic growth.

*See below for a summary of prioritized industry concerns around some of the proposed provisions:*

#### Setbacks.

- The proposed 1000-1500' setback does not appear to be based on any scientific study or analysis.
- This requirement would rule out a significant portion of leased acreage everywhere in Caddo Parish, resulting in a de facto moratorium.
- If enacted, this provision would be one of the most prescriptive setback in the country and will eliminate nearly all oil and natural gas activity in Caddo Parish.
- If new buffer rules effectively prevent drilling activity or inhibit a lessee's ability to develop, the parish would face potential liability from lessees in addition to lessors/mineral rights owners for committing a regulatory taking without compensation
- A [study on setback proposals in Colorado](#) showed substantial financial effects from similar provisions.

#### Nighttime Completions Operations.

- This limitation will significantly increase the time and cost for operators and service companies. Moving to day-time only operations would more than double the completion costs and lead to reduced investment in and oil and gas assets as these projects will lower investment potential.
- Many have indicated this provision, specifically, would likely lead them to move their business and future investment to other states, like Texas.
- By requiring the job to stop at the end of every day, a nighttime completions ban will lead to increased operational and safety risks because thousands of feet of coil tubing will need to be pulled at the end of each shift. Also, the increased frequency of job shutdowns will lead to increased wear of pressure containing and safety equipment, an additional, unnecessary risk.
- Moving to day-time only operations would increase the duration of the job and

prolong any of the community's concerns. Not allowing 24-hour operations will only increase the frequency of operation startups and shutdowns resulting in higher noise levels because of engines starting up and ramping up to the desired horsepower.

Financial surety and arbitration provision.

- This opens up significant ambiguity and potential for misuse/abuse

Provisions for which regulatory mechanisms already exist.

- Sound suppression – noise ordinances
- Dust mitigation for entrance roads – LDNR Haynesville Shale Order
- Public notification/participation – LDNR requires adequate public notice prior to issuance of drilling permits
- Transportation identification – DOTD placarding requirements
- [Seismic monitoring](#) – USGS currently does this monitoring and makes the data available to the public.
- Resource: [DNR Louisiana Hydraulic Fracturing Regulations](#).

Hydraulic Fracturing

- [Hydraulic fracturing](#) is modern technology, [safely and responsibly](#) developing vast reserves of oil and natural gas from shale and other tight-rock formations. It's the backbone of an energy renaissance that's making the U.S. more prosperous and safer in the world today. ([EID Health](#))
- The combination of industry standards, best practices and effective state and federal regulation is protecting communities and the environment – while making available increasing volumes of cleaner- burning natural gas that is allowing the U.S. to lead the world in reducing carbon emissions from electricity generation.

Closing

- The natural gas and oil industry has been and continues to provide jobs and tax revenue to Caddo Parish. Restrictive provisions would eliminate jobs, tax revenue and economic activity.
- Operators represented by LMOGA and LOGA are good actors who would like to work with Parish officials to resolve potential issues or misunderstandings, similar to the ongoing, collaborative effort to update noise ordinances in Bossier Parish.
- Unnecessary, burdensome regulations will cause operators and service companies to reevaluate whether or not they continue to do business in Caddo parish.
- Louisiana continues to be at the forefront of responsibly sourced oil and natural gas, and as the global demand for oil remains steady and the demand for natural gas is projected to double by 2050, Louisiana—and Caddo Parish— stand to benefit.

*Comments on behalf of the Louisiana Mid-Continent Oil & Gas Association & the Louisiana Oil & Gas Association for Public Record, February 3, 2022*

Louisiana is at the forefront of responsibly sourced oil and natural gas, and as the global demand for oil remains steady and the demand for natural gas is projected to double by 2050, Louisiana— and Caddo Parish— stand to benefit. Resolution No. 17 of 2022 on the Caddo Parish Commission agenda today is of serious concern to Louisiana's oil and natural gas industry, and it should be of serious concern for the residents and business owners of Caddo as well. The proposed provisions outlined in the resolution are unnecessarily restrictive and essentially impose a de facto moratorium on oil and natural gas operations in the parish. The industry encourages Caddo Parish to work together with representatives from the industry and directly engage with [DNR's Office of Conservation](#) to find solutions on issues of concern. Caddo Parish has had a productive working relationship with the oil and natural gas industry for decades. Since 2014, our industry has annually provided [more than 5,000 jobs](#) to Caddo Parish residents, with annual wages totaling over \$190 million. In addition to providing good paying jobs to the residents of Caddo, the natural gas and oil industry paid nearly [\\$100 million in ad valorem taxes](#) directly to Caddo Parish from 2015-2019. That's \$100 million for roads and bridges, emergency services, and schools. Industry continues to work collaboratively with other parishes in the state and is committed to working with Caddo Parish going forward to find solutions to address your concerns. Operators represented by LMOGA and LOGA are good actors who would like to work with Parish officials to resolve potential issues or misunderstandings, similar to the ongoing, collaborative efforts made in Bossier Parish to update their noise ordinance, which can be a model for Caddo Parish. The stifling provisions in Resolution 17 would have a crippling economic impact on Caddo parish and on the investments made by the operating companies, driving business and industry investments to other states and even other Parishes with better business environments for economic growth. Unnecessary, burdensome regulations will cause operators and service companies to reevaluate whether or not they continue to do

business in Caddo parish, which would eliminate much needed jobs, tax revenue, and economic activity. While passing this resolution today may not immediately make any changes to the rule of law when it comes to drilling, these actions send a strong signal to the industry that Caddo Parish is closed for business and has no interest in working with oil and natural gas companies. We respectfully request the Commission to vote against the resolution and instead work collaboratively with the industry and the State of Louisiana to resolve community concerns specific to Haynesville Shale activity. Tommy Fauchoux, President, LMOGA Mike Moncla, President, LOGA

To the Members of the Caddo Parish Commission:

It has come to the attention of the oil and natural gas industry, jointly represented by the Louisiana Mid-Continent Oil & Gas Association (LMOGA), the Louisiana Oil & Gas Association (LOGA) and the Louisiana Association of Business and Industry (LABI), (collectively referred to herein as “the Associations”), that the Caddo Parish Commission has once again proposed a resolution to “urge and request the Louisiana Department of Natural Resources to consider the negative impacts of oil and gas drilling in or near urban areas, implement rules to combat these negative impacts, and to otherwise provide with respect thereto.” The resolution urges and requests the LDNR to consider implementing changes to oil and gas drilling regulations within the State of Louisiana, particularly within the Haynesville Shale drilling area. The Associations respectfully request the Commission to vote against the resolution and instead work collaboratively with the industry and the State of Louisiana to resolve community concerns specific to Haynesville Shale activity. The provisions outlined in the proposed resolution are unnecessarily restrictive and will create a de facto moratorium on oil and natural gas operations in Caddo Parish. Furthermore, these burdensome provisions will have a crippling economic impact on Caddo Parish and on the investments made by operating companies, driving business and industry investments to other states and even other parishes with a more attractive business climate for economic growth. A de facto moratorium in Caddo Parish is an extreme step that will cause devastating impacts to the Associations’ members and the residents of Caddo Parish. Since 2014, the oil and natural gas industry has annually provided more than 5,000 jobs to Caddo Parish residents with annual total wages of over \$190 million. In addition to paying wages to Caddo parish residents, the industry paid nearly \$100 million in ad valorem taxes directly to the parish from 2015-2019. For many years, the oil and natural gas industry has had a productive working relationship and it is our intention to maintain those relations going forward. Our Associations are currently collaborating with Bossier Parish to update their noise ordinance and we would be happy to do the same with Caddo Parish. The Associations’ members are committed to working collaboratively with Caddo Parish officials and the residents to resolve concerns. Louisiana continues to be at the forefront of responsibly sourced oil and natural gas, and as the global demand for oil remains steady and the demand for natural gas is projected to double by 2050, Louisiana and Caddo Parish stand to benefit. Thank you for your public service and we look forward to collaborating with Caddo Parish.

/s/Stephen Waguespack  
LABI President

/s/Lori LeBlanc  
LMOGA Interim President

/s/Mike Moncla  
LOGA President

Mr. Chavez said that the author was not amenable to adding changes regarding Cross Lake and the \$100 bonds, so he will not be supporting this resolution.

Mr. Taliaferro agreed that the drilling companies should meet with the citizens with regards to their concerns. He also said that everything in this resolution has already been addressed. Mr. Taliaferro said that representatives from the oil and gas industry attended a few of the Commission meetings and “offered an olive branch” to open dialogue with the citizens.

Mr. Burrell said that this resolution is not going to stop the oil and gas industry; it is only showing the concerns that the citizens have.

Mr. Atkins agreed that noise and dust can be a problem, but feels that the industry is working on that. He is concerned that this resolution is going to send a signal to the industry to discourage them from participating in drilling activities in Caddo Parish. Mr. Atkins also pointed out that the industry employs over 5,000 people a year in this Parish as well as the ad valorem taxes that were paid to Caddo Parish. He would like to see them operate in our communities with respect and care for the citizens.

At this time, Mr. Epperson’s motion carried, as shown by the following roll call votes: AYES: Commissioners Burrell, Epperson, Gage-Watts, Jackson, Johnson, Jones, and Young (7). NAYS: Commissioners Atkins, Chavez, Hopkins, Lazarus, and Taliaferro (5). ABSENT: None (0). ABSTAIN: None (0).

#### RESOLUTION NO. 17 OF 2022

BY THE CADDO PARISH COMMISSION:

URGE AND REQUEST THE LOUISIANA DEPARTMENT OF NATURAL RESOURCES TO CONSIDER THE NEGATIVE IMPACTS OF OIL AND GAS DRILLING IN OR NEAR URBAN AREAS, TO IMPLEMENT RULES COMBATING THOSE NEGATIVE IMPACTS, AND TO OTHERWISE PROVIDE WITH RESPECT THERETO

WHEREAS, there has been a surge in Haynesville Shale drilling within Louisiana; and

WHEREAS, more wells are being drilled in or near populous urban areas; and  
WHEREAS, such drilling is causing a disruption to and diminution of the quality of life for citizens of those areas; and

WHEREAS, more stringent drilling regulations are needed to allow the citizens to peacefully co-exist with this increased drilling activity.

NOW, THEREFORE, BE IT RESOLVED, by the Caddo Parish Commission in due, legal and regular session convened, that the Caddo Parish Commission does urge and request the Louisiana Department of Natural Resources to consider implementing and enforcing the following changes for the regulation of horizontal drilling within the State of Louisiana, within the Haynesville Shale drilling area:

1. Well heads shall be placed a minimum of 1,000-1,500 feet from all areas of the property lines of the property upon which a well is drilled.
2. All horizontal drilling pads shall be required to have sound suppression system installed.
3. All entrance roads to drilling sites shall be overlaid with mitigating products as needed to eliminate or minimize dust.
4. No fracking or noise generating activities shall be allowed between the hours of 10:00pm and 7:00am near organized subdivisions within two (2) miles of a drill site.
5. Drilling companies shall meet with residents within the communities surrounding the drilling site, prior to commencing drilling operations and inform citizens of what to expect during drilling activities.
6. All transmission and distribution pipelines, compressor sites, relief valves located near and in residential neighborhoods shall be prominently identified, labeled with product content.
7. Emergency phone numbers for drilling companies shall be highly visible and posted at the entrance of all drilling sites. Phone lines shall be staffed with personnel to monitor all calls in real time at all times.
8. Drilling companies that are authorized and permitted for their operations in Caddo Parish shall contact the appropriate designated parish department and provide the following information:
  - a. Name of drilling company
  - b. Location of well site/name of well site
  - c. Address of home office
  - d. Contact phone number at well site.
  - e. Contact phone number of home office
  - f. Projected date to start drilling
  - g. Projected date to end drilling
9. All trucks that are supplying resources to support the drilling operations, shall be

display the proper DOTD codes or names of the items that they are transporting. This includes, solids, liquids, etc. (waste water, drilling fluids, machine and vehicle maintenance Fluids)

10. All drillers shall be required to present a restorative plan for the trees, shrubs, and natural habitat for animals, that have been displaced because of clearing entrance roads, and drill pad sites. The drilling companies must begin implementation of such plans within ninety days after drilling activity ends at a well site.
11. Drilling companies that are authorized and permitted for their operations in Caddo Parish shall post a \$100,000.00 bond to mitigate any claims by citizens against the drilling company, and shall agree to settle all such claims via arbitration. Arbitrators shall be chosen on a rotating basis from a list of certified arbitrators located in Caddo Parish.
12. Upon completion of drilling activity on a well site, drilling companies shall install seismometers in strategic locations around the well site, record readings and monitor them for a two-year period.

BE IT FURTHER RESOLVED, that if any provision or item or the application thereof is held invalid, such invalidity shall not affect other provisions, items or applications which can be given effect without the invalid provisions, items or applications, and to this end the provisions of this ordinance are hereby declared severable.

BE IT FURTHER RESOLVED, that this resolution shall take effect upon adoption.

BE IT FURTHER RESOLVED, that copies of this resolution shall be forwarded to DNR Secretary Thomas Harris, Governor John Bel Edwards and to the Caddo Parish Legislative Delegation.

BE IT FURTHER RESOLVED, that all resolutions or parts thereof in conflict herewith are hereby repealed.

It was **moved by Mr. Jackson**, seconded by Mr. Hopkins, *that Resolution No. 18 of 2022, a resolution authorizing the Parish Administrator to submit the Lofts at 114 Texas to receive home funds from the Louisiana Housing Corporation, to enter into a cooperative endeavor agreement with the Louisiana Housing Corporation, and otherwise providing with respect thereto* be adopted.

Mr. Jackson said that this is a passthrough.

Mr. Johnson wanted to know if this will commit the Parish to any losses. Mr. Jackson said that this does not the commit the Parish, but it does not prohibit the Parish either.

At this time, Mr. Jackson's motion carried, as shown by the following roll call votes: AYES: Commissioners Atkins, Burrell, Chavez, Epperson, Gage-Watts, Hopkins, Jackson, Johnson, Jones, Lazarus, Taliaferro, and Young (12). NAYS: None (0). ABSENT: None (0). ABSTAIN: None (0).

#### **RESOLUTION NO. 18 OF 2022**

BY THE CADDO PARISH COMMISSION:

A RESOLUTION AUTHORIZING THE PARISH ADMINISTRATOR TO SUBMIT THE LOFTS AT 114 TEXAS TO RECEIVE HOME FUNDS FROM THE LOUISIANA HOUSING CORPORATION, TO ENTER INTO A COOPERATIVE ENDEAVOR AGREEMENT WITH THE LOUISIANA HOUSING CORPORATION, AND OTHERWISE PROVIDING WITH RESPECT THERETO.

WHEREAS, 114 Texas Street has been a long-standing eyesore adjacent to one of the gateways into downtown Shreveport; and

WHEREAS, 114 Texas Street LLC is a minority owned business seeking to put the property back into commerce as a mixed-use development in 2022; and

WHEREAS, that development will generate both temporary construction jobs and permanent business jobs; and

WHEREAS, the Louisiana Housing Corporation has indicated that it is willing to enter into a cooperative endeavor agreement with the Parish of Caddo for the Parish to administer Home Funds for 114 Texas Street LLC; and

NOW, THEREFORE, BE IT RESOLVED by the Caddo Parish Commission in due,

regular and legal session convened, that the Caddo Parish Commission does hereby submit The Lofts at 114 Texas Street to the Louisiana Housing Corporation, for Home Funds to be provided to Caddo Parish to administer to the development.

BE IT FURTHER RESOLVED if any provision or item of this resolution or the application thereof is held invalid, such invalidity shall not affect other provisions, items or applications which can be given effect without the invalid provisions, items or applications, and to this end, the provisions of this resolution are hereby declared severable.

BE IT FURTHER RESOLVED that this resolution shall take effect immediately.

BE IT FURTHER RESOLVED that all resolutions or parts thereof in conflict herewith are hereby repealed.

### **OLD BUSINESS**

It was **moved by Mr. Young**, seconded by Mr. Burrell, *that appointments to the Caddo Parish Planning Commission be delayed until after the Attorney General renders their opinion.*

Mr. Young would like to consider this item during the same meeting that the Commission considers Ordinance No. 6168 of 2022.

Mr. Jackson asked that Mr. Carter Bedford be removed from the list since he lives in the town limits of Greenwood. He also mentioned that there are developers who are ready to move their projects along and are stuck in the zoning process. He suggested to appoint the members who are willing to serve to get those citizens who are stuck in that process.

**Substitute motion by Mr. Chavez**, seconded by Mr. Lazarus, *that Laura Neubert be appointed to the Caddo Parish Planning Commission.*

Mr. Chavez agreed with Mr. Jackson. He said that this is the most expedient way to get the citizens the help they need. He also said that Ms. Neubert has the institutional knowledge and would make a good appointee to the board.

**Amendment by Mr. Epperson**, seconded by Mr. Chavez, *that Kay Proby-Waller also be appointed to the Caddo Parish Planning Commission.*

**Amendment by Mr. Johnson**, seconded by Mr. Jackson, *that Kay Proby-Waller, Laura Neubert, Phillis Hart, and Damien Humphries be appointed to the Caddo Parish Planning Commission.*

Mr. Burrell still has an issue with the urban Commissioners who does not have any rural areas in their districts.

**Call for the Question by Mr. Jones**, seconded by Mr. Johnson. Motion carried, as shown by the following roll call votes: AYES: Commissioners Atkins, Burrell, Chavez, Epperson, Gage-Watts, Jackson, Johnson, Jones, Taliaferro, and Young (10). NAYS: Commissioners Hopkins and Lazarus (2). ABSENT: None (0). ABSTAIN: None (0).

At this time, Mr. Johnson's motion failed, as shown by the following roll call votes: AYES: Commissioners Burrell, Epperson, Gage-Watts, Jackson, Johnson, and Jones (6). NAYS: Commissioners Atkins, Chavez, Hopkins, Lazarus, Taliaferro, and Young (6). ABSENT: None (0). ABSTAIN: None (0).

At this time, Mr. Chavez's motion failed, as shown by the following roll call votes: AYES: Commissioners Chavez, Lazarus, and Taliaferro (3). NAYS: Commissioners Atkins, Burrell, Epperson, Gage-Watts, Hopkins, Jackson, Johnson, Jones, and Young (9). ABSENT: None (0). ABSTAIN: None (0).

At this time, Mr. Young's original motion carried, as shown by the following roll call votes: AYES: Commissioners Atkins, Burrell, Epperson, Hopkins, Jackson, Johnson, Lazarus, Taliaferro, and Young (9). NAYS: Commissioners Gage-Watts, Johnson, and Jones (3). ABSENT: None (0). ABSTAIN: None (0).

It was **moved by Mr. Jackson**, seconded by Mrs. Gage-Watts, *to reconsider the vote regarding appointing members to the Caddo Parish Planning Commission.*

Mr. Jackson reiterated that there are business owners who are stuck in the zoning process because the Parish does not have a process for them to move forward. He understands that there are some things that need to be sorted out, but would like to "walk and chew gum at the same time".

Mr. Lazarus said that some of the Commissioners have not had the opportunity to add their members yet. He suggested delaying this. Mr. Hopkins agreed.

Mr. Jackson withdrew his motion.

**NEW BUSINESS**

It was **moved by Mr. Young**, seconded by Mr. Epperson, *that Poltavas Black, Fania Roots, and Willie H. Arbuthnot be appointed to the Caddo Parish Broadband Committee. Motion carried*, as shown by the following roll call votes: AYES: Commissioners Atkins, Burrell, Chavez, Epperson, Gage-Watts, Hopkins, Jackson, Johnson, Jones, Lazarus, Taliaferro, and Young (12). NAYS: None (0). ABSENT: None (0). ABSTAIN: None (0).

There was no further discussion to come before the Commission, so the meeting was adjourned at 6:57 p.m.

  
Michelle Nations  
Assistant Commission Clerk

  
John E. Atkins  
President

# State of Louisiana



## Parish of Caddo

In the Name and By the Authority of The  
Caddo Parish Commission

### RESOLUTION OF RECOGNITION

to

**CHRISTOPHER THOMAS, Jr.**

**WHEREAS**, the Caddo Parish Commission is always pleased to recognize and honor those sons and daughters of Caddo Parish who have gone forth to gain singular and outstanding personal achievements, and in so doing, reflect favorably and positively upon their home community; and

**WHEREAS**, **MR. CHRISTOPHER THOMAS, Jr.**, a Shreveport native and Senior at Calvary Baptist Academy, has been honored to be an important part of the Calvary Baptist football team that brought Calvary its 3<sup>rd</sup> state title and first title for Coach Rodney Guin during the 2020 season, his latest accomplishments include his participation in the Dream All-American Bowl played in January 2022 at AT&T Stadium in Arlington, TX;

**WHEREAS**, The Dream All-American Bowl is a high school football all-star showcase with players from across the country, sponsored by Recruit Nation and Dream Scouting Network and broadcast to a national audience, the game and related events were held over Martin Luther King, Jr. weekend as a celebration of the excellence, commitment and sacrifice made by the players and their families; and

**WHEREAS**, Mr. Thomas has served the offensive line with pride as the right tackle, but he has also demonstrated that he is more than the accomplishments that he earns as #53, he is also a humble leader who is as known for his work ethic and compassion as he is for clearing the way for teammates to shine on the field. Thomas' leadership recently won him another kind of contest when his design won AFS Logistics' Christmas Card contest, resulting in a large donation to his school and a special lunch shared with his classmates.

**WHEREAS**, a combination of Thomas' leadership, love of athleticism and dedication to his learning and knowledge have led him to pursue a career in Sports Medicine/Athletics Training at Louisiana State University in Baton Rouge. Thomas has been honored to have the support of his family, community, teammates and classmates during his high school football career, with the especially meaningful support of his mother, Ms. Kamisha Jackson and older sister Christina Thomas;

**NOW, THEREFORE, BE IT RESOLVED** by the Caddo Parish Commission in legal and regular session this 17<sup>th</sup> day of February, 2022, that it does hereby extend its most sincere and heartfelt expressions of congratulation and appreciation to **Mr. Christopher Thomas, Jr.** for his praiseworthy achievements and for representing Caddo Parish with such admirable strength and dedication to excellence while playing in the Dream All-American Bowl.

**BE IT FURTHER RESOLVED**, that the Caddo Parish Commission asks all citizens to join in celebrating Mr. Thomas' accomplishment and wishes him continued success in all his future endeavors.

**ATTEST:**

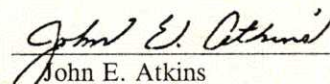

  
John E. Atkins  
President

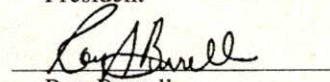
  
Roy Burrell  
Vice President

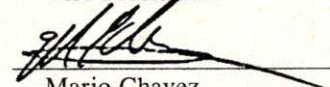
  
Mario Chavez  
District 10

  
Jeff Everson  
Commission Clerk

INTER-OFFICE CORRESPONDENCE

PARISH OF CADDO

ADMINISTRATION REPORT

DATE: FEBRUARY 14, 2022

TO: CADDO PARISH COMMISSION

FROM: ADMINISTRATION

---

INFORMATION

- 1.) Monument Relocation Update
- 2.) U.S. Treasury Emergency Rental Assistance Program
- 3.) Juvenile Detention
- 4.) Covid-19 Infection Data
- 5.) Facebook Update

**ORDINANCE NO. 6191 OF 2022**

BY THE CADDO PARISH COMMISSION:

**AN ORDINANCE AMENDING THE BUDGET OF ESTIMATED REVENUES AND EXPENDITURES FOR THE RIVERBOAT FUND AND OIL AND GAS FUND IN THE AMOUNT OF \$10,000 TO PROVIDE AN APPROPRIATION FOR THE LOUISIANA ADVOCATES FOR IMMIGRANTS IN DETENTION ASSOCIATED WITH THE HIGHLAND CENTER AND TO OTHERWISE PROVIDE WITH RESPECT THERETO**

WHEREAS, the Highland Center works with Louisiana Advocates for Immigrants in Detention (LA-AID); and

WHEREAS, LA-AID is an organization of volunteers who became active in the fall of 2019 in response to the burgeoning population of asylum seekers being held in Immigration and Customs Enforcement detention centers in rural Louisiana; and

WHEREAS, in the past 5 years, Louisiana went from having 1 immigration detention center to having 8 large detention centers ; and

WHEREAS, the Shreveport-based chapter of LA-AID, the only non-profit in Louisiana supporting post-release assistance, has been actively rescuing individuals who need safe transportation assistance from these facilities since February 2021; and

WHEREAS, the work of the LA-AID has been coordinated out of an expanded office affiliated with the Church for the Highlands where immigrants can cook meals, wash clothing, shower, use Internet and mobile phones, print boarding passes, and rest comfortably; and

WHEREAS, LA-AID is led by two unpaid, full-time volunteers and many additional volunteers from church congregations across Caddo Parish; and

WHEREAS, the Caddo Parish Commission would like to amend the 2022 Riverboat Fund and Oil and Gas Fund Budgets to provide an appropriation of \$10,000 for LA-AID; and

NOW, THEREFORE, BE IT ORDAINED, by the Caddo Parish Commission in due, legal and regular session convened, that Budget of Estimated Revenues and Expenditures for the Riverboat Fund and Oil and Gas Fund for the year 2022 is hereby amended as follows:

	<u>Budget Increase (Decrease)</u>
<b><u>Riverboat Fund</u></b>	
NGO Appropriations	
LA-AID	\$10,000
Transfer from Oil and Gas Fund	\$10,000
<b><u>Oil and Gas Fund</u></b>	
Transfer to Riverboat Fund	\$10,000
Fund Balance	(\$10,000)

BE IT FURTHER ORDAINED, that if any provision or item of this ordinance or the application thereof is held invalid, such invalidity shall not affect other provisions, items or applications which can be given effect without the invalid provisions, items or applications, and to this end the provisions of this ordinance are hereby declared severable.

BE IT FURTHER ORDAINED, that this ordinance shall take effect upon adoption.

BE IT FURTHER ORDAINED, that all ordinances or parts thereof in conflict herewith are hereby repealed.

Approved as to legal form:

\_\_\_\_\_  
Parish Attorney

\_\_\_\_\_  
Date

**ORDINANCE AND RESOLUTION AUTHORIZATION FORM**

**CADDO PARISH COMMISSION**

**TITLE**

ORDINANCE AMENDING THE 2022 BUDGET OF ESTIMATED REVENUES AND EXPENDITURES FOR THE RIVERBOAT FUND AND OIL AND GAS FUND

**(Ordinance No. 6191 of 2022)**

**ORIGINATING DEPARTMENT: Commissioner John Paul Young**

**BACKGROUND INFORMATION:** Amending the budget of Estimated Revenues and Expenditures for the Riverboat and Oil and Gas Fund to provide an appropriation of \$10,000 for LA-AID.

**Background and Capacity of Organization**

Louisiana Advocates for Immigrants in Detention (LA-AID) is an organization of volunteers who became active in the fall of 2019 in response to the burgeoning population of asylum seekers being held in Immigration and Customs Enforcement detention centers in rural Louisiana. In the past 5 years, Louisiana went from having 1 immigration detention center to having 8 large detention centers.

Nearly all the people transported to Louisiana by the federal government are healthy adults, affirmed to remain in the United States because of a credible fear of persecution or torture. Each person has been approved to continue his or her case in the court system while living with a sponsor (a family member or friend), who is a U.S. citizen or legal permanent resident.

With 16 partner organizations, LA-AID has filed a federal administrative complaint that the privately-owned detention facilities in Louisiana, who contract with ICE, have been releasing immigrants against federal agency policy into remote areas and in unsafe conditions without resources to contact their families or arrange customary transportation.

Detention facilities are required to provide immigrants in their care with free and safe transportation to the nearest public transport center (national bus station or airport) and allow each person to talk with their sponsor to make travel arrangements. However, it is well documented that these policies are not being followed in Louisiana and privately-owned facilities are in violation of ICE's Performance-Based National Detention Standards (PBNDS), established in 2011.

**Prior Experience of Organization, Joint Group Application and Collaboration, & Identify Needs and Gaps in Services in Neighborhood**

There are 3 detention centers within a 3-hour drive of Shreveport: Jena/LaSalle Detention Facility in Jena, LA; Winn Correctional Center in Winnfield, LA; and Jackson Parish Correctional Center in Jonesboro, LA. The Shreveport-based chapter of LA-AID has been actively rescuing individuals who need safe transportation assistance from these facilities since February 2021. While there are

many established, emergency-support immigration NGOs in “border states” such as Texas and Arizona, Louisiana does not have any similar nonprofits supporting similar post-release assistance.

Therefore, our volunteers receive notice each day if individuals will be released that same day in rural Louisiana and drive 4-6 hours round-trip to pick up the guest so that each immigrant will have safe transportation and accommodations as they travel through the nearest regional transportation hubs found in Caddo Parish.

Our volunteer-led organization purchases pre-paid phones so that guests can call their families and book travel arrangements. Volunteers provide translation services, assist with flights or bus tickets, and ensure that each person eats and has a safe place to spend a night. Volunteers drive guests to the airport each day before their flights and walk them to a TSA Agent.

**Extent of Neighborhood Involvement & Description of Project and Soundness of Project**

This work has been coordinated out of an expanded office affiliated with the Church for the Highlands where guests can cook meals, wash clothing, shower, use Internet and mobile phones, print boarding passes, and rest comfortably. The new nonprofit is led by two unpaid, full-time volunteers and many additional volunteers from church congregations across Caddo Parish. The team is also actively coordinating with their counterparts in other Louisiana cities.

Over 436 immigrants traveled through Caddo Parish between March and July 2021 and were assisted by LA-AID. Between July – December 2021, our volunteers drove 16,378 miles and helped 798 people from over 46 countries reunite with family and friends around the United States as they safely traveled through Caddo Parish.

While we are glad to help guests in need unite their families safely, hosting new and unexpected guests for weeks and weeks has also pushed the limits of our professional capacity and the generosity of our hosts. Support from the Parish of Caddo would help ensure that our organization is able to continue operating and meet the public safety crisis that has emerged in our region.

**KEY STAFF CONTACT:** Hayley Barnett

**AUTHORIZATION**

Department Head Hayley B. Barnett Date 1/26/2022

Legal \_\_\_\_\_ Date \_\_\_\_\_

Parish Administrator \_\_\_\_\_ Date \_\_\_\_\_



*PARISH OF CADDO, LOUISIANA*

*GUIDELINES FOR APPROPRIATION APPLICATIONS*

Name of Entity: Louisiana Advocates for Immigrants in Detention (LA-AID)

**Please review the following guidelines for funding and initial indicating you have read and understand each item prior to submitting an application:**

- FK 1. Appropriations are made on an annual basis; **receiving funding one year does not guarantee that the organization will receive funds in the same amount, or at all during the next year.**
- FK 2. Funds are appropriated for specific programs that an organization sponsors and **cannot be used for the day-to-day operating expenses of the organization (i.e. salaries, office expenses, rent).**
- FK 3. The program for which an appropriation is requested must provide services to unskilled poor, low-income persons, unemployed persons or students from those families; alternatively, the program must provide a measurable means of economic development for Caddo Parish.
- FK 4. Funds cannot be used for the following:
  - a. Capital purchases/improvements such as building repairs/renovations, playground equipment (even if for the parish-funded program) of an organization;
  - b. Equipment used in any other program other than the one the Parish is funding;
  - c. To benefit non-Caddo citizens.
- FK 5. Funds cannot be used directly or indirectly in any trade or business carried on by any person or entity other than Grantee.
- FK 6. An organization receiving monies through the Caddo Parish Commission's appropriation process must give two reports detailing the use of those funds: a report detailing the use of the funds from January 1<sup>st</sup> - June 30<sup>th</sup> of the appropriation year (due July 31<sup>st</sup>), and a report detailing the use of the funds from July 1<sup>st</sup> - December 31<sup>st</sup> of the appropriation year (due January 31<sup>st</sup> of the year following the appropriation). A subsequent appropriation application will **not** be considered if the July 31<sup>st</sup> report has not been timely submitted; an approved appropriation will **not** be funded if the January 31<sup>st</sup> report has not been timely submitted. These reports must include invoices, receipts cancelled checks and any other documents related to the expenditure of Parish funds, and the Parish reserves the right to audit all organization records related to the appropriation at any time.
- FK 7. No funds will be paid until all required reports have been received and approved by the Parish of Caddo.
- FK 8. Funds must be spent **in accordance with the provisions outlined in the Cooperative Endeavor Agreement (CEA)**. Listing items in the detailed budget does not make them eligible for reimbursement; the items must be covered in the CEA.

**SECTION I: INTRODUCTION AND FUNDING PURPOSE**

It is important that each section of this request be completed.

1. **Name of Entity:** Louisiana Advocates for Immigrants in Detention

**Commission District:** District 4

**Address:** 520 Olive Street

Shreveport, LA 71104

**Is this the address of the organization's headquarters?**  Yes  No

*If not, please list headquarter address:* \_\_\_\_\_

**Does your organization provide services in more than one commission district?**

Yes  No

*If yes please list other districts served and addresses (if available):*

**District** \_\_\_\_\_

**District** \_\_\_\_\_

**Address** \_\_\_\_\_

**Address** \_\_\_\_\_

**Contact Person:** Mr. / Mrs. / Ms. Frances Kelley

**Title:** Board Secretary

**Phone Number:** ( 318 ) 780-4138

**Fax:** (      ) \_\_\_\_\_

**Email:** frances.elizabeth.kelley@gmail.com

**Past Grant Recipient?**  Yes  No

2. **Purpose for which Parish funds would be used (Check one and give brief description):**

**Economic Development:**

**Education:**

**Social Welfare:**

Abate public safety and humanitarian crisis related to illegal implementation of federal laws on immigration impacting Caddo Parish

3. **Amount of this funding request:** \$10,000

4. **During what time period will the funds be used:** Jan. 1, 2022 through December 30, 2022

5. Are audited financial statements available?  Yes  No

Please furnish most recent financial statement period covered:

July 1, 2021 through December 30, 2021

6. Are you exempt from Federal Income Tax?  Yes  No

Under IRS Code Section: 501(c)(3)

7. Have you filed form 990 (Return of Organization Exempt from Income Tax)?  Yes  No

Date of last time filed: \_\_\_\_\_

8. Quarterly drawdowns are agreed to be acceptable:  Yes  No  
*(If not, please propose an alternate drawdown schedule and explain)*

9. Does the organization have any outstanding tax claims (City, Parish, State or Federal)?  
 Yes  No *(If so, please explain claim)*

10. Are you in good standing with the State of Louisiana?  Yes  No  
Please provide a copy of your Certificate of Good Standing.

N/A

11. Please attach any other information that you wish to submit in support of your application.

## **SECTION II: PROPOSAL NARRATIVE**

The proposal narrative must be formatted as outlined below. Proposals that are not submitted in the following format will not be reviewed. This section shall not exceed three pages, double spaced in 12-font. The application outline must address all of the following items below:

### **Background and Capacity of Organization**

Briefly describe your organization. This description should include the length of existence, the number of officers, members, and mission. Explain the organization's capacity to successfully implement the proposed project in a timely manner.

### **Prior Experience of Organization**

Description of past completed projects involving community and Parish activities in the past three (3) years, including the type of project, project location, and how it benefited the Parish.

### **Extent of Neighborhood Involvement**

Describe the manner in which you will attract volunteers to your project. Describe how a significant number of people with diverse interests in the neighborhood will be involved in and benefit from this project.

### **Description of Project and Soundness of Project**

This summary should provide an overview of entire project(s), including project location and how this project will benefit the Parish. This project must be clearly understood, well planned, and ready to proceed.

### **Joint Group Application and Collaboration**

State whether your organization is submitting this application along with another Parish-based organization. Also, describe any partnerships that were formed or will be formed to plan and implement this project. Please include names of all partnerships, consultants and other organizations that Caddo Parish appropriations will fund with the amount of monies going to each.

### **Identify Needs and Gaps in Services in Neighborhood**

List the priority needs that the organization has identified in the neighborhood along with any gaps of services that have been noted.

## **Background and Capacity of Organization**

Louisiana Advocates for Immigrants in Detention (LA-AID) is an organization of volunteers who became active in the fall of 2019 in response to the burgeoning population of asylum seekers being held in Immigration and Customs Enforcement detention centers in rural Louisiana. In the past 5 years, Louisiana went from having 1 immigration detention center to having 8 large detention centers.

Many people transported to Louisiana by the federal government are adults, affirmed to remain in the United States because of a credible fear of persecution or torture. Each person has been approved to continue his or her case in the court system while living with a U.S. sponsor (a family member or friend).

With 16 partner organizations, LA-AID has filed a federal administrative complaint that the privately-owned detention facilities in Louisiana, who contract with ICE, have been releasing immigrants against federal agency policy into remote areas and in unsafe conditions without resources to contact their families or arrange customary transportation.

Detention facilities are required to provide immigrants in their care with free and safe transportation to the nearest public transport center (national bus station or airport) and allow each person to talk with their sponsor to make travel arrangements. However, it is well documented that these policies are not being followed in Louisiana and privately-owned facilities are in violation of ICE's Performance-Based National Detention Standards (PBNDS), established in 2011.

## **Prior Experience of Organization, Joint Group Application and Collaboration, & Identify Needs and Gaps in Services in Neighborhood**

There are 3 detention centers within a 3-hour drive of Shreveport: Jena/LaSalle Detention Facility in Jena, LA; Winn Correctional Center in Winnfield, LA; and Jackson Parish Correctional Center in Jonesboro, LA. The Shreveport-based chapter of LA-AID has been actively assisting individuals who need safe transportation from these facilities since February 2021. While there are many established, emergency-support immigration NGOs in "border states" such as Texas and Arizona, Louisiana does not have any similar nonprofits supporting similar post-release assistance.

Therefore, our volunteers receive notice each day if individuals will be released that same day in rural Louisiana and drive 4-6 hours round-trip to pick up the guest so that each immigrant will have safe transportation and accommodations as they travel through the regional transportation hubs found in Caddo Parish.

Our volunteer-led organization purchases pre-paid phones so that guests can call their families and book travel arrangements. Volunteers provide translation services, assist with flights or bus tickets, and ensure that each person eats and has a safe place to spend a night. Volunteers drive guests to the airport each day before their flights and walk them to a TSA Agent.

## **Extent of Neighborhood Involvement & Description of Project and Soundness of Project**

This work has been coordinated out of an expanded office affiliated with the Church for the Highlands where guests can cook meals, wash clothing, shower, use Internet and mobile phones, print boarding passes, and rest comfortably. The new nonprofit is led by two unpaid, full-time volunteers and many additional volunteers from church congregations across Caddo Parish. The team is also actively coordinating with their counterparts in other Louisiana cities.

Over 436 immigrants traveled through Caddo Parish between March and July 2021 and were assisted by LA-AID. Between July – December 2021, our volunteers drove 16,378 miles and helped 798 people from over 46 countries reunite with family and friends around the United States as they safely traveled through Caddo Parish.

While we are glad to help guests in need unite their families safely, hosting new and unexpected guests for weeks and weeks has also pushed the limits of our professional capacity and the generosity of our hosts. Support from the Parish of Caddo would help ensure that our organization is able to continue operating and meet the public safety crisis that has emerged in our region.

**ATTACHMENT A: CONTACT INFORMATION**

List the names, addresses, and Commission District (if applicable) of all board members.

<b>Name</b>	<b>Address</b>	<b>Commission District</b>
Frances Kelley	935 Linden Street Shreveport, LA 71104	4
Michelle LaFleur MacFadyen	107 Silverbell Parkway Lafayette, LA 70508	NA
Leslie Elliottsmith	6006 Navaho Trail Alexandria, LA 71301	NA

## ATTACHMENT B: PROJECT TIMELINE

**This summary should provide a written timeline to show benchmarks for project implementation and completion. Describe any recent, relevant and successfully demonstrated experience in undertaking similar projects. Include the knowledge and experience of the proposed day-to-day project team leader.**

Building on the past year of effective work, from January 1, 2022, to June 30, 2022, the Caddo-based chapter of the nonprofit LA-AID will ensure that asylum seekers- who are approved to travel through Caddo Parish from the nearest three Immigrant and Customs Enforcement detention centers to their families and friends across the United States- will have safe and professional assistance with translation, transportation, and essential needs as the federal agency improves their processes and the state-wide agency builds capacity to accommodate and support this new, regional humanitarian and public safety crisis.

**ATTACHMENT C:**

**Caddo Parish Appropriation BUDGET FORM**

Please provide detailed explanation of each line item.

Organization Name \_\_\_\_\_

LA-AID \_\_\_\_\_

Budget Year 2022

**Funding Amount**

<b>Line Item Object</b>	<b>Parish Amount</b>	<b>Other Amounts*</b>	<b>In-Kind (Including Food Bank)</b>	<b>Total</b>
Facility		\$20,790.00		\$20,790.00
Personnel			\$55,000.00	\$55,000.00
Mileage		\$2,100.00		\$2,100.00
Meals	\$5,494.00	\$2,640.00		\$8,170.00
Telecommunications	\$1,400.00	\$676.00		\$2,076.00
Supplies	\$920.00		\$2,280.00	\$3,200.00
Repairs	\$1,750.00	\$1,850.00		\$3,600.00
Airport Parking		\$540.00		\$540.00
Insurance	\$436.00	\$514.00		\$950.00
<b>Total</b>	\$10,000.00	\$29,110.00	\$57,280.00	\$96,426.00

\*Please provide a detailed listing of the funding source for other amounts.

\*If funding tuition for low-income persons to attend your program, please provide a detailed listing of the items covered by the tuition.



Department of the Treasury  
Internal Revenue Service  
Tax Exempt and Government Entities  
P.O. Box 2508  
Cincinnati, OH 45201

LOUISIANA ADVOCATES FOR  
IMMIGRANTS IN DETENTION  
262 WILKINSON STREET  
SHREVEPORT, LA 71104

**Date:**  
01/07/2022  
**Employer ID number:**  
87-2935596  
**Person to contact:**  
Name: Customer Service  
ID number: 31954  
Telephone: (877) 829-5500  
**Accounting period ending:**  
December 31  
**Public charity status:**  
170(b)(1)(A)(vi)  
**Form 990 / 990-EZ / 990-N required:**  
Yes  
**Effective date of exemption:**  
September 28, 2021  
**Contribution deductibility:**  
Yes  
**Addendum applies:**  
No  
**DLN:**  
26053691002261

Dear Applicant:

We're pleased to tell you we determined you're exempt from federal income tax under Internal Revenue Code (IRC) Section 501(c)(3). Donors can deduct contributions they make to you under IRC Section 170. You're also qualified to receive tax deductible bequests, devises, transfers or gifts under Section 2055, 2106, or 2522. This letter could help resolve questions on your exempt status. Please keep it for your records.

Organizations exempt under IRC Section 501(c)(3) are further classified as either public charities or private foundations. We determined you're a public charity under the IRC Section listed at the top of this letter.

If we indicated at the top of this letter that you're required to file Form 990/990-EZ/990-N, our records show you're required to file an annual information return (Form 990 or Form 990-EZ) or electronic notice (Form 990-N, the e-Postcard). If you don't file a required return or notice for three consecutive years, your exempt status will be automatically revoked.

If we indicated at the top of this letter that an addendum applies, the enclosed addendum is an integral part of this letter.

For important information about your responsibilities as a tax-exempt organization, go to [www.irs.gov/charities](http://www.irs.gov/charities). Enter "4221-PC" in the search bar to view Publication 4221-PC, Compliance Guide for 501(c)(3) Public Charities, which describes your recordkeeping, reporting, and disclosure requirements.

Sincerely,

Stephen A. Martin  
Director, Exempt Organizations  
Rulings and Agreements

**AFFIDAVIT**

I hereby certify that the information provided in this application and all accompanying forms is true and accurate as of the date of completion.

**Signature:**

Frances Kelley

**Title:**

Board Secretary

**Date:**

1/26/22



(https://www.sos.la.gov/Pages/default.aspx)

**Search for Louisiana Business Filings**

[Buy Certificates and Certified Copies](#) [Subscribe to Electronic Notification](#) [Print Detailed Record](#)

<b>Name</b>	<b>Type</b>	<b>City</b>	<b>Status</b>
LOUISIANA ADVOCATES FOR IMMIGRANTS IN DETENTION	Non-Profit Corporation	SHREVEPORT	Active

**Previous Names**

**Business:** LOUISIANA ADVOCATES FOR IMMIGRANTS IN DETENTION  
**Charter Number:** 44613657N  
**Registration Date:** 10/1/2021

**Domicile Address**

262 WILKINSON STREET  
 SHREVEPORT, LA 71104

**Mailing Address**

262 WILKINSON STREET  
 SHREVEPORT, LA 71104

**Status**

**Status:** Active  
**Annual Report Status:** In Good Standing  
**File Date:** 10/1/2021  
**Last Report Filed:** N/A  
**Type:** Non-Profit Corporation

**Registered Agent(s)**

<b>Agent:</b>	MADISON POCHE
<b>Address 1:</b>	262 WILKINSON STREET
<b>City, State, Zip:</b>	SHREVEPORT, LA 71104
<b>Appointment Date:</b>	10/1/2021

**Officer(s)**

Additional Officers: No

<b>Officer:</b>	FRANCES KELLEY
<b>Title:</b>	Director
<b>Address 1:</b>	935 LINDEN STREET
<b>City, State, Zip:</b>	SHREVEPORT, LA 71104
<b>Officer:</b>	MICHELLE LAFLEUR MACFADYEN
<b>Title:</b>	Director
<b>Address 1:</b>	107 SILVERBELL PARKWAY
<b>City, State, Zip:</b>	LAFAYETTE, LA 70508
<b>Officer:</b>	LESLIE ELLIOTTSMITH
<b>Title:</b>	Director
<b>Address 1:</b>	6006 NAVAHO TRAIL
<b>City, State, Zip:</b>	ALEXANDRIA, LA 71301

**Amendments on File**

No Amendments on file

[Back to Search Results](#) [New Search](#) [View Shopping Cart](#)

GET HELP

# PARISH OF CADDO, LOUISIANA

## GUIDELINES FOR APPROPRIATION APPLICATIONS

Name of Entity: Louisiana Advocates for Immigrants in Detention (LA-AID)

**Please review the following guidelines for funding and initial indicating you have read and understand each item prior to submitting an application:**

- FK 1. Appropriations are made on an annual basis; **receiving funding one year does not guarantee that the organization will receive funds in the same amount, or at all during the next year.**
- FK 2. Funds are appropriated for specific programs that an organization sponsors and **cannot be used for the day-to-day operating expenses of the organization (i.e. salaries, office expenses, rent).**
- FK 3. The program for which an appropriation is requested must provide services to unskilled poor, low-income persons, unemployed persons or students from those families; alternatively, the program must provide a measurable means of economic development for Caddo Parish.
- FK 4. Funds cannot be used for the following:
  - a. Capital purchases/improvements such as building repairs/renovations, playground equipment (even if for the parish-funded program) of an organization;
  - b. Equipment used in any other program other than the one the Parish is funding;
  - c. To benefit non-Caddo citizens.
- FK 5. Funds cannot be used directly or indirectly in any trade or business carried on by any person or entity other than Grantee.
- FK 6. An organization receiving monies through the Caddo Parish Commission's appropriation process must give two reports detailing the use of those funds: a report detailing the use of the funds from January 1<sup>st</sup> - June 30<sup>th</sup> of the appropriation year (due July 31<sup>st</sup>), and a report detailing the use of the funds from July 1<sup>st</sup> - December 31<sup>st</sup> of the appropriation year (due January 31<sup>st</sup> of the year following the appropriation). A subsequent appropriation application will **not** be considered if the July 31<sup>st</sup> report has not been timely submitted; an approved appropriation will **not** be funded if the January 31<sup>st</sup> report has not been timely submitted. These reports must include invoices, receipts cancelled checks and any other documents related to the expenditure of Parish funds, and the Parish reserves the right to audit all organization records related to the appropriation at any time.
- FK 7. No funds will be paid until all required reports have been received and approved by the Parish of Caddo.
- FK 8. Funds must be spent **in accordance with the provisions outlined in the Cooperative Endeavor Agreement (CEA)**. Listing items in the detailed budget does not make them eligible for reimbursement; the items must be covered in the CEA.

# SECTION I: INTRODUCTION AND FUNDING PURPOSE

It is important that each section of this request be completed.

1. Name of Entity: Louisiana Advocates for Immigrants in Detention

Commission District: District 4

Address: 520 Olive Street

Shreveport, LA 71104

Is this the address of the organization's headquarters?  Yes  No

If not, please list headquarter address: \_\_\_\_\_

Does your organization provide services in more than one commission district?

Yes  No

If yes please list other districts served and addresses (if available):

District \_\_\_\_\_

District \_\_\_\_\_

Address \_\_\_\_\_

Address \_\_\_\_\_

Contact Person: Mr. / Mrs. / Ms. Frances Kelley

Title: Board Secretary

Phone Number: ( 318 ) 780-4138 Fax: ( \_\_\_\_\_ ) \_\_\_\_\_

Email: frances.elizabeth.kelley@gmail.com Past Grant Recipient?  Yes  No

2. Purpose for which Parish funds would be used (Check one and give brief description):

Economic Development:

Education:

Social Welfare:

Abate public safety and humanitarian crisis related to illegal implementation of federal laws on immigration impacting Caddo Parish

3. Amount of this funding request: \$10,000

4. During what time period will the funds be used: Jan. 1, 2022 through December 30, 2022

5. Are audited financial statements available?  Yes  No

Please furnish most recent financial statement period covered:

July 1, 2021 through December 30, 2021

6. Are you exempt from Federal Income Tax?  Yes  No

Under IRS Code Section: 501(c)(3)

7. Have you filed form 990 (Return of Organization Exempt from Income Tax)?  Yes  No

Date of last time filed: \_\_\_\_\_

8. Quarterly drawdowns are agreed to be acceptable:  Yes  No

*(If not, please propose an alternate drawdown schedule and explain)*

9. Does the organization have any outstanding tax claims (City, Parish, State or Federal)?

Yes  No *(If so, please explain claim)*

10. Are you in good standing with the State of Louisiana?  Yes  No

Please provide a copy of your Certificate of Good Standing.

N/A

11. Please attach any other information that you wish to submit in support of your application.

## SECTION II: PROPOSAL NARRATIVE

The proposal narrative must be formatted as outlined below. Proposals that are not submitted in the following format will not be reviewed. This section shall not exceed three pages, double spaced in 12-font. The application outline must address all of the following items below:

### **Background and Capacity of Organization**

Briefly describe your organization. This description should include the length of existence, the number of officers, members, and mission. Explain the organization's capacity to successfully implement the proposed project in a timely manner.

### **Prior Experience of Organization**

Description of past completed projects involving community and Parish activities in the past three (3) years, including the type of project, project location, and how it benefited the Parish.

### **Extent of Neighborhood Involvement**

Describe the manner in which you will attract volunteers to your project. Describe how a significant number of people with diverse interests in the neighborhood will be involved in and benefit from this project.

### **Description of Project and Soundness of Project**

This summary should provide an overview of entire project(s), including project location and how this project will benefit the Parish. This project must be clearly understood, well planned, and ready to proceed.

### **Joint Group Application and Collaboration**

State whether your organization is submitting this application along with another Parish-based organization. Also, describe any partnerships that were formed or will be formed to plan and implement this project. Please include names of all partnerships, consultants and other organizations that Caddo Parish appropriations will fund with the amount of monies going to each.

### **Identify Needs and Gaps in Services in Neighborhood**

List the priority needs that the organization has identified in the neighborhood along with any gaps of services that have been noted.

## ATTACHMENT A: CONTACT INFORMATION

List the names, addresses, and Commission District (if applicable) of all board members.

Name	Address	Commission District
Frances Kelley	935 Linden Street Shreveport, LA 71104	4
Michelle LaFleur MacFadyen	107 Silverbell Parkway Lafayette, LA 70508	NA
Leslie Elliottsmith	6006 Navaho Trail Alexandria, LA 71301	NA

## ATTACHMENT B: PROJECT TIMELINE

**This summary should provide a written timeline to show benchmarks for project implementation and completion. Describe any recent, relevant and successfully demonstrated experience in undertaking similar projects. Include the knowledge and experience of the proposed day-to-day project team leader.**

Building on the past year of effective work, from January 1, 2022, to June 30, 2022, the Caddo-based chapter of the nonprofit LA-AID will ensure that asylum seekers- who are approved to travel through Caddo Parish from the nearest three Immigrant and Customs Enforcement detention centers to their families and friends across the United States- will have safe and professional assistance with translation, transportation, and essential needs as the federal agency improves their processes and the state-wide agency builds capacity to accommodate and support this new, regional humanitarian and public safety crisis.

**ATTACHMENT C:**  
**Caddo Parish Appropriation BUDGET FORM**  
Please provide detailed explanation of each line item.

Organization Name LA-AID

Budget Year 2022

Line Item Object	Funding Amount			Total
	Parish Amount	Other Amounts*	In-Kind (Including Food Bank)	
Facility		\$20,790.00		\$20,790.00
Personnel			\$55,000.00	\$55,000.00
Mileage		\$2,100.00		\$2,100.00
Meals	\$5,494.00	\$2,640.00		\$8,170.00
Telecommunications	\$1,400.00	\$676.00		\$2,076.00
Supplies	\$920.00		\$2,280.00	\$3,200.00
Repairs	\$1,750.00	\$1,850.00		\$3,600.00
Airport Parking		\$540.00		\$540.00
Insurance	\$436.00	\$514.00		\$950.00
<b>Total</b>	\$10,000.00	\$29,110.00	\$57,280.00	\$96,426.00

\*Please provide a detailed listing of the funding source for other amounts.

\*If funding tuition for low-income persons to attend your program, please provide a detailed listing of the items covered by the tuition.

**AFFIDAVIT**

**I hereby certify that the information provided in this application and all accompanying forms is true and accurate as of the date of completion.**

**Signature:**

\_\_\_\_\_

**Title:**

\_\_\_\_\_

**Date:**

\_\_\_\_\_

## CHECKLIST OF REQUIRED DOCUMENTS

### Guidelines For Appropriation Applications

Application

Proposal Narrative (See application outline on page 3)

Attachment A

Attachment B

Attachment C

Copy of current IRS 501(c)(3) tax exempt statement indicating that you are not a private foundation and an explanation of any changes in your IRS status (if applicable)

Affidavit

Copy of Certificate of Good Standing with State of Louisiana

**ORDINANCE NO. 6193 OF 2022**

BY THE CADDO PARISH COMMISSION:

**AN ORDINANCE CREATING THE I-49 NORTH CORRIDOR ECONOMIC DEVELOPMENT DISTRICT, STATE OF LOUISIANA;" DEFINING THE BOUNDARIES THEREOF FROM WHICH AREA LOCAL SALES TAX, PROPERTY TAX AND HOTEL OCCUPANCY TAX INCREMENTS WILL BE DETERMINED AND USED TO FINANCE ECONOMIC DEVELOPMENT PROJECTS IN ACCORDANCE WITH AND AS AUTHORIZED BY PART II OF CHAPTER 27 OF TITLE 33 OF THE LOUISIANA REVISED STATUTES OF 1950, AS AMENDED; AND PROVIDING FOR OTHER MATTERS IN CONNECTION WITH THE FOREGOING.**

**WHEREAS**, Part II, Chapter 27, Title 33 of the Louisiana Revised Statutes of 1950, as amended (La. R S. 33:9038.31, *et seq.*) (the "EDD Act") authorizes municipalities, parishes and certain other local governmental subdivisions to create economic development districts to carry out the purposes of the Act, which economic development districts are political subdivisions of the State of Louisiana and possess such power and authority and have such duties as provided by the Act and other law; and

**WHEREAS**, La. R S. 33:9038.39 further permits such economic development districts tolevy sales and use taxes and hotel occupancy taxes at a rate up to two percent (2%) for authorized purposes subsequent to the creation and establishment of the District; and

**WHEREAS**, La. R S. 33:9038.34(O) provides that this governing authority may create a special trust fund for the furtherance of economic development projects, as defined in the EDD Act, into which the incremental increases in such sales taxes, property taxes and hotel occupancy taxes shall be deposited and loaned, granted, donated, or pledged in furtherance of economic development projects as defined in the EDD Act; and

**WHEREAS**, the Parish of Caddo, State of Louisiana (the "Parish"), acting through this Parish Commission as its governing authority, desires to avail itself of the EDD Act to create an economic development district to be called The "I-49 North Corridor Economic Development District, State of Louisiana" (the "District"), in accordance with La. R S. 33:9038.32, from which District local and State sales tax increments and local property and hotel occupancy tax increments are expected to be determined and used to fund the Parish of Caddo Economic Development District Trust Fund; and

**WHEREAS**, in accordance with the Act, particularly La. R S. 33:9038.32(8) and La. R S. 33:9038.39, and Resolution No. ? adopted on ?, 2021, the Parish has given notice of its intention to create the District, and notice that it will hold a public hearing relative to the proposed creation of the District, including a description of the boundaries of the District and containing a map showing the boundaries of the District, which notice has been published two times in the Parish's official journal; and

**WHEREAS**, on this date, prior to the adoption of this ordinance, this governing authority did hold a public hearing pursuant to the aforesaid notice of intention, at which public hearing no objections were received with respect to the creation of the District.

**NOW, THEREFORE, THE COMMISSION FOR THE PARISH OF CADDO HEREBY ORDAINS:**

SECTION 1. All of the above "Whereas" clauses are adopted as a part of this ordinance.

SECTION 2. Creation of District. Under the authority of La. R S. 33:9038.32 there is hereby created an economic development district within the Parish, to be named the "I-49 North Corridor Economic Development District, State of Louisiana," having the geographical boundaries set forth in Exhibit A attached hereto, which Exhibit A is hereby incorporated in and made a part of this Ordinance, all pursuant to the EDD Act. As provided by the EDD Act, the governing body of the District shall be this Parish Commission. As provided by the EDD Act, the District shall be a political subdivision of the State of Louisiana and shall possess such powers and authority and have such duties as provided in the EDD Act and other law.

SECTION 3. Creation of Trust Fund. Under the authority of La. RS. 33:9038.34(O), there is hereby created a special trust fund, to be named the "Parish of Caddo Economic Development District Trust Fund" (the "Trust Fund") the purpose of which will be to fund economic development projects selected by the District in the manner provided by the EDD Act. The Trust Fund shall be established by the Director of Finance of the Parish and maintained as a separate fund, apart from other funds and accounts of the Parish or other entities, and shall be used strictly for the purposes set forth herein and in the EDD Act.

SECTION 4. Authorization of Officers. The Parish Administrator is hereby authorized, empowered and directed to do any and all things necessary and incidental to carry out the provisions of this ordinance.

SECTION 5. Severability. If any provision of this ordinance shall be held to be illegal or invalid, such illegality or invalidity shall not affect any other provision of this ordinance, but this ordinance shall be construed and enforced as if such illegal or invalid provisions had not been contained herein. Any constitutional or statutory provision enacted after the date of this ordinance which validates or makes legal any provision of this ordinance which would not otherwise be valid or legal, shall be deemed to apply to this ordinance.

**BE IT FURTHER ORDAINED**, that this ordinance, shall become effective ten (10) days after publication.

**BE IT FURTHER ORDAINED**, that all ordinances or parts thereof in conflict herewith are hereby repealed.

Approved as to legal form:

---

Parish Attorney

## **EXHIBIT A to Creation Ordinance**

**BOUNDARIES AND MAP OF PROPOSED I-49 NORTH CORRIDOR  
ECONOMIC DEVELOPMENT DISTRICT, STATE OF LOUISIANA  
A CERTAIN TRACT OR PARCEL OF LAND SITUATED IN CADDO, PARISH,  
LOUISIANA AND BEING MORE PARTICULARLY DESCRIBED AS  
FOLLOWS:**

7.498 acres to be defined as from: That part of the Southeast Quarter (SE1/4) of Section Thirteen (13), Township Twenty-two (22) North, Range Fifteen (15) West, lying South of the North right of way line of the Hosston-Miller's Bluff Road and East of the West Bank of Kelly Bayou Canal and all of the South Half of the Southwest Quarter (S1/2 of SW1/4) of Section Thirteen (13), Township Twenty-two (22) North, Range Fifteen (15) West, lying East of the West bank of Kelly Bayou Canal

**ORDINANCE AND RESOLUTION FACT SHEET**

**CADDO PARISH COMMISSION**

<b>TITLE</b>	
Ordinance No. <u>6193</u> of 2022	
AN ORDINANCE CREATING THE I-49 NORTH CORRIDOR ECONOMIC DEVELOPMENT DISTRICT, STATE OF LOUISIANA;" DEFINING THE BOUNDARIES THEREOF FROM WHICH AREA LOCAL SALES TAX, PROPERTY TAX AND HOTEL OCCUPANCY TAX INCREMENTS WILL BE DETERMINED AND USED TO FINANCE ECONOMIC DEVELOPMENT PROJECTS IN ACCORDANCE WITH AND AS AUTHORIZED BY PART II OF CHAPTER 27 OF TITLE 33 OF THE LOUISIANA REVISED STATUTES OF 1950, AS AMENDED; AND PROVIDING FOR OTHER MATTERS IN CONNECTION WITH THE FOREGOING	
DATE: 1/28/2022	ORIGINATING DEPARTMENT: Legal for Commissioner Hopkins
<b>BACKGROUND INFORMATION</b>	
Commissioner Hopkins has requested an ordinance be prepared with boundaries that conform to the boundaries in the notice of intent resolution appearing on the January 31 <sup>st</sup> work session agenda. This property is a truck stop and travel center for which the IDB is also doing a PILOT lease. The TIF District boundaries will only cover the truck stop and travel center property.	
<b>FINANCIAL IMPACT AND SOURCE OF FUNDING</b>	
None	
<b>EFFECT(S) OF PROPOSED ACTION</b>	
Passage of the ordinance will result in the creation of the TIF District; failure to pass it will result in the TIF District not being created.	
<b>ALTERNATIVES/STAFF RECOMMENDATION</b>	
Staff has no recommendation.	
<b>KEY STAFF CONTACT</b>	
Donna Frazier, Parish Attorney	
<b>COORDINATION</b>	
Department Head	(Initial) <i>DF</i>
Parish Administrator/CEO	(Initial) <i>DF</i>

**ORDINANCE NO. 6191 OF 2022**

BY THE CADDO PARISH COMMISSION:

**AN ORDINANCE AMENDING THE BUDGET OF ESTIMATED REVENUES AND EXPENDITURES FOR THE RIVERBOAT FUND AND OIL AND GAS FUND IN THE AMOUNT OF \$10,000 TO PROVIDE AN APPROPRIATION FOR THE LOUISIANA ADVOCATES FOR IMMIGRANTS IN DETENTION ASSOCIATED WITH THE HIGHLAND CENTER AND TO OTHERWISE PROVIDE WITH RESPECT THERETO**

WHEREAS, the Highland Center works with Louisiana Advocates for Immigrants in Detention (LA-AID); and

WHEREAS, LA-AID is an organization of volunteers who became active in the fall of 2019 in response to the burgeoning population of asylum seekers being held in Immigration and Customs Enforcement detention centers in rural Louisiana; and

WHEREAS, in the past 5 years, Louisiana went from having 1 immigration detention center to having 8 large detention centers ; and

WHEREAS, the Shreveport-based chapter of LA-AID, the only non-profit in Louisiana supporting post-release assistance, has been actively rescuing individuals who need safe transportation assistance from these facilities since February 2021; and

WHEREAS, the work of the LA-AID has been coordinated out of an expanded office affiliated with the Church for the Highlands where immigrants can cook meals, wash clothing, shower, use Internet and mobile phones, print boarding passes, and rest comfortably; and

WHEREAS, LA-AID is led by two unpaid, full-time volunteers and many additional volunteers from church congregations across Caddo Parish; and

WHEREAS, the Caddo Parish Commission would like to amend the 2022 Riverboat Fund and Oil and Gas Fund Budgets to provide an appropriation of \$10,000 for LA-AID; and

NOW, THEREFORE, BE IT ORDAINED, by the Caddo Parish Commission in due, legal and regular session convened, that Budget of Estimated Revenues and Expenditures for the Riverboat Fund and Oil and Gas Fund for the year 2022 is hereby amended as follows:

	<u>Budget Increase (Decrease)</u>
<b><u>Riverboat Fund</u></b>	
NGO Appropriations	
LA-AID	\$10,000
Transfer from Oil and Gas Fund	\$10,000
<b><u>Oil and Gas Fund</u></b>	
Transfer to Riverboat Fund	\$10,000
Fund Balance	(\$10,000)

BE IT FURTHER ORDAINED, that if any provision or item of this ordinance or the application thereof is held invalid, such invalidity shall not affect other provisions, items or applications which can be given effect without the invalid provisions, items or applications, and to this end the provisions of this ordinance are hereby declared severable.

BE IT FURTHER ORDAINED, that this ordinance shall take effect upon adoption.

BE IT FURTHER ORDAINED, that all ordinances or parts thereof in conflict herewith are hereby repealed.

Approved as to legal form:

\_\_\_\_\_  
Parish Attorney

\_\_\_\_\_  
Date

**ORDINANCE AND RESOLUTION AUTHORIZATION FORM**

**CADDO PARISH COMMISSION**

**TITLE**

ORDINANCE AMENDING THE 2022 BUDGET OF ESTIMATED REVENUES AND EXPENDITURES FOR THE RIVERBOAT FUND AND OIL AND GAS FUND

**(Ordinance No. 6191 of 2022)**

**ORIGINATING DEPARTMENT: Commissioner John Paul Young**

**BACKGROUND INFORMATION:** Amending the budget of Estimated Revenues and Expenditures for the Riverboat and Oil and Gas Fund to provide an appropriation of \$10,000 for LA-AID.

**Background and Capacity of Organization**

Louisiana Advocates for Immigrants in Detention (LA-AID) is an organization of volunteers who became active in the fall of 2019 in response to the burgeoning population of asylum seekers being held in Immigration and Customs Enforcement detention centers in rural Louisiana. In the past 5 years, Louisiana went from having 1 immigration detention center to having 8 large detention centers.

Nearly all the people transported to Louisiana by the federal government are healthy adults, affirmed to remain in the United States because of a credible fear of persecution or torture. Each person has been approved to continue his or her case in the court system while living with a sponsor (a family member or friend), who is a U.S. citizen or legal permanent resident.

With 16 partner organizations, LA-AID has filed a federal administrative complaint that the privately-owned detention facilities in Louisiana, who contract with ICE, have been releasing immigrants against federal agency policy into remote areas and in unsafe conditions without resources to contact their families or arrange customary transportation.

Detention facilities are required to provide immigrants in their care with free and safe transportation to the nearest public transport center (national bus station or airport) and allow each person to talk with their sponsor to make travel arrangements. However, it is well documented that these policies are not being followed in Louisiana and privately-owned facilities are in violation of ICE's Performance-Based National Detention Standards (PBNDS), established in 2011.

**Prior Experience of Organization, Joint Group Application and Collaboration, & Identify Needs and Gaps in Services in Neighborhood**

There are 3 detention centers within a 3-hour drive of Shreveport: Jena/LaSalle Detention Facility in Jena, LA; Winn Correctional Center in Winnfield, LA; and Jackson Parish Correctional Center in Jonesboro, LA. The Shreveport-based chapter of LA-AID has been actively rescuing individuals who need safe transportation assistance from these facilities since February 2021. While there are

many established, emergency-support immigration NGOs in “border states” such as Texas and Arizona, Louisiana does not have any similar nonprofits supporting similar post-release assistance.

Therefore, our volunteers receive notice each day if individuals will be released that same day in rural Louisiana and drive 4-6 hours round-trip to pick up the guest so that each immigrant will have safe transportation and accommodations as they travel through the nearest regional transportation hubs found in Caddo Parish.

Our volunteer-led organization purchases pre-paid phones so that guests can call their families and book travel arrangements. Volunteers provide translation services, assist with flights or bus tickets, and ensure that each person eats and has a safe place to spend a night. Volunteers drive guests to the airport each day before their flights and walk them to a TSA Agent.

**Extent of Neighborhood Involvement & Description of Project and Soundness of Project**

This work has been coordinated out of an expanded office affiliated with the Church for the Highlands where guests can cook meals, wash clothing, shower, use Internet and mobile phones, print boarding passes, and rest comfortably. The new nonprofit is led by two unpaid, full-time volunteers and many additional volunteers from church congregations across Caddo Parish. The team is also actively coordinating with their counterparts in other Louisiana cities.

Over 436 immigrants traveled through Caddo Parish between March and July 2021 and were assisted by LA-AID. Between July – December 2021, our volunteers drove 16,378 miles and helped 798 people from over 46 countries reunite with family and friends around the United States as they safely traveled through Caddo Parish.

While we are glad to help guests in need unite their families safely, hosting new and unexpected guests for weeks and weeks has also pushed the limits of our professional capacity and the generosity of our hosts. Support from the Parish of Caddo would help ensure that our organization is able to continue operating and meet the public safety crisis that has emerged in our region.

**KEY STAFF CONTACT:** Hayley Barnett

**AUTHORIZATION**

Department Head Hayley Barnett Date 1/26/2022

Legal \_\_\_\_\_ Date \_\_\_\_\_

Parish Administrator \_\_\_\_\_ Date \_\_\_\_\_



*PARISH OF CADDO, LOUISIANA*

*GUIDELINES FOR APPROPRIATION APPLICATIONS*

Name of Entity: Louisiana Advocates for Immigrants in Detention (LA-AID)

**Please review the following guidelines for funding and initial indicating you have read and understand each item prior to submitting an application:**

- FK 1. Appropriations are made on an annual basis; **receiving funding one year does not guarantee that the organization will receive funds in the same amount, or at all during the next year.**
- FK 2. Funds are appropriated for specific programs that an organization sponsors and **cannot be used for the day-to-day operating expenses of the organization (i.e. salaries, office expenses, rent).**
- FK 3. The program for which an appropriation is requested must provide services to unskilled poor, low-income persons, unemployed persons or students from those families; alternatively, the program must provide a measurable means of economic development for Caddo Parish.
- FK 4. Funds cannot be used for the following:
  - a. Capital purchases/improvements such as building repairs/renovations, playground equipment (even if for the parish-funded program) of an organization;
  - b. Equipment used in any other program other than the one the Parish is funding;
  - c. To benefit non-Caddo citizens.
- FK 5. Funds cannot be used directly or indirectly in any trade or business carried on by any person or entity other than Grantee.
- FK 6. An organization receiving monies through the Caddo Parish Commission's appropriation process must give two reports detailing the use of those funds: a report detailing the use of the funds from January 1<sup>st</sup> - June 30<sup>th</sup> of the appropriation year (due July 31<sup>st</sup>), and a report detailing the use of the funds from July 1<sup>st</sup> - December 31<sup>st</sup> of the appropriation year (due January 31<sup>st</sup> of the year following the appropriation). A subsequent appropriation application will **not** be considered if the July 31<sup>st</sup> report has not been timely submitted; an approved appropriation will **not** be funded if the January 31<sup>st</sup> report has not been timely submitted. These reports must include invoices, receipts cancelled checks and any other documents related to the expenditure of Parish funds, and the Parish reserves the right to audit all organization records related to the appropriation at any time.
- FK 7. No funds will be paid until all required reports have been received and approved by the Parish of Caddo.
- FK 8. Funds must be spent **in accordance with the provisions outlined in the Cooperative Endeavor Agreement (CEA)**. Listing items in the detailed budget does not make them eligible for reimbursement; the items must be covered in the CEA.

# SECTION I: INTRODUCTION AND FUNDING PURPOSE

It is important that each section of this request be completed.

1. **Name of Entity:** Louisiana Advocates for Immigrants in Detention

**Commission District:** District 4

**Address:** 520 Olive Street

Shreveport, LA 71104

**Is this the address of the organization's headquarters?**  Yes  No

*If not, please list headquarter address:* \_\_\_\_\_

**Does your organization provide services in more than one commission district?**

Yes  No

*If yes please list other districts served and addresses (if available):*

**District** \_\_\_\_\_

**District** \_\_\_\_\_

**Address** \_\_\_\_\_

**Address** \_\_\_\_\_

**Contact Person:** Mr. / Mrs. / Ms. Frances Kelley

**Title:** Board Secretary

**Phone Number:** ( 318 ) 780-4138

**Fax:** ( \_\_\_\_\_ ) \_\_\_\_\_

**Email:** frances.elizabeth.kelley@gmail.com

**Past Grant Recipient?**  Yes  No

2. **Purpose for which Parish funds would be used (Check one and give brief description):**

**Economic Development:**

**Education:**

**Social Welfare:**

Abate public safety and humanitarian crisis related to illegal implementation of federal laws on immigration impacting Caddo Parish

3. **Amount of this funding request:** \$10,000

4. **During what time period will the funds be used:** Jan. 1, 2022 through December 30, 2022

5. Are audited financial statements available?  Yes  No

Please furnish most recent financial statement period covered:

July 1, 2021 through December 30, 2021

6. Are you exempt from Federal Income Tax?  Yes  No

Under IRS Code Section: 501(c)(3)

7. Have you filed form 990 (Return of Organization Exempt from Income Tax)?  Yes  No

Date of last time filed: \_\_\_\_\_

8. Quarterly drawdowns are agreed to be acceptable:  Yes  No  
*(If not, please propose an alternate drawdown schedule and explain)*

9. Does the organization have any outstanding tax claims (City, Parish, State or Federal)?  
 Yes  No *(If so, please explain claim)*

10. Are you in good standing with the State of Louisiana?  Yes  No  
Please provide a copy of your Certificate of Good Standing.

N/A

11. Please attach any other information that you wish to submit in support of your application.

## **SECTION II: PROPOSAL NARRATIVE**

The proposal narrative must be formatted as outlined below. Proposals that are not submitted in the following format will not be reviewed. This section shall not exceed three pages, double spaced in 12-font. The application outline must address all of the following items below:

### **Background and Capacity of Organization**

Briefly describe your organization. This description should include the length of existence, the number of officers, members, and mission. Explain the organization's capacity to successfully implement the proposed project in a timely manner.

### **Prior Experience of Organization**

Description of past completed projects involving community and Parish activities in the past three (3) years, including the type of project, project location, and how it benefited the Parish.

### **Extent of Neighborhood Involvement**

Describe the manner in which you will attract volunteers to your project. Describe how a significant number of people with diverse interests in the neighborhood will be involved in and benefit from this project.

### **Description of Project and Soundness of Project**

This summary should provide an overview of entire project(s), including project location and how this project will benefit the Parish. This project must be clearly understood, well planned, and ready to proceed.

### **Joint Group Application and Collaboration**

State whether your organization is submitting this application along with another Parish-based organization. Also, describe any partnerships that were formed or will be formed to plan and implement this project. Please include names of all partnerships, consultants and other organizations that Caddo Parish appropriations will fund with the amount of monies going to each.

### **Identify Needs and Gaps in Services in Neighborhood**

List the priority needs that the organization has identified in the neighborhood along with any gaps of services that have been noted.

## **Background and Capacity of Organization**

Louisiana Advocates for Immigrants in Detention (LA-AID) is an organization of volunteers who became active in the fall of 2019 in response to the burgeoning population of asylum seekers being held in Immigration and Customs Enforcement detention centers in rural Louisiana. In the past 5 years, Louisiana went from having 1 immigration detention center to having 8 large detention centers.

Many people transported to Louisiana by the federal government are adults, affirmed to remain in the United States because of a credible fear of persecution or torture. Each person has been approved to continue his or her case in the court system while living with a U.S. sponsor (a family member or friend).

With 16 partner organizations, LA-AID has filed a federal administrative complaint that the privately-owned detention facilities in Louisiana, who contract with ICE, have been releasing immigrants against federal agency policy into remote areas and in unsafe conditions without resources to contact their families or arrange customary transportation.

Detention facilities are required to provide immigrants in their care with free and safe transportation to the nearest public transport center (national bus station or airport) and allow each person to talk with their sponsor to make travel arrangements. However, it is well documented that these policies are not being followed in Louisiana and privately-owned facilities are in violation of ICE's Performance-Based National Detention Standards (PBNDS), established in 2011.

## **Prior Experience of Organization, Joint Group Application and Collaboration, & Identify Needs and Gaps in Services in Neighborhood**

There are 3 detention centers within a 3-hour drive of Shreveport: Jena/LaSalle Detention Facility in Jena, LA; Winn Correctional Center in Winnfield, LA; and Jackson Parish Correctional Center in Jonesboro, LA. The Shreveport-based chapter of LA-AID has been actively assisting individuals who need safe transportation from these facilities since February 2021. While there are many established, emergency-support immigration NGOs in "border states" such as Texas and Arizona, Louisiana does not have any similar nonprofits supporting similar post-release assistance.

Therefore, our volunteers receive notice each day if individuals will be released that same day in rural Louisiana and drive 4-6 hours round-trip to pick up the guest so that each immigrant will have safe transportation and accommodations as they travel through the regional transportation hubs found in Caddo Parish.

Our volunteer-led organization purchases pre-paid phones so that guests can call their families and book travel arrangements. Volunteers provide translation services, assist with flights or bus tickets, and ensure that each person eats and has a safe place to spend a night. Volunteers drive guests to the airport each day before their flights and walk them to a TSA Agent.

## **Extent of Neighborhood Involvement & Description of Project and Soundness of Project**

This work has been coordinated out of an expanded office affiliated with the Church for the Highlands where guests can cook meals, wash clothing, shower, use Internet and mobile phones, print boarding passes, and rest comfortably. The new nonprofit is led by two unpaid, full-time volunteers and many additional volunteers from church congregations across Caddo Parish. The team is also actively coordinating with their counterparts in other Louisiana cities.

Over 436 immigrants traveled through Caddo Parish between March and July 2021 and were assisted by LA-AID. Between July – December 2021, our volunteers drove 16,378 miles and helped 798 people from over 46 countries reunite with family and friends around the United States as they safely traveled through Caddo Parish.

While we are glad to help guests in need unite their families safely, hosting new and unexpected guests for weeks and weeks has also pushed the limits of our professional capacity and the generosity of our hosts. Support from the Parish of Caddo would help ensure that our organization is able to continue operating and meet the public safety crisis that has emerged in our region.

**ATTACHMENT A: CONTACT INFORMATION**

List the names, addresses, and Commission District (if applicable) of all board members.

<b>Name</b>	<b>Address</b>	<b>Commission District</b>
Frances Kelley	935 Linden Street Shreveport, LA 71104	4
Michelle LaFleur MacFadyen	107 Silverbell Parkway Lafayette, LA 70508	NA
Leslie Elliottsmith	6006 Navaho Trail Alexandria, LA 71301	NA

## ATTACHMENT B: PROJECT TIMELINE

**This summary should provide a written timeline to show benchmarks for project implementation and completion. Describe any recent, relevant and successfully demonstrated experience in undertaking similar projects. Include the knowledge and experience of the proposed day-to-day project team leader.**

Building on the past year of effective work, from January 1, 2022, to June 30, 2022, the Caddo-based chapter of the nonprofit LA-AID will ensure that asylum seekers- who are approved to travel through Caddo Parish from the nearest three Immigrant and Customs Enforcement detention centers to their families and friends across the United States- will have safe and professional assistance with translation, transportation, and essential needs as the federal agency improves their processes and the state-wide agency builds capacity to accommodate and support this new, regional humanitarian and public safety crisis.

**ATTACHMENT C:**

**Caddo Parish Appropriation BUDGET FORM**

Please provide detailed explanation of each line item.

<b>Organization Name</b>	LA-AID			
<b>Budget Year</b>	2022			
	<b>Funding Amount</b>			
<b>Line Item Object</b>	<b>Parish Amount</b>	<b>Other Amounts*</b>	<b>In-Kind (Including Food Bank)</b>	<b>Total</b>
Facility		\$20,790.00		\$20,790.00
Personnel			\$55,000.00	\$55,000.00
Mileage		\$2,100.00		\$2,100.00
Meals	\$5,494.00	\$2,640.00		\$8,170.00
Telecommunications	\$1,400.00	\$676.00		\$2,076.00
Supplies	\$920.00		\$2,280.00	\$3,200.00
Repairs	\$1,750.00	\$1,850.00		\$3,600.00
Airport Parking		\$540.00		\$540.00
Insurance	\$436.00	\$514.00		\$950.00
<b>Total</b>	\$10,000.00	\$29,110.00	\$57,280.00	\$96,426.00

\*Please provide a detailed listing of the funding source for other amounts.

\*If funding tuition for low-income persons to attend your program, please provide a detailed listing of the items covered by the tuition.



Department of the Treasury  
Internal Revenue Service  
Tax Exempt and Government Entities  
P.O. Box 2508  
Cincinnati, OH 45201

LOUISIANA ADVOCATES FOR  
IMMIGRANTS IN DETENTION  
262 WILKINSON STREET  
SHREVEPORT, LA 71104

**Date:**  
01/07/2022  
**Employer ID number:**  
87-2935596  
**Person to contact:**  
Name: Customer Service  
ID number: 31954  
Telephone: (877) 829-5500  
**Accounting period ending:**  
December 31  
**Public charity status:**  
170(b)(1)(A)(vi)  
**Form 990 / 990-EZ / 990-N required:**  
Yes  
**Effective date of exemption:**  
September 28, 2021  
**Contribution deductibility:**  
Yes  
**Addendum applies:**  
No  
**DLN:**  
26053691002261

Dear Applicant:

We're pleased to tell you we determined you're exempt from federal income tax under Internal Revenue Code (IRC) Section 501(c)(3). Donors can deduct contributions they make to you under IRC Section 170. You're also qualified to receive tax deductible bequests, devises, transfers or gifts under Section 2055, 2106, or 2522. This letter could help resolve questions on your exempt status. Please keep it for your records.

Organizations exempt under IRC Section 501(c)(3) are further classified as either public charities or private foundations. We determined you're a public charity under the IRC Section listed at the top of this letter.

If we indicated at the top of this letter that you're required to file Form 990/990-EZ/990-N, our records show you're required to file an annual information return (Form 990 or Form 990-EZ) or electronic notice (Form 990-N, the e-Postcard). If you don't file a required return or notice for three consecutive years, your exempt status will be automatically revoked.

If we indicated at the top of this letter that an addendum applies, the enclosed addendum is an integral part of this letter.

For important information about your responsibilities as a tax-exempt organization, go to [www.irs.gov/charities](http://www.irs.gov/charities). Enter "4221-PC" in the search bar to view Publication 4221-PC, Compliance Guide for 501(c)(3) Public Charities, which describes your recordkeeping, reporting, and disclosure requirements.

Sincerely,

Stephen A. Martin  
Director, Exempt Organizations  
Rulings and Agreements

**AFFIDAVIT**

I hereby certify that the information provided in this application and all accompanying forms is true and accurate as of the date of completion.

**Signature:**

Frances Kelley

**Title:**

Board Secretary

**Date:**

1/26/22



(https://www.sos.la.gov/Pages/default.aspx)

**Search for Louisiana Business Filings**

[Buy Certificates and Certified Copies](#) [Subscribe to Electronic Notification](#) [Print Detailed Record](#)

<b>Name</b>	<b>Type</b>	<b>City</b>	<b>Status</b>
LOUISIANA ADVOCATES FOR IMMIGRANTS IN DETENTION	Non-Profit Corporation	SHREVEPORT	Active

**Previous Names**

**Business:** LOUISIANA ADVOCATES FOR IMMIGRANTS IN DETENTION  
**Charter Number:** 44613657N  
**Registration Date:** 10/1/2021

**Domicile Address**

262 WILKINSON STREET  
 SHREVEPORT, LA 71104

**Mailing Address**

262 WILKINSON STREET  
 SHREVEPORT, LA 71104

**Status**

**Status:** Active  
**Annual Report Status:** In Good Standing  
**File Date:** 10/1/2021  
**Last Report Filed:** N/A  
**Type:** Non-Profit Corporation

**Registered Agent(s)**

<b>Agent:</b>	MADISON POCHE
<b>Address 1:</b>	262 WILKINSON STREET
<b>City, State, Zip:</b>	SHREVEPORT, LA 71104
<b>Appointment Date:</b>	10/1/2021

**Officer(s)**

Additional Officers: No

<b>Officer:</b>	FRANCES KELLEY
<b>Title:</b>	Director
<b>Address 1:</b>	935 LINDEN STREET
<b>City, State, Zip:</b>	SHREVEPORT, LA 71104
<b>Officer:</b>	MICHELLE LAFLEUR MACFADYEN
<b>Title:</b>	Director
<b>Address 1:</b>	107 SILVERBELL PARKWAY
<b>City, State, Zip:</b>	LAFAYETTE, LA 70508
<b>Officer:</b>	LESLIE ELLIOTTSMITH
<b>Title:</b>	Director
<b>Address 1:</b>	6006 NAVAHO TRAIL
<b>City, State, Zip:</b>	ALEXANDRIA, LA 71301

**Amendments on File**

No Amendments on file

[Back to Search Results](#) [New Search](#) [View Shopping Cart](#)

GET HELP

# PARISH OF CADDO, LOUISIANA

## GUIDELINES FOR APPROPRIATION APPLICATIONS

Name of Entity: Louisiana Advocates for Immigrants in Detention (LA-AID)

**Please review the following guidelines for funding and initial indicating you have read and understand each item prior to submitting an application:**

- FK 1. Appropriations are made on an annual basis; **receiving funding one year does not guarantee that the organization will receive funds in the same amount, or at all during the next year.**
- FK 2. Funds are appropriated for specific programs that an organization sponsors and **cannot be used for the day-to-day operating expenses of the organization (i.e. salaries, office expenses, rent).**
- FK 3. The program for which an appropriation is requested must provide services to unskilled poor, low-income persons, unemployed persons or students from those families; alternatively, the program must provide a measurable means of economic development for Caddo Parish.
- FK 4. Funds cannot be used for the following:
  - a. Capital purchases/improvements such as building repairs/renovations, playground equipment (even if for the parish-funded program) of an organization;
  - b. Equipment used in any other program other than the one the Parish is funding;
  - c. To benefit non-Caddo citizens.
- FK 5. Funds cannot be used directly or indirectly in any trade or business carried on by any person or entity other than Grantee.
- FK 6. An organization receiving monies through the Caddo Parish Commission's appropriation process must give two reports detailing the use of those funds: a report detailing the use of the funds from January 1<sup>st</sup> - June 30<sup>th</sup> of the appropriation year (due July 31<sup>st</sup>), and a report detailing the use of the funds from July 1<sup>st</sup> - December 31<sup>st</sup> of the appropriation year (due January 31<sup>st</sup> of the year following the appropriation). A subsequent appropriation application will **not** be considered if the July 31<sup>st</sup> report has not been timely submitted; an approved appropriation will **not** be funded if the January 31<sup>st</sup> report has not been timely submitted. These reports must include invoices, receipts cancelled checks and any other documents related to the expenditure of Parish funds, and the Parish reserves the right to audit all organization records related to the appropriation at any time.
- FK 7. No funds will be paid until all required reports have been received and approved by the Parish of Caddo.
- FK 8. Funds must be spent **in accordance with the provisions outlined in the Cooperative Endeavor Agreement (CEA)**. Listing items in the detailed budget does not make them eligible for reimbursement; the items must be covered in the CEA.

# SECTION I: INTRODUCTION AND FUNDING PURPOSE

It is important that each section of this request be completed.

1. Name of Entity: Louisiana Advocates for Immigrants in Detention

Commission District: District 4

Address: 520 Olive Street

Shreveport, LA 71104

Is this the address of the organization's headquarters?  Yes  No

If not, please list headquarter address: \_\_\_\_\_

Does your organization provide services in more than one commission district?

Yes  No

If yes please list other districts served and addresses (if available):

District \_\_\_\_\_

District \_\_\_\_\_

Address \_\_\_\_\_

Address \_\_\_\_\_

Contact Person: Mr. / Mrs. / Ms. Frances Kelley

Title: Board Secretary

Phone Number: ( 318 ) 780-4138

Fax: ( \_\_\_\_\_ ) \_\_\_\_\_

Email: frances.elizabeth.kelley@gmail.com

Past Grant Recipient?  Yes  No

2. Purpose for which Parish funds would be used (Check one and give brief description):

Economic Development:

Education:

Social Welfare:

Abate public safety and humanitarian crisis related to illegal implementation of federal laws on immigration impacting Caddo Parish

3. Amount of this funding request: \$10,000

4. During what time period will the funds be used: Jan. 1, 2022 through December 30, 2022

5. Are audited financial statements available?  Yes  No

Please furnish most recent financial statement period covered:

July 1, 2021 through December 30, 2021

6. Are you exempt from Federal Income Tax?  Yes  No

Under IRS Code Section: 501(c)(3)

7. Have you filed form 990 (Return of Organization Exempt from Income Tax)?  Yes  No

Date of last time filed: \_\_\_\_\_

8. Quarterly drawdowns are agreed to be acceptable:  Yes  No

*(If not, please propose an alternate drawdown schedule and explain)*

9. Does the organization have any outstanding tax claims (City, Parish, State or Federal)?

Yes  No *(If so, please explain claim)*

10. Are you in good standing with the State of Louisiana?  Yes  No

Please provide a copy of your Certificate of Good Standing.

N/A

11. Please attach any other information that you wish to submit in support of your application.

## SECTION II: PROPOSAL NARRATIVE

The proposal narrative must be formatted as outlined below. Proposals that are not submitted in the following format will not be reviewed. This section shall not exceed three pages, double spaced in 12-font. The application outline must address all of the following items below:

### **Background and Capacity of Organization**

Briefly describe your organization. This description should include the length of existence, the number of officers, members, and mission. Explain the organization's capacity to successfully implement the proposed project in a timely manner.

### **Prior Experience of Organization**

Description of past completed projects involving community and Parish activities in the past three (3) years, including the type of project, project location, and how it benefited the Parish.

### **Extent of Neighborhood Involvement**

Describe the manner in which you will attract volunteers to your project. Describe how a significant number of people with diverse interests in the neighborhood will be involved in and benefit from this project.

### **Description of Project and Soundness of Project**

This summary should provide an overview of entire project(s), including project location and how this project will benefit the Parish. This project must be clearly understood, well planned, and ready to proceed.

### **Joint Group Application and Collaboration**

State whether your organization is submitting this application along with another Parish-based organization. Also, describe any partnerships that were formed or will be formed to plan and implement this project. Please include names of all partnerships, consultants and other organizations that Caddo Parish appropriations will fund with the amount of monies going to each.

### **Identify Needs and Gaps in Services in Neighborhood**

List the priority needs that the organization has identified in the neighborhood along with any gaps of services that have been noted.

## ATTACHMENT A: CONTACT INFORMATION

List the names, addresses, and Commission District (if applicable) of all board members.

Name	Address	Commission District
Frances Kelley	935 Linden Street Shreveport, LA 71104	4
Michelle LaFleur MacFadyen	107 Silverbell Parkway Lafayette, LA 70508	NA
Leslie Elliottsmith	6006 Navaho Trail Alexandria, LA 71301	NA

## ATTACHMENT B: PROJECT TIMELINE

**This summary should provide a written timeline to show benchmarks for project implementation and completion. Describe any recent, relevant and successfully demonstrated experience in undertaking similar projects. Include the knowledge and experience of the proposed day-to-day project team leader.**

Building on the past year of effective work, from January 1, 2022, to June 30, 2022, the Caddo-based chapter of the nonprofit LA-AID will ensure that asylum seekers- who are approved to travel through Caddo Parish from the nearest three Immigrant and Customs Enforcement detention centers to their families and friends across the United States- will have safe and professional assistance with translation, transportation, and essential needs as the federal agency improves their processes and the state-wide agency builds capacity to accommodate and support this new, regional humanitarian and public safety crisis.

**ATTACHMENT C:**  
**Caddo Parish Appropriation BUDGET FORM**  
Please provide detailed explanation of each line item.

Organization Name LA-AID

Budget Year 2022

Line Item Object	Funding Amount			Total
	Parish Amount	Other Amounts*	In-Kind (Including Food Bank)	
Facility		\$20,790.00		\$20,790.00
Personnel			\$55,000.00	\$55,000.00
Mileage		\$2,100.00		\$2,100.00
Meals	\$5,494.00	\$2,640.00		\$8,170.00
Telecommunications	\$1,400.00	\$676.00		\$2,076.00
Supplies	\$920.00		\$2,280.00	\$3,200.00
Repairs	\$1,750.00	\$1,850.00		\$3,600.00
Airport Parking		\$540.00		\$540.00
Insurance	\$436.00	\$514.00		\$950.00
<b>Total</b>	\$10,000.00	\$29,110.00	\$57,280.00	\$96,426.00

\*Please provide a detailed listing of the funding source for other amounts.

\*If funding tuition for low-income persons to attend your program, please provide a detailed listing of the items covered by the tuition.

**AFFIDAVIT**

**I hereby certify that the information provided in this application and all accompanying forms is true and accurate as of the date of completion.**

**Signature:**

\_\_\_\_\_

**Title:**

\_\_\_\_\_

**Date:**

\_\_\_\_\_

## CHECKLIST OF REQUIRED DOCUMENTS

### Guidelines For Appropriation Applications

Application

Proposal Narrative (See application outline on page 3)

Attachment A

Attachment B

Attachment C

Copy of current IRS 501(c)(3) tax exempt statement indicating that you are not a private foundation and an explanation of any changes in your IRS status (if applicable)

Affidavit

Copy of Certificate of Good Standing with State of Louisiana

**ORDINANCE NO. 6193 OF 2022**

BY THE CADDO PARISH COMMISSION:

**AN ORDINANCE CREATING THE I-49 NORTH CORRIDOR ECONOMIC DEVELOPMENT DISTRICT, STATE OF LOUISIANA;" DEFINING THE BOUNDARIES THEREOF FROM WHICH AREA LOCAL SALES TAX, PROPERTY TAX AND HOTEL OCCUPANCY TAX INCREMENTS WILL BE DETERMINED AND USED TO FINANCE ECONOMIC DEVELOPMENT PROJECTS IN ACCORDANCE WITH AND AS AUTHORIZED BY PART II OF CHAPTER 27 OF TITLE 33 OF THE LOUISIANA REVISED STATUTES OF 1950, AS AMENDED; AND PROVIDING FOR OTHER MATTERS IN CONNECTION WITH THE FOREGOING.**

**WHEREAS**, Part II, Chapter 27, Title 33 of the Louisiana Revised Statutes of 1950, as amended (La. R S. 33:9038.31, *et seq.*) (the "EDD Act") authorizes municipalities, parishes and certain other local governmental subdivisions to create economic development districts to carry out the purposes of the Act, which economic development districts are political subdivisions of the State of Louisiana and possess such power and authority and have such duties as provided by the Act and other law; and

**WHEREAS**, La. R S. 33:9038.39 further permits such economic development districts tolevy sales and use taxes and hotel occupancy taxes at a rate up to two percent (2%) for authorized purposes subsequent to the creation and establishment of the District; and

**WHEREAS**, La. R S. 33:9038.34(O) provides that this governing authority may create a special trust fund for the furtherance of economic development projects, as defined in the EDD Act, into which the incremental increases in such sales taxes, property taxes and hotel occupancy taxes shall be deposited and loaned, granted, donated, or pledged in furtherance of economic development projects as defined in the EDD Act; and

**WHEREAS**, the Parish of Caddo, State of Louisiana (the "Parish"), acting through this Parish Commission as its governing authority, desires to avail itself of the EDD Act to create an economic development district to be called The "I-49 North Corridor Economic Development District, State of Louisiana" (the "District"), in accordance with La. R S. 33:9038.32, from which District local and State sales tax increments and local property and hotel occupancy tax increments are expected to be determined and used to fund the Parish of Caddo Economic Development District Trust Fund; and

**WHEREAS**, in accordance with the Act, particularly La. R S. 33:9038.32(8) and La. R S. 33:9038.39, and Resolution No. ? adopted on ?, 2021, the Parish has given notice of its intention to create the District, and notice that it will hold a public hearing relative to the proposed creation of the District, including a description of the boundaries of the District and containing a map showing the boundaries of the District, which notice has been published two times in the Parish's official journal; and

**WHEREAS**, on this date, prior to the adoption of this ordinance, this governing authority did hold a public hearing pursuant to the aforesaid notice of intention, at which public hearing no objections were received with respect to the creation of the District.

**NOW, THEREFORE, THE COMMISSION FOR THE PARISH OF CADDO HEREBY ORDAINS:**

SECTION 1. All of the above "Whereas" clauses are adopted as a part of this ordinance.

SECTION 2. Creation of District. Under the authority of La. R S. 33:9038.32 there is hereby created an economic development district within the Parish, to be named the "I-49 North Corridor Economic Development District, State of Louisiana," having the geographical boundaries set forth in Exhibit A attached hereto, which Exhibit A is hereby incorporated in and made a part of this Ordinance, all pursuant to the EDD Act. As provided by the EDD Act, the governing body of the District shall be this Parish Commission. As provided by the EDD Act, the District shall be a political subdivision of the State of Louisiana and shall possess such powers and authority and have such duties as provided in the EDD Act and other law.

SECTION 3. Creation of Trust Fund. Under the authority of La. RS. 33:9038.34(O), there is hereby created a special trust fund, to be named the "Parish of Caddo Economic Development District Trust Fund" (the "Trust Fund") the purpose of which will be to fund economic development projects selected by the District in the manner provided by the EDD Act. The Trust Fund shall be established by the Director of Finance of the Parish and maintained as a separate fund, apart from other funds and accounts of the Parish or other entities, and shall be used strictly for the purposes set forth herein and in the EDD Act.

SECTION 4. Authorization of Officers. The Parish Administrator is hereby authorized, empowered and directed to do any and all things necessary and incidental to carry out the provisions of this ordinance.

SECTION 5. Severability. If any provision of this ordinance shall be held to be illegal or invalid, such illegality or invalidity shall not affect any other provision of this ordinance, but this ordinance shall be construed and enforced as if such illegal or invalid provisions had not been contained herein. Any constitutional or statutory provision enacted after the date of this ordinance which validates or makes legal any provision of this ordinance which would not otherwise be valid or legal, shall be deemed to apply to this ordinance.

**BE IT FURTHER ORDAINED**, that this ordinance, shall become effective ten (10) days after publication.

**BE IT FURTHER ORDAINED**, that all ordinances or parts thereof in conflict herewith are hereby repealed.

Approved as to legal form:

---

Parish Attorney

## **EXHIBIT A to Creation Ordinance**

**BOUNDARIES AND MAP OF PROPOSED I-49 NORTH CORRIDOR  
ECONOMIC DEVELOPMENT DISTRICT, STATE OF LOUISIANA  
A CERTAIN TRACT OR PARCEL OF LAND SITUATED IN CADDO, PARISH,  
LOUISIANA AND BEING MORE PARTICULARLY DESCRIBED AS  
FOLLOWS:**

7.498 acres to be defined as from: That part of the Southeast Quarter (SE1/4) of Section Thirteen (13), Township Twenty-two (22) North, Range Fifteen (15) West, lying South of the North right of way line of the Hosston-Miller's Bluff Road and East of the West Bank of Kelly Bayou Canal and all of the South Half of the Southwest Quarter (S1/2 of SW1/4) of Section Thirteen (13), Township Twenty-two (22) North, Range Fifteen (15) West, lying East of the West bank of Kelly Bayou Canal

**ORDINANCE AND RESOLUTION FACT SHEET**

**CADDO PARISH COMMISSION**

<b>TITLE</b>	
Ordinance No. <u>6193</u> of 2022	
AN ORDINANCE CREATING THE I-49 NORTH CORRIDOR ECONOMIC DEVELOPMENT DISTRICT, STATE OF LOUISIANA;" DEFINING THE BOUNDARIES THEREOF FROM WHICH AREA LOCAL SALES TAX, PROPERTY TAX AND HOTEL OCCUPANCY TAX INCREMENTS WILL BE DETERMINED AND USED TO FINANCE ECONOMIC DEVELOPMENT PROJECTS IN ACCORDANCE WITH AND AS AUTHORIZED BY PART II OF CHAPTER 27 OF TITLE 33 OF THE LOUISIANA REVISED STATUTES OF 1950, AS AMENDED; AND PROVIDING FOR OTHER MATTERS IN CONNECTION WITH THE FOREGOING	
DATE: 1/28/2022	ORIGINATING DEPARTMENT: Legal for Commissioner Hopkins
<b>BACKGROUND INFORMATION</b>	
Commissioner Hopkins has requested an ordinance be prepared with boundaries that conform to the boundaries in the notice of intent resolution appearing on the January 31 <sup>st</sup> work session agenda. This property is a truck stop and travel center for which the IDB is also doing a PILOT lease. The TIF District boundaries will only cover the truck stop and travel center property.	
<b>FINANCIAL IMPACT AND SOURCE OF FUNDING</b>	
None	
<b>EFFECT(S) OF PROPOSED ACTION</b>	
Passage of the ordinance will result in the creation of the TIF District; failure to pass it will result in the TIF District not being created.	
<b>ALTERNATIVES/STAFF RECOMMENDATION</b>	
Staff has no recommendation.	
<b>KEY STAFF CONTACT</b>	
Donna Frazier, Parish Attorney	
<b>COORDINATION</b>	
Department Head	(Initial) <i>DF</i>
Parish Administrator/CEO	(Initial) <i>DF</i>

ORDINANCE NO. 6194 of 2022

BY THE CADDO PARISH COMMISSION

**AN ORDINANCE TO ACCEPT THE STREETS IN  
OLD TOWNE SUBDIVISION UNIT 1 INTO THE  
PARISH OF CADDO ROAD SYSTEM, AND TO  
OTHERWISE PROVIDE WITH RESPECT THERETO**

WHEREAS, the Parish of Caddo has received a request to accept the streets in Old Towne Subdivision Unit 1, into the Parish of Caddo road system;

WHEREAS, the Parish of Caddo has received and reviewed the subdivision plats showing a dedication to the Parish of Caddo; and

WHEREAS, the Parish of Caddo finds that the acceptance of the subdivisions into the Parish of Caddo system is in the best interest of the Parish of Caddo.

NOW, THEREFORE BE IT ORDAINED by the Caddo Parish Commission, in due, legal and regular session convened, that the Parish of Caddo hereby accepts into the Parish of Caddo road system all of the streets in Old Towne Subdivision Unit 1, Caddo Parish, Louisiana as shown on the attached subdivision plat marked as "Exhibit A".

BE IT FURTHER ORDAINED that a copy of this ordinance, with a subdivision plat of the Old Towne Subdivision Unit 1 attached thereto as "Exhibit A", shall be filed in the conveyance records of the Parish of Caddo.

BE IT FURTHER ORDAINED that if any provision or item of this ordinance or application thereof is held invalid, such invalidity shall not affect other provisions, items, or applications which can be given effect without the invalid provision, items or applications, and to this end, the provisions of this ordinance are hereby declared severable.

BE IT FURTHER ORDAINED that this ordinance shall be effective ten days after publication in the official journal.

BE IT FURTHER ORDAINED, that all ordinances or parts thereof in conflict herewith are hereby repealed.

Approved as to legal form:

\_\_\_\_\_  
Parish Attorney's Office

\_\_\_\_\_  
Date



# OLD TOWNE SUBDIVISION UNIT I (SHEET 1 OF 2)

A SUBDIVISION OF 26.76 ACRES IN SECTION 3, TOWNSHIP 18 NORTH, RANGE 15 WEST  
CADDO PARISH, LA.

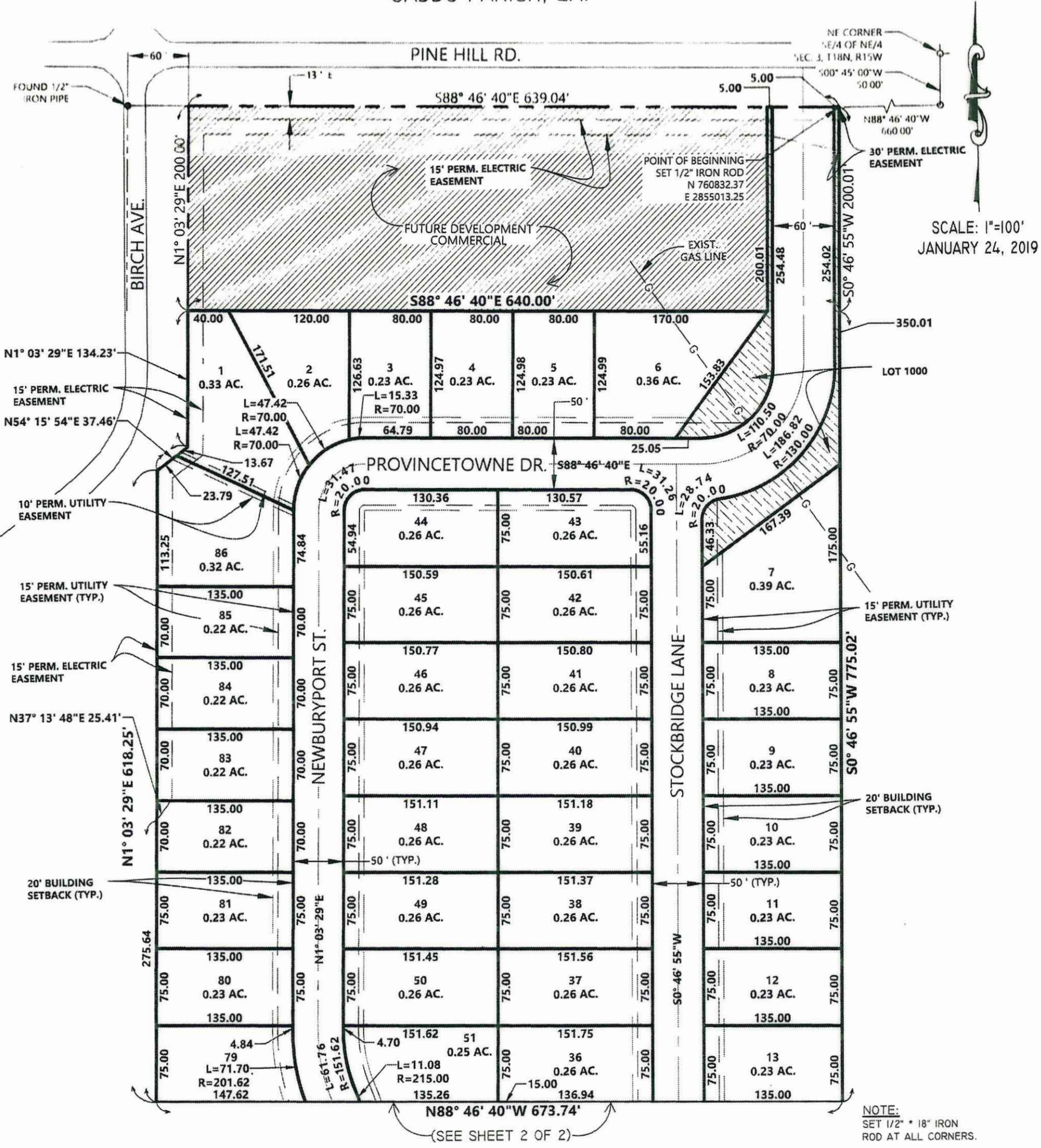

**DEDICATION:** THE UNDERSIGNED OWNER HEREBY DEDICATES TO THE PUBLIC FOR PUBLIC USE THE STREETS AS SHOWN. THE UNDERSIGNED OWNER HEREBY GRANTS UNTO THE TOWN OF BLANCHARD, AEP SWPCO, BELL SOUTH TELEPHONE COMPANY, ARKLA GAS, MACCO COMMUNICATIONS AND/OR ANY OTHER UTILITY, PUBLIC OR PRIVATE, THEIR RESPECTIVE SUCCESSORS AND ASSIGNS, EXCLUSIVELY AND IN PERPETUITY AS A COVENANT RUNNING WITH THE LAND THE RIGHT TO GO UPON THE SEVITUDES FOR UTILITIES HEREIN ESTABLISHED TO INSTALL, MAINTAIN, AND REMOVE FACILITIES APPROPRIATE TO THEIR SERVICES: TO HAVE INGRESS AND EGRESS THERETO OVER ADJACENT LOTS AND LAND; AND/OR CUT AND REMOVE TREES OR OTHER OBSTRUCTIONS AS MAY INTERFERE WITH OR ENDANGER LIFE OR THE OPERATION OF SUCH FACILITIES OR THEIR EFFICIENCY; AND FURTHER AGREES TO HOLD HARMLESS THE PARISH OF CADDO FROM DAMAGES DUE TO CHANGES IN THE STREET GRADES. BINDING HEREIN THEIR HEIRS, SUCCESSORS, AND ASSIGNS.

**RECORD OWNERS:**  
E & L DEVELOPMENT, LLC  
*[Signature]* 4-16-19  
KENNETH G. LAWLER DATE  
PRESIDENT  
Mike Spence, Caddo Clerk of Court  

**APPROVAL:**  
*[Signature]* 7/18/19  
MAYOR, TOWN OF BLANCHARD DATE

*[Signature]* 7-2-19  
CADDO PARISH DATE  
DIRECTOR OF PUBLIC WORKS

APPROVAL OF THIS PLAT BY THE PARISH OF CADDO DOES NOT CONSTITUTE AN ACCEPTANCE BY THE PARISH OF CADDO, OR THE PUBLIC, OF ANY OR THE PUBLIC, OF ANY STREETS, DRAINAGE OR OTHER RIGHTS OF WAYS AS SHOWN ON THIS PLAT. ALL STREETS AND ALL DRAINAGE SHALL BE IN ACCORDANCE AND COMPLIANCE WITH CHAPTER 22 OF THE CODE OF ORDINANCES OF THE PARISH OF CADDO. IN ACCORDANCE WITH L.A. R.S. 33:5051c.(1), THE APPROVAL OF THIS PLAT SHALL NOT CONSTITUTE ACCEPTANCE BY THE PUBLIC OF ANY STREET OR OTHER PUBLIC, WAY, PARK OR SPACE. SUCH APPROVAL CAN ONLY BE EFFECTED BY ACTION OF THE CADDO PARISH COMMISSION. BEARINGS ARE BASED UPON PLAT RECORDED IN BOOK 2300, PAGES 126-127, INCLUSIVE. PER FIRM PANEL 22017C 0335H, DATED MAY 19, 2014, THIS SUBDIVISION IS IN ZONE X.

**NOTES:**  
I, HEREBY CERTIFY THAT THIS SUBDIVISION PLAT CONFORMS TO ALL REGULATIONS AND REQUIREMENTS OF THE SUBDIVISION ORDINANCE AND AMENDMENTS THERETO AS ADOPTED BY THE CADDO PARISH COMMISSION EXCEPT AS RELATED TO ROADS AND DRAINAGE; AND, THAT THIS MAP REPRESENTS AN ACTUAL GROUND SURVEY BY ME OR UNDER MY SUPERVISION.



*[Signature]* 04.16.19

2750186 Pages: 1  
07/08/2019 03:33 PM



ORDINANCE NO. 6195 of 2022

BY THE CADDO PARISH COMMISSION

**AN ORDINANCE TO ACCEPT THE STREETS IN  
BLANCHARD LAKE ESTATES UNIT 4 INTO THE  
PARISH OF CADDO ROAD SYSTEM, AND TO  
OTHERWISE PROVIDE WITH RESPECT THERETO**

WHEREAS, the Parish of Caddo has received a request to accept the streets in Blanchard Lake Estates Unit 4, into the Parish of Caddo road system;

WHEREAS, the Parish of Caddo has received and reviewed the subdivision plats showing a dedication to the Parish of Caddo; and

WHEREAS, the Parish of Caddo finds that the acceptance of the subdivisions into the Parish of Caddo system is in the best interest of the Parish of Caddo.

NOW, THEREFORE BE IT ORDAINED by the Caddo Parish Commission, in due, legal and regular session convened, that the Parish of Caddo hereby accepts into the Parish of Caddo road system all of the streets in Blanchard Lake Estates Unit 4, Caddo Parish, Louisiana as shown on the attached subdivision plat marked as "Exhibit A".

BE IT FURTHER ORDAINED that a copy of this ordinance, with a subdivision plat of the Blanchard Lake Estates Unit 4 attached thereto as "Exhibit A", shall be filed in the conveyance records of the Parish of Caddo.

BE IT FURTHER ORDAINED that if any provision or item of this ordinance or application thereof is held invalid, such invalidity shall not affect other provisions, items, or applications which can be given effect without the invalid provision, items or applications, and to this end, the provisions of this ordinance are hereby declared severable.

BE IT FURTHER ORDAINED that this ordinance shall be effective ten days after publication in the official journal.

BE IT FURTHER ORDAINED, that all ordinances or parts thereof in conflict herewith are hereby repealed.

Approved as to legal form:

\_\_\_\_\_  
Parish Attorney's Office

\_\_\_\_\_  
Date



# BLANCHARD LAKE ESTATES UNIT 4

A SUBDIVISION LOCATED IN SECTION 34, TOWNSHIP 19 NORTH, RANGE 15 WEST, AND SECTION 3, TOWNSHIP 18 NORTH, RANGE 15 WEST IN CADDO PARISH, LOUISIANA CONTAINING 8.805 ACRES.

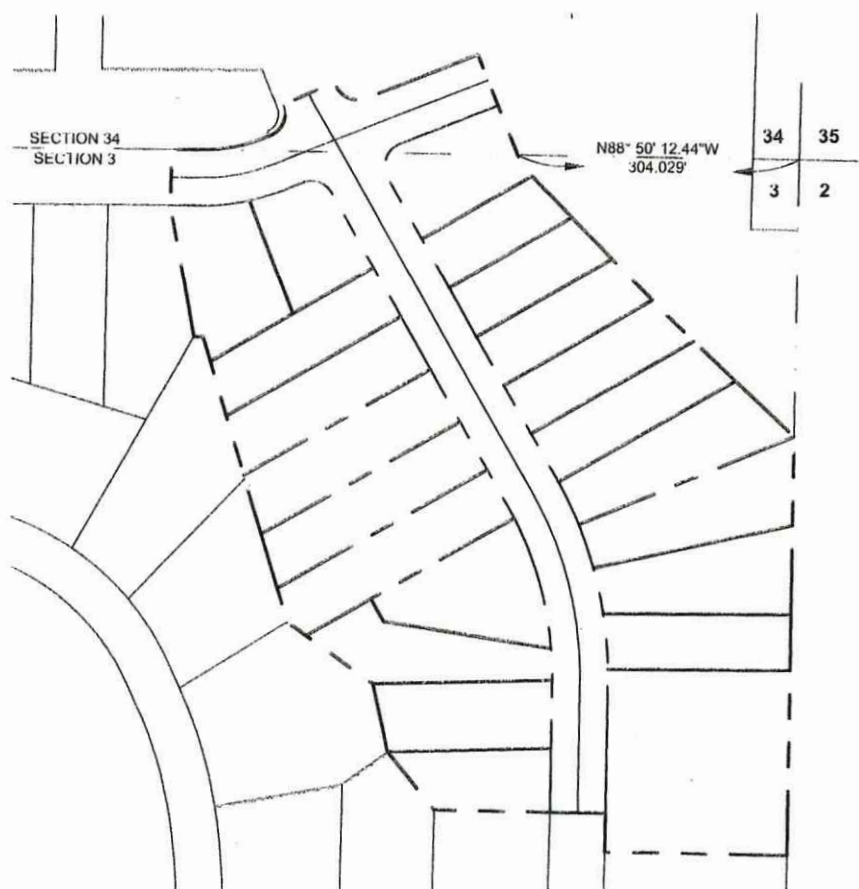

0' 100' 200' 400'  
SCALE: 1"=200'  
DATE: JANUARY 2020

Mike Spence, Caddo Clerk of Court



2777064 Pages: 2  
02/07/2020 10:59 AM

THE UNDERSIGNED OWNER(S) DEDICATES TO THE PUBLIC USE IN PERPETUITY THE STREETS AND EASEMENTS FOR UTILITIES AND DRAINAGE AS SHOWN ON THE SUBDIVISION PLAT. FOR VALUABLE CONSIDERATION THE UNDERSIGNED OWNER(S) HEREBY GRANTS UNTO SOUTHWESTERN ELECTRIC POWER COMPANY, BELL SOUTH TELECOMMUNICATIONS AND/OR ANY OTHER UTILITY, PUBLIC OR PRIVATE, THEIR RESPECTIVE SUCCESSORS OR ASSIGNS EXCLUSIVELY AND IN PERPETUITY, AS A COVENANT RUNNING WITH THE LAND THE RIGHT TO GO UPON THE EASEMENTS FOR UTILITIES HEREIN ESTABLISHED TO INSTALL, MAINTAIN AND REMOVE FACILITIES APPROPRIATE TO THEIR SERVICES, TO HAVE INGRESS AND EGRESS THERETO OVER ADJACENT LOTS AND LAND, TO TRIM AND/OR CUT AND REMOVE TREES OR OTHER OBSTRUCTIONS AS MAY INTERFERE WITH OR ENDANGER THE LIFE OR OPERATION OF SUCH FACILITIES OR THEIR EFFICIENCY, THE UNDERSIGNED OWNER(S) AGREES TO HOLD HARMLESS THE PARISH OF CADDO FOR DAMAGES DUE TO CHANGES IN THE STREET GRADES, BINDING HEREIN THEIR HEIRS AND ASSIGNS.

IT SHALL BE UNLAWFUL FOR LOTS TO BE SOLD IN THIS SUBDIVISION UNTIL ALL STREETS AND DRAINAGE SHOWN ON THIS PLAT ARE COMPLETED BY THE OWNER OR DEVELOPER, IT SHALL ALSO BE UNLAWFUL TO SELL ANY LOTS IN THIS SUBDIVISION UNTIL ALL SIDEWALKS, STREETLIGHTS, CENTRAL SEWER SYSTEMS AND WATER SYSTEMS ARE COMPLETED BY THE OWNER OR DEVELOPER IF REQUIRED BY THE SUBDIVISION REGULATIONS OF THE CADDO PARISH COMMISSION.

LOT 1000 AND 1001 ARE PRIVATELY OWNED COMMON AREAS WITH THE ENTIRETY OF EACH LOT SERVING AS A DRAINAGE EASEMENT.

PROPERTY WAS SURVEYED IN ACCORDANCE WITH THE L.A. "MINIMUM STANDARDS FOR PROPERTY BOUNDARY SURVEYS" FOR CLASS C SURVEY.

BASIS OF BEARINGS IS THE LOUISIANA COORDINATE SYSTEM OF 1983, NORTH ZONE.

SET 5/8" REBAR AT ALL PROPERTY CORNERS UNLESS SHOWN OTHERWISE.

FLOOD DESIGNATION=ZONE 'X', CADDO PARISH FLOOD INSURANCE RATE MAP NO. 22017C0335H  
EFFECTIVE DATE : MAY 19, 2014

U.S. = UTILITY SERVITUDE  
D.S. = DRAINAGE SERVITUDE  
S.B. = SETBACK

APPROVED:

TOWN OF BLANCHARD  
1/27/2020  
DATE

CADDO PARISH DIRECTOR  
OF PUBLIC WORKS  
2-5-20  
DATE

**RECORDED OWNERS:**

WASSON ROAD CO, L.L.C.

BY: ROBERT M. AIELLO  
OWNER  
01/21/20  
DATE



I HEREBY CERTIFY THAT THE PLAT OF THIS SUBDIVISION CONFORMS TO ALL REGULATIONS AND REQUIREMENTS OF THE SUBDIVISION ORDINANCE OF THE CADDO PARISH COMMISSION.

KURT M. NIXON, P.L.S.  
LA. LICENSE NUMBER 5072  
01/16/2020  
DATE

# BLANCHARD LAKE ESTATES UNIT 4

A SUBDIVISION LOCATED IN SECTION 34, TOWNSHIP 19 NORTH, RANGE 15 WEST, AND SECTION 3, TOWNSHIP 18 NORTH, RANGE 15 WEST IN CADDO PARISH, LOUISIANA CONTAINING 8.805 ACRES.

I HEREBY CERTIFY THAT THE PLAT OF THIS SUBDIVISION CONFORMS TO ALL REGULATIONS AND REQUIREMENTS OF THE SUBDIVISION ORDINANCE OF THE CADDO PARISH COMMISSION.

*Kurt M. Nixon* 01/16/2020  
 KURT M. NIXON, P.L.S. DATE  
 LA. LICENSE NUMBER 5072



Curve Table					
Curve #	Length	Radius	Delta	Chord Direction	Chord Length
C1	40.45	25.00	92.71	N22° 13' 19" E	35.18
C2	6.12	170.00	2.06	S25° 09' 56" E	6.12
C3	37.19	25.00	85.22	S68° 48' 33" E	33.85
C4	42.81	25.00	98.10	N19° 31' 37" E	37.11
C5	35.73	25.00	81.90	S70° 28' 23" E	32.11
C6	18.82	200.00	5.39	N26° 49' 48" W	18.81

Parcel Line Table		
Line #	Length	Direction
L1	32.96	S89° 04' 02.18" E
L2	23.63	N88° 34' 43.82" E

Mike Spence, Caddo Clerk of Court



2777064 Pages: 2  
 02/07/2020 10:59 AM

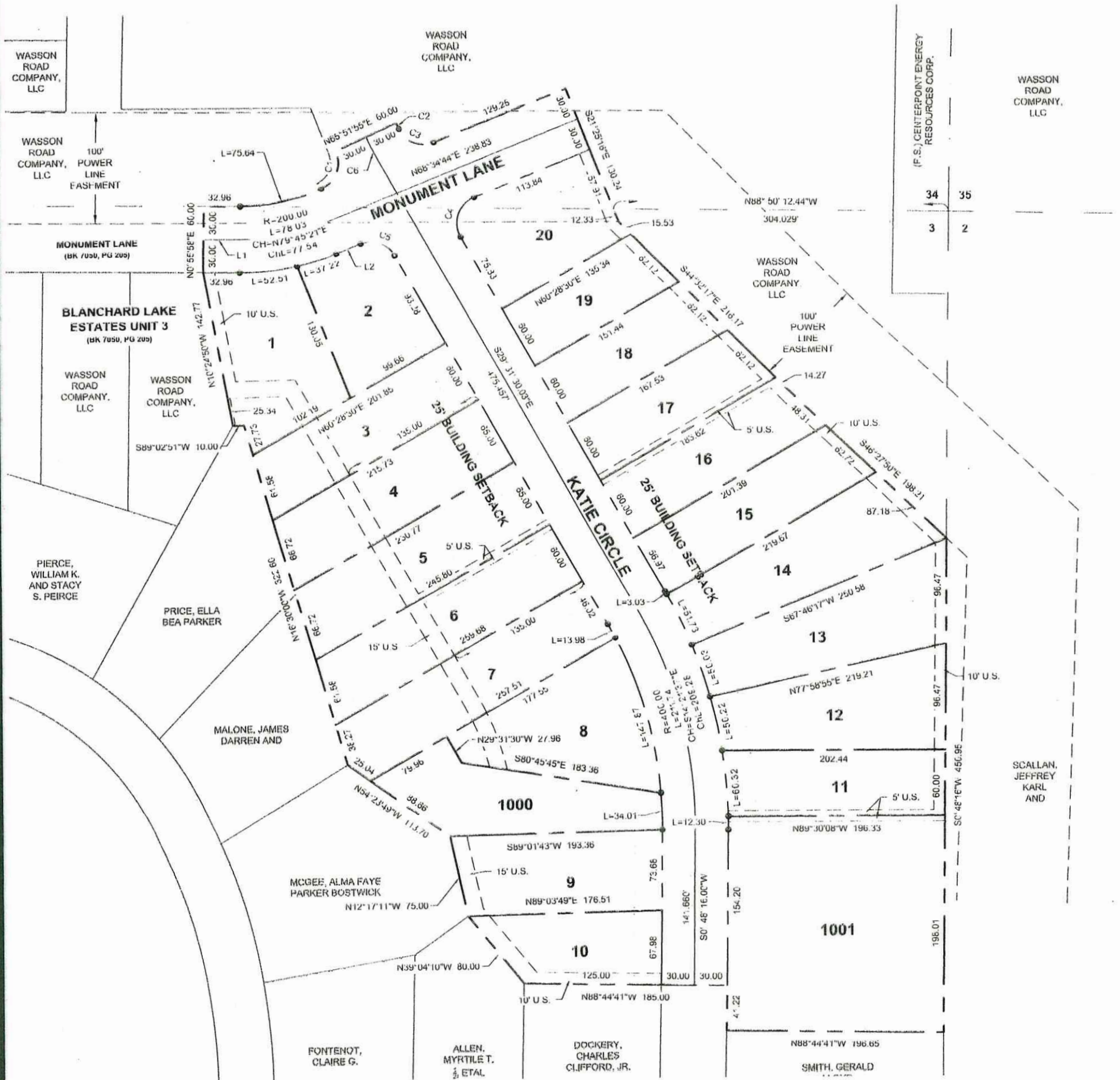

**ORDINANCE NO. 6196 OF 2022**

BY THE CADDO PARISH COMMISSION:

**AN ORDINANCE AMENDING THE BUDGET OF ESTIMATED REVENUES FOR THE AMERICAN RESCUE PLAN FUND TO PROVIDE AN APPROPRIATION FOR JUVENILE CENTER IN CADDO PARISH AND TO OTHERWISE PROVIDE WITH RESPECT THERETO**

WHEREAS, the American Rescue Plan Act of 2021 (ARPA) became law on March 11, 2021; and

WHEREAS, Caddo Parish Commission would like to appropriate a \$150,000 in 2022 and \$150,000 in 2023 to provide for funds to establish a Juvenile Center; and

WHEREAS, the Juvenile Center would provide a single point of entry for troubled youth and their families; and

WHEREAS, the Juvenile Center would provide **timely** and comprehensive assessments that link youth and families to the most appropriate community services; and

WHEREAS, the Juvenile Center would allow for the development and implementation of an integrated case management system or referral system for all clients by using a case management process that outlines intervention needs and plans, makes referrals to the indicated service, and monitors the service delivery and adjusting as needed; and

WHEREAS, the “one stop shop” approach allows the community partners to provide assessable, blended and comprehensive services to meet the needs of citizens and families. The model addresses the leading barriers to children and youth succeeding in the educational environment, while utilizing a team-based collaborative problem-solving approach among the agencies; and

WHEREAS, the appropriation was recommended by the American Rescue Plan Committee; and

NOW, THEREFORE, BE IT ORDAINED, by the Caddo Parish Commission in due, legal and regular session convened, that Budget of Estimated Revenues and Expenditures for the American Rescue Plan Fund for the year 2022 be amended as follows:

	<u>Budget Increase (Decrease)</u>
<b>American Rescue Plan Fund:</b>	
Expenditures:	
Federal Grant Expenditures	\$150,000

BE IT FURTHER ORDAINED, that if any provision or item of this ordinance or the application thereof is held invalid, such invalidity shall not affect other provisions, items or applications which can be given effect without the invalid provisions, items or applications, and to this end the provisions of this ordinance are hereby declared severable.

BE IT FURTHER ORDAINED, that this ordinance shall take effect upon adoption.

BE IT FURTHER ORDAINED, that all ordinances or parts thereof in conflict herewith are hereby repealed.

**Approved as to legal form:**

\_\_\_\_\_  
**Parish Attorney**

\_\_\_\_\_  
**Date**

# ORDINANCE AND RESOLUTION FACT SHEET

## CADDO PARISH COMMISSION

### TITLE

AN ORDINANCE AMENDING THE BUDGET OF ESTIMATED EXPENDITURES FOR THE AMERICAN RESCUE PLAN FUND AND TO OTHERWISE PROVIDE WITH RESPECT THERETO  
(Ordinance No. 6196 of 2022)

**ORIGINATING DEPARTMENT:** ARPA Committee

**BACKGROUND INFORMATION:** Amending the budget to include an appropriation for the of \$150,000 in 2022 and \$150,000 in 2023 for a Juvenile One Stop Center

The purpose of the Center is for area agencies and organizations to collaborate and provide vital services to families at one central location. The pooling of resources in the facility doesn't introduce new programs or services; rather, it reduces the length of time a juvenile must wait to have access to current community services, from several weeks to a matter of hours. Needs are addressed and determined with each juvenile based on data collected from an assessment process of testing and interviews. Information collected through this process assists staff in identifying the best approach to take with the juvenile and family. This process also makes every attempt to direct juveniles away from the juvenile justice system whenever possible, resulting in more productive outcomes for the youth and their families.

### **LIST OF SERVICES/AGENCIES TO BE OFFERED IN CENTER:**

#### **VYJ Programs:**

FINS (Families in Need of Services)

TASC (Truancy Assessment Service Center)

Conflict Resolution (School Fight Intervention/Prevention)

School Behavioral Referrals

Power of Choice (Youth Life-Skills and Parent Education)

Stamp Out Shoplifting (Theft Intervention/Prevention Program)

Mentoring

TBRI

Misdemeanor Referral Center (Serves as a clearinghouse for minor juvenile offenders)

CASA (Court Appointed Special Advocates)

#### **Agencies/Tenants:**

Caddo Parish D.A. Office – Child Support/Missing Persons

CHOICES (Mental Health Wrap-Around Services)

Center for Children and Families (Counseling – In home)

TEAMS (School Advocacy –Individualized Educational Program (IEP)

GED/HiSet Programs

High School Diploma Program

Workforce Development

Public Defender's Office attorneys

Substance Abuse Counseling/Testing

Tutoring/ACT Prep –We Tutor You & Centenary College Athletic Department  
Melanie Massey’s Physical Therapy – pediatric OT, PT, and Speech therapy  
Food Bank – SNAP benefits/meals for children’s activities  
CPJC – Substance Abuse counselors/parenting classes  
CPJC – Family Preservation Court staff/compliance officers  
CPSB Child Welfare & Attendance staff  
CPSB McKinney Vento staff  
DCFS Community Support

**Enrichment Activities:**

Computer Lab  
Summer Camps  
Health and Fitness activities and nutrition awareness (Centenary College Athletic Department)  
Uniform Closet (Porter’s Cleaners)  
Parenting Program  
After school tutoring program that also includes SEL (Social Emotional Learning) focus

**KEY STAFF CONTACT:** Hayley Barnett / Clay Walker

**AUTHORIZATION**

Department Head

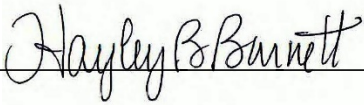
 \_\_\_\_\_

Date 02/09/2022

Legal

\_\_\_\_\_

Date \_\_\_\_\_

Parish Administrator

\_\_\_\_\_

Date \_\_\_\_\_

**ORDINANCE NO. 6197 OF 2022**

BY THE CADDO PARISH COMMISSION:

**AN ORDINANCE AMENDING THE BUDGET OF ESTIMATED REVENUES AND EXPENDITURES FOR THE RIVERBOAT FUND TO APPROPRIATE FUNDS FOR THE CADDO PARKS GRAB AND GO FEEDING PROGRAM AND TO OTHERWISE PROVIDE WITH RESPECT THERETO**

WHEREAS, Caddo Parish Parks and Recreation received the No Kid Hungry Grant for \$49,925 in 2021; and

WHEREAS, the Parks and Recreation department had huge success with feeding the youth that participated in the Parks and Recreation summer programs; and

WHEREAS, the No Kid Hungry Grant was not available in 2022; and

WHEREAS, the Caddo Parish Parks and Recreations department would like to continue the feeding program; and

WHEREAS, Caddo Parish Parks and Recreation would use these funds to provide pre-packaged summer/snacks and meals to participating youth during summer programming; and

WHEREAS, the NGO Committee recommended the appropriation; and

NOW, THEREFORE, BE IT ORDAINED, by the Caddo Parish Commission in due, legal and regular session convened, that Budget of Estimated Revenues and Expenditures for the Riverboat Fund for the year 2022 is hereby amended as follows:

Budget Increase (Decrease)

**Riverboat Fund**

Expenditures:

Summer Grab and Go Feeding Program	\$50,000
------------------------------------	----------

BE IT FURTHER ORDAINED, that if any provision or item of this ordinance or the application thereof is held invalid, such invalidity shall not affect other provisions, items or applications which can be given effect without the invalid provisions, items or applications, and to this end the provisions of this ordinance are hereby declared severable.

BE IT FURTHER ORDAINED, that this ordinance shall take effect upon adoption.

BE IT FURTHER ORDAINED, that all ordinances or parts thereof in conflict herewith are hereby repealed.

Approved as to legal form:

\_\_\_\_\_  
Parish Attorney

\_\_\_\_\_  
Date

**ORDINANCE AND RESOLUTION FACT SHEET**

**CADDO PARISH COMMISSION**

<b>TITLE</b>	
<p>ORDINANCE AMENDING THE 2022 BUDGET OF ESTIMATED REVENUES AND EXPENDITURES FOR THE RIVERBOAT FUND TO APPROPRIATE \$50,000 TO A GRAB AND GO FEEDING PROGRAM THROUGH CADDO PARKS AND RECREATION</p> <p><b>(Ordinance No. 6197 of 2022)</b></p>	
<b>ORIGINATING DEPARTMENT:</b> NGO Committee	
<b>BACKGROUND INFORMATION:</b> Amending the budget of Estimated Revenues and Expenditures for the Riverboat Fund to appropriate \$50,000 to purchase snacks and meals for Caddo youth that participate in summer programs.	
<b>KEY STAFF CONTACT:</b> Patrick Wesley / Hayley Barnett	
<b>AUTHORIZATION</b>	
Department Head	<u>Hayley B. Barnett</u> Date 2/9/2022
Legal	_____ Date _____
Parish Administrator	_____ Date _____



## **PARKS & RECREATION**

### **REQUEST FOR AMERICAN RESCUE PLAN ACT FUNDS**

Caddo Parish Parks and Recreation Department is requesting \$50,000 American Rescue Plan Act (ARPA) funds to facilitate a **“Grab and Go Feeding Program”** (snacks, lunches and after-school meals) for Caddo Parish youth, ages 4-17 who participate in 2022 recreation/wellness, athletic and nature education programs. This program was funded in 2021 through a grant award by National Recreation and Parks Association (NRPA), serving 8,160 Caddo Parish youth. This grant will not be available for the 2022 calendar year.

If approved, the “Grab and Go Feeding Program” will be a continued "game changer" in how Caddo Parish Parks and Recreation deliver quality programs and services to our Caddo Parish youth. It was evident through last year’s feeding program, that there is a vital need in Caddo Parish to provide healthy snacks and meals to our youth program participants. Many of our youth participants and respective parents expressed their sincere appreciation of Caddo Parish and highly recommended that our parks department provide this feeding program model and service annually.

Participating Caddo Parish youth will not only receive healthy grab and go snacks, lunches and after-school meals, they will also be able to participate in invaluable recreational activities, health and wellness activities, crime prevention programs, nature education programs and sport camps/clinics.

Caddo Parish Parks and Recreation Department staff, certified instructors and volunteer coaches continue to emphasize how last year’s feeding program made a significant impact in Caddo Parish. Many youth attended our recreational and athletic programs without having an adequate breakfast, snack or lunch throughout the day. Furthermore, when snacks, lunch or meals were served at our programs, some youth did not eat their entire snack, lunch or meal; but saved their food for later-because many times there was no food at their respective homes and our provided food would be there last meal for the day.

#### **Local/State Food Insecurity Statistics:**

- According to Center for Planning Excellence, over 33% of Shreveport households are now experiencing food insecurity. The national rate is 16%.
- According to Urban Footprint, communities of color are at a significantly high risk of becoming food insecure. In Louisiana, 23% of Black households are food insufficient compared with 7% of white households.

**ARPA Eligible:**

Proposed “Grab and Go Feeding Program” will place emphasis on the following:

- Public Health
- Promoting healthy childhood/youth environments
- Promoting outdoor learning and play, beyond the school day (Out-of-School Time)
- Promoting outdoor recreation and socialization to mitigate the spread of COVID-19

**(Budget Breakdown)**

**Food:**

\$35,000 (food/consumables)

**Equipment/PPE:**

\$5,000 (Gloves, masks, hand sanitizer stations, cleaning/disinfectant supplies, trash receptacles, drink coolers, food bags, tables, tents, serving utensils, warmers, etc.)

**Marketing/Promotions of Feeding Program (year-round):**

\$10,000 (radio buys, social media campaign ads, flyers, banners/signage, rack cards, etc.)

**Total Amount Requesting:**

**\$50,000.00**

**2022 Youth Programs Offered**

**(Athletics, Health and Wellness)**

Sport camps/clinics, football, basketball, baseball, Jiu-Jitsu, soccer, lacrosse, softball, track and field, weightlifting, fitness training and e-sports league.

**Estimated # of Participants**

**5,000**

**(Recreation / Education)**

Crime prevention workshops, after-school and related community outreach programs via churches and/or youth non-profit organizations.

**6,000**

**(Nature Education)**

Wild Child Summer Camps (6 sessions), Get Hooked on Fishing events, canoeing, archery activities park clean-ups and community garden activities.

**4,000**

**Estimated Number of Program Participants to be Served in 2022: 15,000**

**Estimated Number of Meals to be Served in 2022: 17,000 – 18,000**

**Compliance:**

Caddo Parish Parks and Recreation staff will comply with all required reporting guidelines.

**Program/Activity Feeding Sites:**

- Caddo Parks
- Caddo Schools
- Caddo Common Park
- Area Churches
- Lee Hedges Stadium
- Independence Stadium
- Boys and Girls Club
- Centenary College (Athletic Venues)
- Princess Park
- Holy Angels
- Town of Greenwood
- Town of Mooringsport
- Town of Vivian

**Food Vendors Used:**

- Dillas Quesadilla
- Jason's Deli
- Pizza Hut
- Raising Cane's
- Sam's Club
- Subway
- Whataburger

**Revised: 2-11-22**

**ORDINANCE NO. 6198 OF 2022**

BY THE CADDO PARISH COMMISSION:

**AN ORDINANCE AMENDING THE BUDGET OF ESTIMATED REVENUES AND EXPENDITURES FOR THE RIVERBOAT FUND FOR THE YEAR 2022 TO PROVIDE AN ADDITIONAL APPROPRIATION OF \$15,000 FOR ROBINSON'S RESCUE AND TO OTHERWISE PROVIDE WITH RESPECT THERETO**

WHEREAS, the Non-Governmental Organizations Committee of the Caddo Parish Commission recommended the Commission provide an appropriation of an additional \$15,000 for Robinson's Rescue; and

WHEREAS, the mission of Robinson's Rescue is to eliminate euthanasia of dogs and cats in Northwest Louisiana via an aggressive, comprehensive spay and neuter program; and

WHEREAS, Robinson's Rescue, since its inception, has partnered with the Caddo Parish Commission to provide low cost, high quality spay and neuter surgeries for pets belonging to citizens of Caddo Parish; and

WHEREAS, Robinson's Rescue's 2022 appropriation is \$35,000, a reduction of \$15,000 from the 2020 appropriation; and

WHEREAS, the NGO Committee recommends increasing Robinson's Rescue's 2022 appropriation from \$35,000 to \$50,000; and

WHEREAS it is necessary to amend the 2022 Budget to provide an additional appropriation of \$15,000 for Robinson's Rescue; and

NOW, THEREFORE, BE IT ORDAINED, by the Caddo Parish Commission in due, legal and regular session convened, that Budget of Estimated Revenues and Expenditures for the Riverboat Fund for the year 2022 is hereby amended as follows:

	<u>Budget Increase (Decrease)</u>
<u>Riverboat Fund</u>	
NGO Appropriations – Robinson's Rescue	\$15,000
Fund Balance	(\$15,000)

BE IT FURTHER ORDAINED, that if any provision or item of this ordinance or the application thereof is held invalid, such invalidity shall not affect other provisions, items or applications which can be given effect without the invalid provisions, items or applications, and to this end the provisions of this ordinance are hereby declared severable.

BE IT FURTHER ORDAINED, that this ordinance shall take effect upon adoption.

BE IT FURTHER ORDAINED, that all ordinances or parts thereof in conflict herewith are hereby repealed.

Approved as to legal form:

\_\_\_\_\_  
Parish Attorney

\_\_\_\_\_  
Date



**ORDINANCE NO. 6199 OF 2022**

BY THE CADDO PARISH COMMISSION:

**AN ORDINANCE AMENDING THE BUDGET OF ESTIMATED REVENUES AND EXPENDITURES FOR THE RIVERBOAT FUND FOR THE YEAR 2022 TO PROVIDE AN APPROPRIATION TO PROVIDE BALLISTIC VESTS FOR SHREVEPORT AND CADDO PARISH FIRE DISTRICTS, AND TO OTHERWISE PROVIDE WITH RESPECT THERETO**

WHEREAS, the local fire departments are called to most all emergencies in the community many of which that do not involve a fire; and

WHEREAS, many of these emergencies are to rescue or assist victims or violence, including shootings; and

WHEREAS, local police officers are equipped ballistic vest; and

WHEREAS, local fire fighters are not equipped with ballistic vest; and

WHEREAS, many of the fire districts do not have the funds to pay for this type equipment and the Fire Districts are seeking assistance from the Caddo Parish Commission to purchase ballistic vest; and

WHEREAS, the Caddo Parish Commission originally appropriated funds for the ballistic vest with Ordinance 6109 of 2021; and

WHEREAS, the original appropriation lapsed and needs to be re-appropriated; and

WHEREAS, the Caddo Parish Commission would like to appropriate funds to purchase ballistic vest for our local Shreveport and Caddo Fire Districts; and

NOW, THEREFORE, BE IT ORDAINED, by the Caddo Parish Commission in due, legal and regular session convened, that Budget of Estimated Revenues and Expenditures for the Riverboat Fund for the year 2022 is hereby amended as follows:

	<u>Budget Increase (Decrease)</u>
<b>Riverboat Fund</b>	
Allocations to Other Entities	
Fire Districts – Ballistic Vest	\$130,700
Fund Balance	\$(130,700)

BE IT FURTHER ORDAINED, that if any provision or item of this ordinance or the application thereof is held invalid, such invalidity shall not affect other provisions, items or applications which can be given effect without the invalid provisions, items or applications, and to this end the provisions of this ordinance are hereby declared severable.

BE IT FURTHER ORDAINED, that this ordinance shall take effect upon adoption.

BE IT FURTHER ORDAINED, that all ordinances or parts thereof in conflict herewith are hereby repealed.

**Approved as to legal form:**

**Parish Attorney**

**Date**

**ORDINANCE AND RESOLUTION FACT SHEET**

**CADDO PARISH COMMISSION**

**TITLE**

ORDINANCE AMENDING THE 2022 BUDGET OF ESTIMATED REVENUES AND EXPENDITURES FOR THE RIVERBOAT FUND TO APPROPRIATE \$130,696 FOR BALLISTIC VEST FOR FIREMEN

**(Ordinance No. 6199 of 2022)**

**ORIGINATING DEPARTMENT: Commissioner Taliaferro**

**BACKGROUND INFORMATION:** Amending the budget of Estimated Revenues and Expenditures for the Riverboat Fund for an appropriation for ballistic vest for fireman.

Re-appropriation of funds that lapsed.

Original ordinance was for \$165,300 for 172 vests.

This ordinance is for \$130,700 for 136 vests. 36 vests were purchased when the new fire trucks were purchased.

**KEY STAFF CONTACT:** Hayley Barnett

**AUTHORIZATION**

Department Head

Hayley B Barnett

Date 2/10/22

Legal

\_\_\_\_\_

Date \_\_\_\_\_

Parish Administrator

\_\_\_\_\_

Date \_\_\_\_\_

**ORDINANCE NO. 6200 of 2022**

BY THE CADDO PARISH COMMISSION:

AN ORDINANCE TO ESTABLISH A TEMPORARY PARISH PLANNING AND ZONING COMMISSION, TO PROVIDE FOR ITS MEMBERSHIP, TO PROVIDE FOR AN EFFECTIVE DATE, AND TO OTHERWISE PROVIDE WITH RESPECT THERETO

WHEREAS, Act 294 of 2020 removed Caddo Parish from the Shreveport Caddo Metropolitan Planning Commission effective January 1, 2022;

WHEREAS, Article VI, Section 17 authorizes local governments to adopt regulations for land use and zoning;

WHEREAS, that section also authorizes creation of commissions to implement those regulations;

WHEREAS, Article VI, Section 5 provides for the adoption of home rule charters by local governments and the exercise by such home rule charter governments of all powers and functions not denied them by the constitution or by general state law and of all powers and functions granted to local governmental subdivisions by other provisions of the Constitution;

WHEREAS, the state statutes regarding planning and zoning by local governments provide for the establishment of a planning and zoning commission with between *five* and nine members;

WHEREAS, populating the planning and zoning commission established by the Caddo Parish Commission via Ordinance 6071 of 2022 has stalled pending a requested Attorney General's opinion on the matter;

WHEREAS, not having a parish planning and zoning commission has resulted in delays in all forms of development which require planning and zoning recommendation and approval;

WHEREAS, the Caddo Parish Commission wishes to provide a temporary process wherein development can proceed until it makes a permanent decision on populating the planning and zoning commission created via Ordinance 6071 of 2021;

NOW, THEREFORE, BE IT ORDAINED, by the Caddo Parish Commission in due, legal and regular session convened, that a temporary Caddo Parish Planning and Zoning Commission is hereby created as provided herein.

BE IT FURTHER ORDAINED, that the Caddo Parish Planning Commission shall consist of five members selected from the names that have been submitted to the Caddo Parish Commission as of February 14, 2022. The Parish Commission may only remove any member of the temporary commission, after public hearing, for inefficiency, neglect of duty, or malfeasance in office. The Temporary Caddo Parish Planning Commission may by rule or bylaw provide for such officers and establish such rules and procedures as it deems appropriate.

BE IT FURTHER ORDAINED, that the Temporary Caddo Parish Planning and Zoning Commission shall be created and be in existence as of March 3, 2022 and shall exist until June 30, 2022. The Temporary Commission shall hear all planning and zoning matters and make recommendations to the Caddo Parish Commission as all current zoning ordinances require, and shall assume all duties and authority as provided by state law of a planning and zoning commission.

BE IT FURTHER ORDAINED, that if any provision or item of this ordinance or the application thereof is held invalid, such invalidity shall not affect other provisions, items or applications which can be given effect without the invalid provisions, items or applications, and to this end the provisions of this ordinance are hereby declared severable.

BE IT FURTHER ORDAINED, that this ordinance shall take effect upon adoption.

BE IT FURTHER ORDAINED, that all ordinances or parts thereof in conflict herewith, are hereby repealed.

Approved as to legal form:

---

Parish Attorney

---

Date

**ORDINANCE AND RESOLUTION FACT SHEET**

**CADDO PARISH COMMISSION**

TITLE	
Ordinance No. 6200 of 2022	
<p>A AN ORDINANCE TO ESTABLISH A TEMPORARY PARISH PLANNING AND ZONING COMMISSION, TO PROVIDE FOR ITS MEMBERSHIP, TO PROVIDE FOR AN EFFECTIVE DATE, AND TOOTHERWISE PROVIDE WITH RESPECT THERETO</p>	
DATE 2/14/2021	ORIGINATING DEPARTMENT: Legal for Commissioners Chavez and Johnson
<b>BACKGROUND INFORMATION</b>	
<p>There is currently a backlog of zoning permits and approvals because Caddo Parish has not put its planning and zoning board in place, pending an Attorney General opinion on the process that must be followed now that the parish is no longer part of the MPC. Putting this commission in place temporarily allows matters to be addressed pending receipt of the Attorney General opinion. The temporary commission can be dissolved sooner if the opinion arrives before June 30, 2022.</p>	
<b>FINANCIAL IMPACT AND SOURCE OF FUNDING</b>	
None	
<b>EFFECT(S) OF PROPOSED ACTION</b>	
Places the temporary commission in place to hear back logged cases and allow development in the parish to move forward.	
<b>ALTERNATIVES/STAFF RECOMMENDATION</b>	
Do not place a temporary commission; backlog continues. Staff recommends seating a commission.	
<b>KEY STAFF CONTACT</b>	
Donna Frazier, Parish Attorney	
<b>COORDINATION</b>	
Department Head	(Initial) <i>Dys</i>
Parish Attorney	(Initial) <i>Dys</i>
Parish Administrator/CEO	(Initial) <i>WJ</i>

**ORDINANCE NO. 6202 of 2022**

BY THE CADDO PARISH COMMISSION:

AN ORDINANCE TO AUTHORIZE THE ADMINISTRATOR TO EXECUTE AN PREDIAL SERVITUDE OF PASSAGE AND RIGHT TO USE OVER PARISH PROPERTY LOCATED IN SOUTHWESTERN QUARTER OF SECTION 28, TOWNSHIP 22 NORTH RANGE 16 WEST AND TO OTHERWISE PROVIDE WITH RESPECT THERETO.

WHEREAS, the Parish of Caddo has received a request to grant to Philip Blakeman as the owner of landlocked property adjacent to parish property a right of way on the western edge of the Old Vivian Landfill property.

WHEREAS, the Parish of Caddo has reviewed the request and determined it is in the best interest of the Parish of Caddo to approve said request.

WHEREAS, Philip Blakeman has agreed to pay the Parish for the granting of the servitude of passage as depicted on the plat attached as Exhibit "A"

NOW, THEREFORE, BE IT ORDAINED, by the Caddo Parish Commission in due, legal and regular session convened, that the Parish Administrator or his designated representative shall be and is hereby, authorized to execute an predial servitude of passage and right to use over a portion of the Old Vivian Landfill property as depicted in Exhibit "A" for the purposes of ingress and egress to landlocked property adjacent to parish property.

BE IT FURTHER ORDAINED, that if any provision or item of this ordinance or the application thereof is held invalid, such invalidity shall not affect other provisions, items or applications which can be given effect without the invalid provisions, items or applications, and to this end the provisions of this ordinance are hereby declared severable.

BE IT FURTHER ORDAINED, that this ordinance shall take effect upon adoption.

BE IT FURTHER ORDAINED, that all ordinances or parts thereof in conflict herewith are hereby repealed.

**Approved as to legal form:**

\_\_\_\_\_  
**Parish Attorney**

\_\_\_\_\_  
**Date**

**ORDINANCE FACT SHEET  
CADDO PARISH COMMISSION**

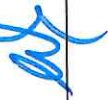
<p>Ordinance 6202 of 2022</p>	<p><b>TITLE</b></p>	<p>AN ORDINANCE TO AUTHORIZE THE ADMINISTRATOR TO EXECUTE AN PREDIAL SERVITUDE OF PASSAGE AND RIGHT TO USE OVER PARISH PROPERTY LOCATED IN SOUTHWESTERN QUARTER OF SECTION 28, TOWNSHIP 22 NORTH RANGE 16 WEST AND TO OTHERWISE PROVIDE WITH RESPECT THERETO</p>
<p><b>DATE:</b> February 10, 2022</p>	<p><b>ORIGINATING DEPARTMENT:</b> Legal for Public Works</p>	
<p><b>BACKGROUND INFORMATION</b></p>		
<p>Philip Blakeman is the owner of 80 acres of land in the West half of the Northwest Quarter Section 33. Township 22 North, Range 16 West, Caddo Parish, Louisiana. That tract is landlocked and does not have access to a public road. Under the law, he is entitled to a right of passage over neighboring property to a public road. The Parish is willing to grant him that a 30 foot right of way on the west side of the Old Vivian Landfill tract. He has agreed to install fencing along the right of way and install drains as stipulated by Dept. of Public Works across any road he constructs. Additionally, he has agreed to compensate the Parish for that right of way/right of passage.</p>		
<p><b>FINANCIAL IMPACT AND SOURCE OF FUNDING</b></p>		
<p>There is no financial impact to the Parish as Philip Blakeman will pay the Parish for the right of passage.</p>		
<p><b>EFFECT(S) OF PROPOSED ACTION</b></p>		
<p>The grant of the right of passage will create a road along the west edge of the Parish's property. This will not interfere with the Parish's use of the remainder of the property.</p>		
<p><b>ALTERNATIVES/STAFF RECOMMENDATION</b></p>		
<p>Refuse to grant the right of passage and force the owner to sue the Parish for what he is legally entitled to have. Staff recommends granting the right of passage/right of way.</p>		
<p><b>KEY STAFF CONTACT</b></p>		
<p>Henry M. Bernstein, Assistant Parish Attorney; Jimmy Whittington, Public Works</p>		
<p><b>COORDINATION</b></p>		
<p>Department Head</p>		<p>(Initial) <i>HW</i></p>
<p>Parish Administrator/CEO</p>		<p>(Initial) <i>aj</i></p>

**NORTHWESTERN LAND DISTRICT**  
LOUISIANA MERIDIAN

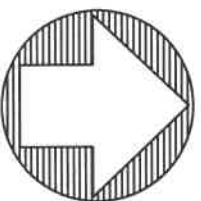

**NORTH**



CADDO PARISH ROAD 154  
(VIVIAN AIRPORT ROAD)  
FND. 3/4" IRON PIPE  
FND. 1/2" IRON ROD

OWNER:  
WILLIE DANIELS, JR.

OWNER:  
E.H. WHITE  
LAND &  
TIMBER CO., LLC

N02°03'07"E 1913.14'  
S02°03'07"W 1907.55'

OWNER: CADDO PARISH COMMISSION

**30' WIDE SERVITUDE**

**OF PASSAGE**

1.316 ACRES



POINT OF BEGINNING  
FND. 5/8" IRON ROD

S29 S32 S33  
T22N-R16W  
N89°38'21"W 30.01'  
OWNER: PHILLIP BLAKEMAN

- NOTES:
1. BEARINGS ARE GRID, STATE PLANE, LOUISIANA NORTH ZONE, NAD83 AS OBTAINED BY GPS OBSERVATIONS UTILIZING THE CAGNET NRTK.
  2. OWNERSHIP INFORMATION SHOWN HEREON IS BASED SOLELY UPON INFORMATION FROM THE CADDO PARISH TAX ASSESSOR WEBSITE.
  3. THIS SURVEY DOES NOT CONSTITUTE A TITLE SEARCH BY THE SURVEYOR. THIS SURVEY WAS MADE WITHOUT THE BENEFIT OF A TITLE COMMITMENT. SURVEYOR HAS NOT MADE ANY INVESTIGATIVE SEARCH FOR TITLE EVIDENCE, ENCUMBRANCES, SERVITUDES, RESTRICTIVE COVENANTS, LIENS OR ANY OTHER FACT THAT A CURRENT TITLE SEARCH MAY DISCLOSE.
  4. ANY UTILITIES AND/OR ADDITIONAL SERVITUDES THAT MAY EXIST WITHIN THIS PROPERTY ARE NOT SHOWN HEREON.

**LEGAL DESCRIPTION FOR A 30' WIDE SERVITUDE OF PASSAGE:**

A 30' WIDE SERVITUDE OF PASSAGE ACROSS THE SOUTHWEST QUARTER OF SECTION 28, LYING EAST OF AND ADJACENT TO THE COMMON LINE BETWEEN SECTIONS 29 AND 28, EXTENDING SOUTHERLY FROM THE SOUTH RIGHT OF WAY LINE OF VIVIAN AIRPORT ROAD TO THE NORTH LINE OF SECTION 33, ALL IN TOWNSHIP 22 NORTH, RANGE 16 WEST, CADDO PARISH, LOUISIANA, SAID SERVITUDE BEING MORE PARTICULARLY DESCRIBED AS FOLLOWS:

BEGIN AT A 5/8" IRON ROD AT THE CORNER COMMON TO SECTIONS 28, 29, 32 AND 33, TOWNSHIP 22 NORTH, RANGE 16 WEST, CADDO PARISH, LOUISIANA, BEING THE POINT OF BEGINNING OF THE TRACT HEREIN DESCRIBED:

THENCE NORTH 02°03'07" EAST A DISTANCE OF 1,913.14 FEET ALONG THE COMMON LINE BETWEEN SAID SECTIONS 28 AND 29 TO THE SOUTH RIGHT OF WAY LINE OF PARISH ROAD 154 (VIVIAN AIRPORT ROAD);

THENCE SOUTH 79°02'21" EAST A DISTANCE OF 30.37 FEET ALONG SAID SOUTH RIGHT OF WAY LINE;

THENCE SOUTH 02°03'07" WEST A DISTANCE OF 1907.55 FEET TO THE COMMON LINE BETWEEN SAID SECTION 28 AND 33;

THENCE NORTH 89°38'21" WEST A DISTANCE OF 30.01 FEET ALONG SAID COMMON LINE TO THE POINT OF BEGINNING.

SAID 30' WIDE SERVITUDE OF PASSAGE HEREIN DESCRIBED CONTAINING 57,310 SQUARE FEET OR 1.316 ACRES, MORE OR LESS.

I certify that this map represents an actual ground survey prepared under my direct supervision in accordance with the applicable La. standards of practice for a route survey.

**MOHR AND ASSOCIATES, INC.** Date  
Johnnie A. Craig  
Registered Professional Land Surveyor  
Registration No. 4587

*Johnnie A. Craig*  
1-29-21



**Mohr and Associates, Inc.**  
Consulting Civil Engineers & Land Surveyors  
1324 N. Hearne Ave., Ste 301 Phone: (318) 686-7190  
Shreveport, Louisiana 71107 Fax: (318) 402-4400

FOR:	Phillip Blakeman
Proposed Servitude of Passage	
Date	1-27-2021
Job	37866
Scale	1"=200'
Drawn	B. ANDERSON

1/29/2021 8:12:45 AM V:\SURVEYS\BLAKEMAN, PHILLIP\DRAWINGS\37866-BMAP.DWG

**ORDINANCE NO. 6203 of 2022**

BY THE CADDO PARISH COMMISSION:

AN ORDINANCE TO AUTHORIZE THE ADMINISTRATOR TO EXECUTE AN EASEMENT AND RIGHT-OF-WAY AGREEMENT WITH CADDEAUX GATHERING, LLC REGARDING A PIPELINE THROUGH AND UNDER PARISH PROPERTY LOCATED IN SECTION 7, TOWNSHIP 18 NORTH, RANGE 15 WEST, CADDO PARISH, LOUISIANA, AND TO OTHERWISE PROVIDE WITH RESPECT THERETO.

WHEREAS, the Parish of Caddo had received a request to grant to Caddeaux Gathering, LLC a permanent easement and right-of-way (as depicted on Exhibit "A") in Section 7, Township 18 North, Range 15 West, Caddo Parish, Louisiana to install a pipeline for the transportation of oil, natural gas, other gases, liquids, hydrocarbons or mixtures of the foregoing;

WHEREAS, the pipeline will be installed entirely by subsurface boring which means that the surface of the property will remain undisturbed;

WHEREAS, the Parish of Caddo has reviewed the request and determined it is in the best interest of the Parish of Caddo to approve said request;

WHEREAS, Caddeaux Gathering, LLC has agreed to pay the Parish for the easement and right of way; and

WHEREAS, Caddeaux Gathering, LLC has provided the Parish with a plat showing the final location of the easement and right-of-way which is attached as Exhibit A.

NOW, THEREFORE, BE IT ORDAINED, by the Caddo Parish Commission in due, legal and regular session convened, that the Parish Administrator or his designated representative shall be and is hereby, authorized to execute an easement and right-of-way for the installation of a pipeline as depicted on Exhibit "A".

BE IT FURTHER ORDAINED, that if any provision or item of this ordinance or the application thereof is held invalid, such invalidity shall not affect other provisions, items or applications which can be given effect without the invalid provisions, items or applications, and to this end the provisions of this ordinance are hereby declared severable.

BE IT FURTHER ORDAINED, that this ordinance shall take effect upon adoption.

BE IT FURTHER ORDAINED, that all ordinances or parts thereof in conflict herewith are hereby repealed.

**Approved as to legal form:**

\_\_\_\_\_  
**Parish Attorney**

\_\_\_\_\_  
**Date**

**ORDINANCE FACT SHEET  
CADDO PARISH COMMISSION**

<b>TITLE</b>	Ordinance 6203 of 2022
	AN ORDINANCE TO AUTHORIZE THE ADMINISTRATOR TO EXECUTE AN EASEMENT AND RIGHT-OF-WAY AGREEMENT WITH CADDEAUX GATHERING, LLC REGARDING A PIPELINE THROUGH AND UNDER PARISH PROPERTY LOCATED IN SECTION 7, TOWNSHIP 18 NORTH, RANGE 15 WEST, CADDO PARISH, LOUISIANA,
<b>DATE:</b> February 10, 2022	<b>ORIGINATING DEPARTMENT:</b> Legal for Public Works
<b>BACKGROUND INFORMATION</b>	Caddeaux Gathering LLC has requested that the Parish grant it a pipeline servitude under a 2.5 acre tract of Parish property located just off Backpath Road south of Blanchard Furrh Road. The pipeline will be installed entirely by boring and not by open trenching such that the surface of the property will not be disturbed. The Parish property is not used for any purpose and is not adjacent to any other Parish property.
<b>FINANCIAL IMPACT AND SOURCE OF FUNDING</b>	No financial impact as the pipeline company will pay the Parish \$400 per rod for the servitude.
<b>EFFECT(S) OF PROPOSED ACTION</b>	Granting the servitude will provide the pipeline company with a means to install a pipeline. The restriction of not trenching will mean that the surface of the property will not be disturbed.
<b>ALTERNATIVES/STAFF RECOMMENDATION</b>	The alternative is to refuse to grant the servitude. Staff recommendation is to grant the servitude.
<b>KEY STAFF CONTACT</b>	Henry M Bernstein, Assistant Parish Attorney; Jimmy Whittington, Dept. of Public Works
<b>COORDINATION</b>	
Department Head	 (Initial) <b>NMB</b>
Parish Administrator/CEO	(Initial) <b>ak</b>

# EXHIBIT "A"

## CADDO PARISH, LA

### SECTION 7, T18N-R15W

### LOUISIANA MERIDIAN

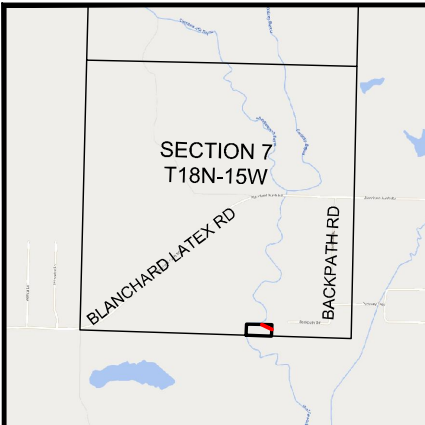

VICINITY MAP  
N.T.S.

LA-CD-CY-003.000  
KEN LAWLER BUILDERS, INC.  
DOCUMENT # 1554274  
C.R.C.P.L.

LA-CD-CY-002.000  
PARISH OF CADDO  
TRACT A  
DOCUMENT # 1622483  
C.R.C.P.L.

LA-CD-CY-001.000  
STEVEN N. STEPHENS  
BOOK 3577 PAGE 273  
C.R.C.P.L.

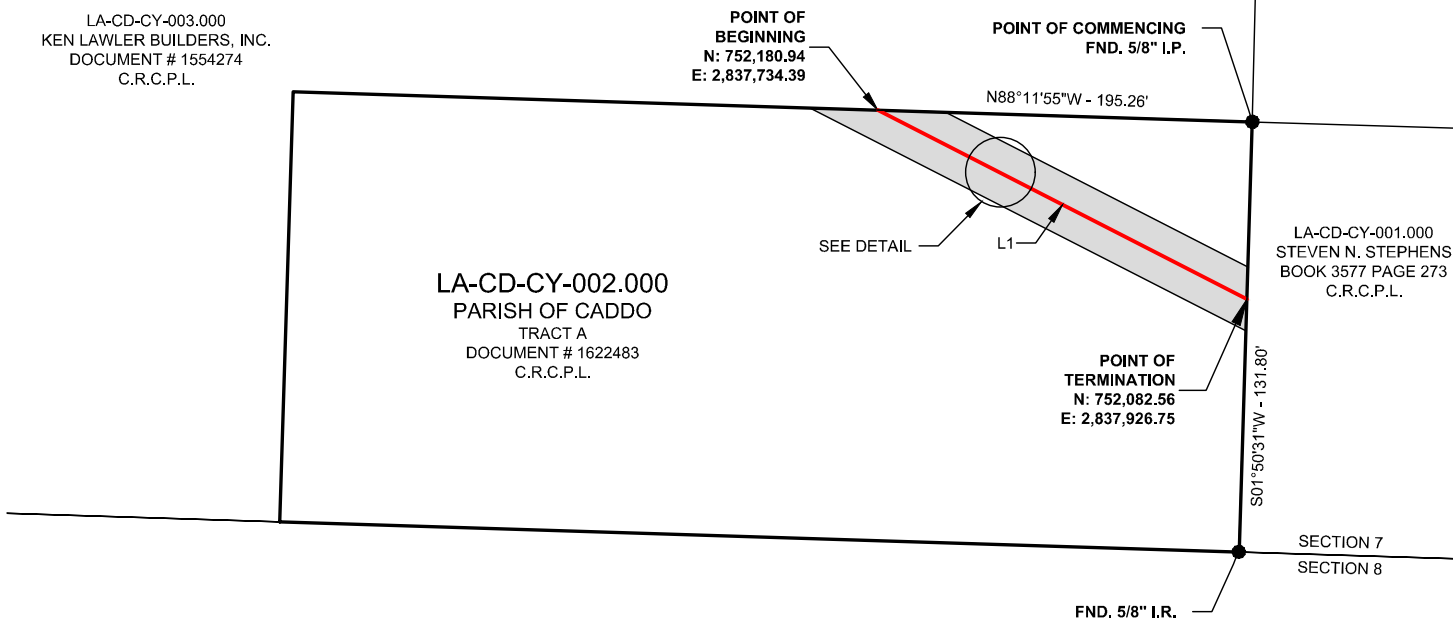
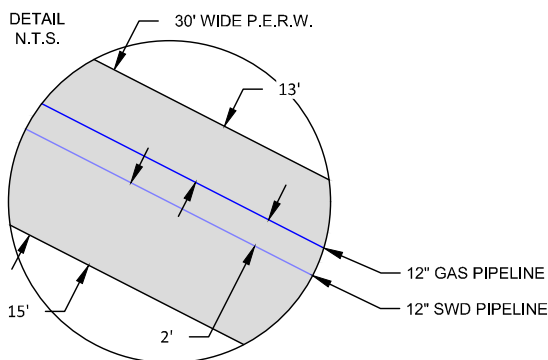

Line Table		
Line #	Direction	Length
L1	S62° 54' 50"E	216.06

TOTAL AREA OF P.E.R.W.: 0.15 ACRES  
TOTAL AREA OF T.W.S.: 0.00 ACRES  
TOTAL AREA OF A.T.W.S.: 0.00 ACRES

TOTAL DISTANCE BASELINE ACROSS PROPERTY: 216.06 FEET  
OR: 13.09 RODS  
TOTAL DISTANCE PROPOSED 12" GAS PIPELINE ACROSS PROPERTY: 210.87 FEET  
OR: 12.78 RODS  
TOTAL DISTANCE PROPOSED 12" SWD PIPELINE ACROSS PROPERTY: 216.06 FEET  
OR: 13.09 RODS

**LEGEND**

- I.R. IRON ROD
- I.P. IRON PIPE
- FND. FOUND
- N.T.S. NOT TO SCALE
- R-O-W RIGHT OF WAY
- C.R.C.P.L. CONVEYANCE RECORDS OF CADDO PARISH, LOUISIANA

- BROKEN LINE NOT SCALABLE
- PROPERTY LINE
- BASELINE
- R-O-W
- PERMANENT EASEMENT HATCH
- TEMPORARY WORKSPACE HATCH (T.W.S.)
- ADDITIONAL TEMPORARY WORKSPACE HATCH (A.T.W.S.)

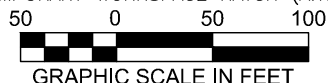

**NOTES**

- ALL BEARINGS, DISTANCES, AND COORDINATES SHOWN HEREIN ARE GRID, BASED UPON THE LOUISIANA COORDINATE SYSTEM, LOUISIANA NORTH ZONE, NORTH AMERICAN DATUM OF 1983 [NAD83(2011)(EPOCH:2010.0000)], U.S. SURVEY FEET, AS DERIVED FROM AN ON THE GROUND SURVEY PERFORMED BY ATWELL, LLC IN AUGUST 2021.
- THE TITLE INFORMATION OF THE SUBJECT TRACT, SHOWN HEREIN, IS BASED UPON TITLE RESEARCH CONDUCTED BY ENERGY ACCESS SOLUTIONS. THIS PLAT WAS PREPARED WITHOUT A COMMITMENT FOR TITLE INSURANCE. EASEMENTS OF RECORD MAY EXIST AND ARE NOT SHOWN HEREON. THIS PLAT DOES NOT REPRESENT A BOUNDARY SURVEY.
- FOR REFERENCE AND FURTHER INFORMATION, SEE ATTACHED LEGAL DESCRIPTION.

I, BRADLEY AMES DEMPSTER, PROFESSIONAL LAND SURVEYOR, HEREBY CERTIFY THIS SURVEY WAS PERFORMED UNDER MY DIRECT SUPERVISION AND IT SUBSTANTIALLY CONFORMS TO TITLE 46, PART LXI 2909 FOR ROUTE SURVEYS TO THE BEST OF MY KNOWLEDGE AND BELIEF.

**BRADLEY AMES DEMPSTER**  
License No. 5212  
12/17/2021  
BRADLEY AMES DEMPSTER  
PROFESSIONAL LAND SURVEYOR  
LOUISIANA REGISTRATION NO. 5212



NEXTERA		
DWG BY:	JCH	PROPOSED PIPELINE EASEMENT WITHIN THE PROPERTY OF PARISH OF CADDO
CKD BY:	BAD	
DATE:	10/29/21	
SCALE:	1"=100'	
REV#	DATE	DESCRIPTION
0	10/29/21	CERTIFIED
1	12/16/21	UPDATED FOOTPRINT
DRAWING: 21001030.02-LA-CD-CY-002.000		SHEET NO. 1 OF 2

EXHIBIT "B"

21001030.02  
LA-CD-CY-002.000  
Parish of Caddo

Permanent Easement and Right of Way

STATE OF LOUISIANA  
PARISH OF CADDO

P.E.R.W. CENTERLINE

Centerline description of thirty-foot (30') wide Permanent Easement and Right of Way situated in Section 7, Township 18 North, Range 15 West of the Louisiana Meridian, Caddo Parish, Louisiana and being over, through, and across a tract of land being described by an instrument to Parish of Caddo, recorded under Document # 1622483 of the Conveyance Records of Caddo Parish, Louisiana (C.R.C.P.L.) The sidelines of said thirty-foot (30') Permanent Easement and Right of Way being situated fifteen feet (15') on each side of the herein described baseline, with a proposed 12-inch (12") gas pipeline being offset 13 feet (13') south from the north sideline and a proposed 12-inch (12") saltwater disposal pipeline being situated 15 feet (15') north from the south sideline, said sidelines being lengthened or shortened to meet the boundary lines of said subject tract. (SEE EXHIBIT "A" FOR FURTHER CLARIFICATION). Said baseline being more particularly described as follow:

COMMENCING at a 5/8-inch iron pipe found for the northeast corner of said subject tract.

THENCE, North 88° 11' 55" West along the north line of said subject tract a distance of 195.26 feet to the POINT OF BEGINNING of the herein described baseline description. Said point of Beginning having coordinates of North: 752,180.94 and East: 2,837,734.39.

THENCE the following one (1) call:

- 1) South 62° 54' 50" East, a distance of 216.06 feet to the POINT OF TERMINATION on the east line of subject tract, having coordinates of North: 752,082.56 and East: 2,837,926.75, from which a 5/8-inch iron rod found for the southeast corner of said Subject tract, bears South 01° 50' 31" West, a distance of 131.80 feet on the south line of Section 7.

Said baseline being 216.06 Feet, or 13.09 Rods.  
Area of permanent easement and right-of-way being 0.15 acres.  
Length of said proposed 12" gas pipeline being 210.87 feet, or 12.78 rods.  
Length of said proposed 12" SWD pipeline being 216.06 feet, or 13.09 rods.

All Coordinates, bearings and distances shown herein are grid, based upon Louisiana Coordinate System, Louisiana North Zone, North American Datum of 1983, U.S. Survey Feet, as derived from an on the ground survey performed by Atwell, LLC conducted on August 2021.

For reference and further information see Exhibit "A" drawing number LA-CD-CY-002.000, Revision 1, same date.

BRADLEY AMES DEMPSTER  
License No. 5212  
12/17/2021  
Bradley Ames Dempster  
Professional Land Surveyor  
Registration No. 5212  
Atwell, LLC  
VF # 0000755  
2 Towne Square, Suite 700  
Southfield, MI. 48076

MINUTES OF THE WORK SESSION  
OF THE CADDO PARISH COMMISSION  
HELD ON THE 14<sup>th</sup> DAY OF JANUARY, 2022

The Caddo Parish Commission met in a Work Session, on the above date, at 3:30 p.m., in the Government Chambers, with Mr. Atkins, presiding, and the following members in attendance constituting a quorum: Commissioners Atkins, Chavez, Epperson, Hopkins, Lazarus, Taliaferro, and Young (7). ABSENT: Commissioners Burrell, Gage-Watts, Jackson, Johnson, and Jones (5).

The invocation was given by Mr. Chavez, and Mr. Taliaferro led the Commission in the Pledge of Allegiance.

**CITIZENS COMMENTS**

Ken Krefft came before the Commission and gave the following comment:

I like to come and want to have several things and try to get them all at three minutes, instead of making one trip for every item. Of course, a year ago we had a lot of ice and snow it's so much nicer today. A reminder for Todd's district, and also whoever's got the district at the intersection of I-20 and the state line—as I've mentioned before, going back to 2014 I think, so eight years later? I do it about once a year around my birthday, which was Tuesday a week ago 2/2/22. Let's get 'Welcome to Caddo Parish' on I-20 eastbound coming from Texas. Westbound leaving Bossier, we're welcomed. Let's get a sign, small and inexpensive, 'Welcome to Caddo'. Southbound and I-49, there is none. Welcome to Louisiana—Bienvenu en Louisiana. Northbound and I-49, leaving Desoto, there's a 'Welcome to Caddo' sign. US 80 has one eastbound into Caddo and US 71 has one southbound into Caddo, but let's get an I-49 South and an I-20 East welcoming people to Caddo Parish. They know they're in the great state. But they don't know what Parish they're in when they're not familiar. In the Charter Review Committee, which met not this year, not last year, but before last May—two recommendations. Mrs. Bryant mentioned that the Juvenile Justice meeting on Groundhog Day—they've recently failed. Well, I checked the record, in the 2016 Review Committee made four recommendations voted on in December of 2016. The same year, not two years later. If we wait until 2023 on the two Charter amendments, Fleet Services being one and it almost passed last time—three or four passed last time. Check the record. Check the Secretary of State. Three out of four is majority, and almost all four. We're going to renew, according to Stephanie, some millages that expire at the end of next year. We're going to try this fall, so we're already on the ballot. We're already paying both commissioners and sheriff's deputies. Let's put the two Charter renewal items on the same ballot. They are more likely to pass with tax renewals this year in the fall, than they are next year with a new Juvenile Justice try number five or try number six. We meet tomorrow at Spring Street with Natalie Howell and Casey Jones. Finally, I'm inviting people tomorrow night to the Broadmoor Neighborhood Meeting at 6:30 p.m. at Broadmoor Presbyterian Church Gym. The guest speaker is the new Shreveport Chief of Police, Wayne Smith. The anagram for that is, 'This Way, Men'.

**COMMUNIQUES & COMMITTEE REPORTS**

- Mr. Young asked for an update on the welcome signs for I-49. Mr. Kevin Lawrence, Director for Facilities & Maintenance, said that the contract for the signs should have a purchasing ordered this week. He also mentioned that these are for the signs on I-49 North and I-49 South. the contractor has been given his notice to proceed, but now he's waiting on materials.
- Mr. Epperson requested that a press release be done for the welcome signs for I-49. He also asked that someone empty the flag boxes so he can properly dispose of the flags that are in the box.

**ADMINISTRATOR REPORT**

- Confederate Monument Relocation Update  
Mrs. Bryant said that they have forwarded the contract to the vendor and are waiting to hear back from them and expect to hear something back by tomorrow.
- U.S. Treasury Rental Assistance Program  
Mrs. Bryant said that they are still waiting on the U.S. Treasury. They are hoping to get the funds this week.
- Juvenile Detention  
There are eighteen juveniles in detention and eleven at CCC.  
Mr. Chavez wanted to know why the detention center was a capacity this weekend. Mrs. Bryant mentioned that the number of juveniles in detention is a fluid number. It could be full one day and not full another day, she said. Mr. Clay Walker, Juvenile Services Director, agreed. He also explained that that there were three children who were a part of a recent murder, and they were transferred to CCC. Mr. Chavez requested a yearly snapshot of the percentage of occupants for the year. Mr. Walker said that they normally run about 85% capacity through the year, with an average of nineteen juveniles as the daily population.

Mr. Epperson suggested that the Commissioners read the Op Ed letter that District Attorney James Stewart sent with regards to CCC.

- COVID-19 Infection Data

There have been three positive cases in February, and five within the Parish's agencies. This brings a total of seventy-six cases since July for the Parish.

- Facebook Update

Mrs. Bryant said that they are working through the issues with Facebook, but may need to purchase additional equipment.

### **NEW BUSINESS**

It was **moved by Mr. Hopkins**, seconded by Mr. Lazarus, *that Ordinance No. 6194 of 2022, an ordinance to accept the streets in Old Towne Subdivision Unit 1 into the Parish of Caddo System, and to otherwise provide with respect thereto* be moved to Thursday's agenda for introduction.

Mr. Hopkins explained that these streets meet all the standards to be accepted into the Caddo Parish Road System.

Mr. Young wanted to know why Blanchard was not taking the roads into their system. Mr. Hopkins explains that the Parish maintains all streets except for Vivian and Shreveport.

At this time, Mr. Hopkins' motion carried, as shown by the following roll call votes: AYES: Commissioners Atkins, Chavez, Epperson, Hopkins, Lazarus, Taliaferro, and Young (7). ABSENT: Commissioners Burrell, Gage-Watts, Jackson, Johnson, and Jones (5). NAYS: None (0). ABSTAIN: None (0).

It was **moved by Mr. Hopkins**, seconded by Mr. Lazarus, *that Ordinance No. 6195 of 2022, an ordinance to accept the streets in Blanchard Lake Estates Unit 4 into the Parish of Caddo System, and to otherwise provide with respect thereto* be moved to Thursday's agenda for introduction. Motion carried, as shown by the following roll call votes: AYES: Commissioners Atkins, Chavez, Epperson, Hopkins, Lazarus, Taliaferro, and Young (7). NAYS: None (0). ABSENT: Commissioners Burrell, Gage-Watts, Jackson, Johnson, and Jones (5). ABSTAIN: None (0).

It was **moved by Mr. Young**, seconded by Mr. Hopkins, *that Ordinance No. 6196 of 2022, an ordinance amending the Budget of Estimated Revenues & Expenditures for the American Rescue Plan Fund to provide an appropriation for Juvenile Center in Caddo Parish and to otherwise provide with respect thereto* be moved to Thursday's agenda for introduction. Motion carried, as shown by the following roll call votes: AYES: Commissioners Atkins, Chavez, Epperson, Hopkins, Lazarus, Taliaferro, and Young (7). NAYS: None (0). ABSENT: Commissioners Burrell, Gage-Watts, Jackson, Johnson, and Jones (5). ABSTAIN: None (0).

It was **moved by Mr. Hopkins**, seconded by Mr. Young, *to englobo and move the following ordinances to Thursday's agenda for introduction*

- *Ordinance No. 6197 of 2022, an ordinance amending the Budget of Estimated Revenues & Expenditures for the Riverboat Fund to appropriate funds for the Caddo Parish Grab & Go Feeding Program, and to otherwise provide with respect thereto*
- *Ordinance No. 6198 of 2022, an ordinance amending the Budget of Estimated Revenues & Expenditures for the Riverboat Fund for the year 2022 to provide an additional appropriation of \$15,000 for Robinson's Rescue, and to otherwise provide with respect thereto*

Mr. Hopkins said that both of these recommendations came out of the Appropriations Committee favorably. Mr. Atkins added that both initiatives support the Parish's core underlying mission.

At this time, Mr. Hopkins' motion carried, as shown by the following roll call votes: AYES: Commissioners Atkins, Chavez, Epperson, Hopkins, Lazarus, Taliaferro, and Young (7). NAYS: None (0). ABSENT: Commissioners Burrell, Gage-Watts, Jackson, Johnson, and Jones (5). ABSTAIN: None (0).

It was **moved by Mr. Young**, seconded by Mr. Taliaferro, *that Ordinance No. 6199 of 2022, an ordinance amending the Budget of Estimated Revenues & Expenditures for the Riverboat Fund for the year 2022 to provide an appropriation to provide ballistic vests for Shreveport and Caddo Parish Fire Districts, and to otherwise provide with respect thereto* be moved to Thursday's agenda for introduction. Motion carried, as shown by the following roll call votes: AYES: Commissioners Atkins, Chavez, Epperson, Hopkins, Lazarus, Taliaferro, and Young (7). NAYS: None (0). ABSENT: Commissioners Burrell, Gage-Watts, Jackson, Johnson, and Jones (5). ABSTAIN: None (0).

It was **moved by Mr. Chavez**, seconded by Mr. Young, *that Ordinance No. 6200 of 2022,*

an ordinance to establish a temporary Parish Planning & Zoning Commission, to provide for its membership, to provide for an effective date, and to otherwise provide with respect thereto be moved to Thursday's agenda for introduction.

Mr. Chavez explained that he and Mr. Johnson met with the Shreveport Chamber of Commerce and other local business people and development professionals within the community. They asked that the Parish do something in the interim to expedite the process of those people who sitting in the queue.

Mr. Hopkins said that this does have a sunset, so he will support this legislation.

At this time, Mr. Chavez's motion carried, as shown by the following roll call votes: AYES: Commissioners Atkins, Chavez, Epperson, Hopkins, Lazarus, Taliaferro, and Young (7). NAYS: None (0). ABSENT: Commissioners Burrell, Gage-Watts, Jackson, Johnson, and Jones (5). ABSTAIN: None (0).

It was **moved by Mr. Epperson**, seconded by Mr. Taliaferro, *that Ordinance No. 6201 of 2022, an ordinance amending Ordinance No. 6701 of 2021 to establish a Parish Planning & Zoning Commission, to provide for its membership, to provide for an effective date, and to otherwise provide with respect thereto* be moved to Thursday's agenda for introduction.

Mr. Taliaferro asked for clarification on this legislation. Mr. Epperson explained that this would allow

Mr. Taliaferro suggested that this be delayed until the author of the legislation comes back from NACo.

Mr. Hopkins said that he does not support this legislation. He feels that the members of this board should be in the planning zone. He said that Shreveport, Oil City, Greenwood, etc. have their zoning boards, and this board should be representative of the people who live in the rural areas.

At this time, Mr. Epperson's motion failed, as shown by the following roll call votes: AYES: Commissioners Epperson and Taliaferro (2). NAYS: Commissioners Atkins, Chavez, Hopkins, Lazarus, and Young (5). ABSENT: Commissioners Burrell, Gage-Watts, Jackson, Johnson, and Jones (5). ABSTAIN: None (0).

It was **moved by Mr. Hopkins**, seconded by Mr. Young, *that Ordinance No. 6202 of 2022, an ordinance to authorize the Administrator to execute a predial Servitude of Passage and Right to Use over Parish property located in the southwestern quarter of Section 28, Township 22 North Range 16 West, and to otherwise provide with respect thereto* be moved to Thursday's agenda for introduction.

Mr. Jimmy Whittington, Public Works, explained that this is going to be a servitude over the Old Vivian Landfill. There is a piece of property behind it that is landlocked, and the Parish has to grant access to it.

At this time, Mr. Hopkins' motion carried, as shown by the following roll call votes: AYES: Commissioners Atkins, Chavez, Epperson, Hopkins, Lazarus, Taliaferro, and Young (7). NAYS: None (0). ABSENT: Commissioners Burrell, Gage-Watts, Jackson, Johnson, and Jones (5). ABSTAIN: None (0).

It was **moved by Mr. Hopkins**, seconded by Mr. Lazarus, *that Ordinance No. 6203 of 2022, an ordinance to authorize the Administrator to execute an Easement & Right-Of-Way Agreement with Caddeaux Gathering, LLC regarding a pipeline through and under Parish property located in Section 7, Township 18 North, Range 15 West, Caddo Parish, Louisiana, and to otherwise provide with respect thereto* be moved to Thursday's agenda for introduction.

Mr. Whittington explained that this is for a natural gas pipeline that will be going across a tract of land the Parish owns in the North part of the Parish.

At this time, Mr. Hopkins' motion carried, as shown by the following roll call votes: AYES: Commissioners Atkins, Chavez, Epperson, Hopkins, Lazarus, Taliaferro, and Young (7). NAYS: None (0). ABSENT: Commissioners Burrell, Gage-Watts, Jackson, Johnson, and Jones (5). ABSTAIN: None (0).

It was **moved by Mr. Chavez**, seconded by Mr. Taliaferro, *that Resolution No. 19 of 2022, a resolution amending the Rules & By-Laws of the Caddo Parish Commission regarding the re-submission of agenda items by Commissioners, and otherwise providing with respect thereto* be amended that items shall not be placed on the agenda within one Work Session be moved to Thursday's agenda for consideration.

Mr. Chavez said that this resolution came before the Commission in the recent years. He understands that there are controversial and politically polarized issues, but this legislation allows for a "cool down period" before being brought back up before the full body.

Mr. Hopkins cautioned that this be done carefully. He said that there are some pieces of legislation that need to be acted on quickly because of time sensitivity.

Attorney Frazier wanted to know if this is for the Work Session or the Regular Session. Mr. Chavez said that this would contemplate both situations.

**Substitute motion by Mr. Young**, seconded by Mr. Chavez, *that Resolution No. 19 of 2022* be remanded to the Personnel Policies & Procedures Committee. Motion carried, as shown by the following roll call votes: AYES: Commissioners Atkins, Chavez, Hopkins, Lazarus, Taliaferro, and Young (6). NAYS: Commissioner Epperson (1). ABSENT: Commissioners Burrell, Gage-Watts, Jackson, Johnson, and Jones (5). ABSTAIN: None (0).

It was **moved by Mr. Young**, seconded by Mr. Taliaferro, *that Resolution No. 20 of 2022, a resolution confirming participation in the Louisiana Community Development Block Grant Fiscal Year 2022 Public Facility Improvement Project with Waterworks District No. 7, identifying partners and otherwise providing with respect thereto* be moved to Thursday's agenda for consideration.

Mrs. Hayley Barnett, Finance Director, explained that the Commissioners pick a project every two years for the LCDBG grant process. It is a requirement that the Commission approve a resolution to move forward in the process.

At this time, Mr. Young's motion carried, as shown by the following roll call votes: AYES: Commissioners Atkins, Chavez, Epperson, Hopkins, Lazarus, Taliaferro, and Young (7). NAYS: None (0). ABSENT: Commissioners Burrell, Gage-Watts, Jackson, Johnson, and Jones (5). ABSTAIN: None (0).

It was **moved by Mr. Atkins**, seconded by Mr. Young, *that Special Resolution of Remembrance for Bobbie Cates Hicks* be moved to Thursday's agenda for consideration.

**Substitute motion by Mr. Epperson**, seconded by Mr. Lazarus, *to englobe and move the following items to Thursday's agenda for consideration:*

- *Authorize Special Resolution of Remembrance for Bobbie Cates Hicks*
- *Authorize Special Resolution of Recognition & Appreciation for Chris Thomas*
- *Authorize Hon. James Sims to the Caddo Parish Broadband Committee*

At this time, Mr. Epperson's motion carried, as shown by the following roll call votes: AYES: Commissioners Atkins, Chavez, Epperson, Hopkins, Lazarus, Taliaferro, and Young (7). NAYS: None (0). ABSENT: Commissioners Burrell, Gage-Watts, Jackson, Johnson, and Jones (5). ABSTAIN: None (0).

#### **COMMUNIQUES AND COMMITTEE REPORTS**

- Mr. Chavez announced that the Southern Hills Neighborhood Cleanup was rescheduled to March 5, 2022. He thanked Starbucks and Little Caesars who provide drinks and food for the volunteers.

#### **CONSENT AGENDA**

- *Ordinance No. 6191 of 2022, an ordinance amending the Budget of Estimated Revenues and Expenditures for the Riverboat Fund and Oil and Gas Fund in the amount of \$10,000 to provide an appropriation for the Louisiana Advocates for Immigrants in Detention associated with the Highland Center and to otherwise provide with respect thereto*
- *Ordinance No. 6193 of 2022, an ordinance creating the I-49 North Corridor Economic Development District, State of Louisiana;" defining the boundaries thereof from which area local sales tax, property tax and hotel occupancy tax increments will be determined and used to finance economic development projects in accordance with and as authorized by Part II of Chapter 27 of Title 33 of the Louisiana Revised Statutes of 1950, as amended; and providing for other matters in connection with the foregoing.*

At this time, there was no further discussion to come before the Commission, so the Commission adjourned at 4:13 p.m.

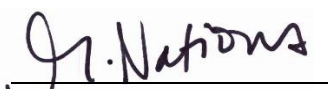
  
Assistant Commission Clerk

MINUTES OF THE WORK SESSION  
OF THE CADDO PARISH COMMISSION  
HELD ON THE 18th DAY OF JANUARY, 2022

The Caddo Parish Commission met in a Work Session, on the above date, at 3:30 p.m., in the Government Chambers, with Mr. Atkins, presiding, and the following members in attendance constituting a quorum: Commissioners Atkins, Burrell, Chavez, Epperson, Gage-Watts, Hopkins, Jackson, Johnson, Jones, Lazarus, Taliaferro, and Young (12). ABSENT: None (0).

The invocation was given by Mr. Jones, and Mr. Chavez led the Commission in the Pledge of Allegiance.

**CITIZENS COMMENTS**

Shirley Pierson came before the Commission and gave the following comment:

I am here representing the School Park Neighborhood Association, which consists of approximately 80 families. The subdivision is located right off Fort Street. So, we travel it daily. We're concerned about the deplorable condition of that street and some sections in particular. It has been disgraceful for a few years now and at the section of the street from Leroy to Dale, the southside lane heading east, is tearing up our vehicles. Some people choose to drive on the other side of the street sometime when, you know, I've seen a few people drive on the other side of the street to avoid the bumps, the potholes, the unevenness of the streets. The humps and bumps in certain sections is really like a roller coaster. So, we have informed City and official Parish officials about the condition of the street and we were told that it is a State Highway. So, it is now our understanding that the State is willing to do improvements after the City of Shreveport does their part; and, I understand that the Parish's involvement is also crucial in getting this done; and, that's why we're before you today. We're asking that you do whatever it takes within your power to fix this problem. Fort street is well travelled. It leads directly to downtown; and, I'm sure you know that the Amazon plant is near that section, so that's going to mean even more traffic. Finally, since I am here today I'd like to thank you, especially Commissioner Jackson, for taking the initiative to name a portion of Ford Street after my husband the late Carl Pierson, who served as a Parish Commissioner for twelve years. So, when we received the notification from the state, my family and I were very elated that Carl would be honored in this manner. So, thank you very much. We hope and pray that you will help in repairing and maintaining Fort Street for the citizens in the Allendale community and for those in other communities who travel it frequently and we thank you again for this opportunity.

Travis Bogan came before the Commission and gave the following comment:

I am here to talk about the Ford Street also. I am a member of the historical Mount Canaan Baptist Church with is located in the Allendale community, and all of our members have to travel Fort Street in order to get to our church services. The condition of the street is really unacceptable. It's really as Mrs. Piercing stated, its not even good for your vehicle to travel. I don't know what the speed limit is it's like one continuous speed bump and I, also, would like to thank Commissioner Jackson for his commitment to doing something; and I encourage all of you to support that effort. Thank you.

Paul Pratt came before the Commission and gave the following comment:

I have rising again in opposition of Resolution 84. That would come before you guys today and on Thursday. You should have a joint letter from LAMOGA, as well as, LOGA in opposition of this resolution also. We see that this resolution is very restrictive and essentially imposes a de facto moratorium on oil and gas drilling. Since, 2014 in Natural gas industry has produced about 5,000 jobs annually in here in Caddo Parish, as well as, \$190M annual payroll. In addition to that, \$100M in severance tax as well as ad valorem taxes to Caddo Parish. Resolution 84 should be-will be restrictive and crippling to our economy, because our oil and gas producers can go across state line to Texas, where they have less restrictive language in their language for rules in their drilling and operating. For example, setbacks. We see that it's proposed 3,000 feet setback. It's not based on any science or any data or current analytics. This is overreaching. As well as, probably the most restrictive setback in the nation. So, we've worked with other communities Desoto Parish, Bossier Parish and come down with common language that makes sense not only for those Parish governments, but also for land owners. There're other things that are also in 84, nighttime completion, which could be problematic for operators; because, it will prolong them drilling as well as fracking. Could increase costs as well as pulling thousands of feet of pipe out of the ground each night. That will be a safety issue for, not only our workers on the forefront, but also our land owners. There are other things that are also mentioned in these twelve provisions of Resolution 84. We see something as significant as a financial surety. That could be very problematic, because of the potential for misuse and all the other provisions and mechanism are already the rules of the state. We ask that you continued to work with the industry as well as department of natural resources to come up with a conservative effort to mitigate noise and dust and all that for the land owners here in Caddo Parish; and I just want you guys to remember one of the reason Caddo Parish is flush with a nice revenue because of the money that you receive from oil and gas exploration about ten years ago. Let's not make these operators go to other areas. Thank you.

Pastor Williams came before the Commission and gave the following comment:

Good afternoon. I am here also in support of Shirley Pierson. I am the Vice President of the School Park Association; and, our concerns are, again, Ford Street. As a lifelong resident of the Allendale/Lakeside community, the neighborhood that I reside in was built in 1962. Therefore, this neighborhood is 59 to 60 years old this year; and, in my lifetime being a residence there, I've never seen Ford Street in such a condition that it is. It is very unsafe to travel. If you don't wear your seatbelt, you will wear it once you come off of Ford Street. I guarantee you. You will end up in the top of your vehicle. It is a very frequent traveled street and I know that you guys will do what is within your power to help us in this situation. There are various churches that are on that street-major churches. As far as, Saint Rest in that area, Mount Canaan, Trinity Baptist Church, and all of these churches use that as an assessment to their property. As well as, going downtown. In fact, there is on the other end of Ford Street, which is Caddo, there is also construction of nice apartments going up; and, I'm quite sure that the people who have the tendency to move in there would not like to have to travel that roller coaster ride in order to get home or away from home. As well as, Amazon being in that area. So, please if you would do what is right in assisting us in getting that corrected. Thank you for your time and your patience.

### VISITORS

- Red River Waterway Commission  
Colin S. Brown  
P.E., Executive Director of Red River Waterway Commission

Mr. Burrell said that they have postponed their visit with the Commission once again. Mr. Jackson and Mr. Young would like to be a part of the discussions with the Red River Waterway Commission.

The Clerk of the Commission mentioned that the Red River Waterway Commission submitted the following letter, which is also attached to the electronic agenda:

*Commissioners,*

*My name is Colin Brown and I am the Executive Director of the Red River Waterway Commission. Thank you for the opportunity to provide a written update on the Red River Waterway Commission. As you well know, we are all living in very challenging times and having to adjust our activities as we continue to deal with the impacts of COVID. I will give you a brief summary of the Commission and recent Commission activities.*

- *The Red River Waterway Commission is the local sponsor of the J. Bennett Johnston Navigation Project, which we all know as, the Red River.*
- *The Red River Navigation Project was authorized by Congress in 1968. The Red River Waterway Commission was created in 1965. Construction began on the Locks and Dams in 1977 with Lock and Dam No. 1 opening in 1984. Locks and Dams 4 and 5 were completed in 1994 making the river fully operational.*
- *The Red River flows for 270 miles in Louisiana. Of that 270 miles, approximately 220 miles are commercially navigable with that portion stretching from the Old River Lock to the Caddo-Bossier Port. It is authorized for a 9' deep by 200' wide navigation channel.*
- *Currently there are 5 locks and dams on the Red River that provide a total lift of 141 feet.*
- *The Red River Waterway District covers a 7-parish area that includes Caddo, Bossier, Red River, Natchitoches, Grant, Rapides, and Avoyelles Parishes.*
- *The Commission is chaired by the Secretary of the Louisiana Department of Transportation and Development, who appoints someone to act in his stead. It is governed by 11 Commissioners appointed by the Governor and confirmed by the Senate. There is one Commissioner from each of the 7 parishes that serve 6-year terms. Additionally, there are 4 At-Large Commissioners that serve terms concurrent with the Governor. As you all know, the Caddo Parish representative on the Commission is Mr. Ronald Lattier and the At-Large Commissioner from Caddo Parish is Mr. Versa Clark.*
- *The Commission, among other things, promotes economic and recreational development along the River.*
- *The Commission, with the Red River as the required nexus, works closely with the 5 public ports on the Red River as part of its economic development role.*
- *The five public ports include the Caddo-Bossier Port, the Red River Parish Port, the Natchitoches Parish Port, the Central Louisiana Regional Port, and the Avoyelles Parish Port.*
- *The Caddo-Bossier Port is the largest of the public ports on the Red River. The Commission currently has three Caddo-Bossier Port projects for which we have budgeted funds including: 1) Heavy Load Multi-Modal Warehouse with RRWC Investment of \$3,435,500, 2) Hardstand/Barge Infrastructure Project with RRWC Investment of \$3,963,650, 3) Slack Water Harbor Dredging Project with RRWC Investment of \$320,000. Recently, the Commission has worked with the Caddo-Bossier Port on completed projects that include: 1) Material Handling Equipment,*

- 2) Warehouse Expansion, 3) Wheel Loader, 4) Dock Fendering System, etc.
- On the recreation side, the Commission owns and operates 19 Recreation Areas. The Commission has 3 Recreation Areas in Caddo Parish - the North Caddo Recreation Area, the Stoner Recreation Area, and the Bishop Point Recreation Area. Combined, these 3 Recreation Areas alone had a 2021 attendance of nearly 240,000 visitors.
- Current Commission projects in Caddo Parish include the Texas Street Bridge Lighting Project with RRWC Investment of \$1,000,000, and the Bishop Point, Red Bayou, and Natchitoches Comfort Station Project with RRWC Investment of approximately \$843,000. Recently completed projects in Caddo Parish include: 1) Stoner/Teague Dock Rehabilitation with RRWC Investment of approximately \$3,000,000, 2) Shreveport Riverview Phase II Project with RRWC Investment of approximately \$1,179,000.
- In a combined economic development/recreation effort, the Commission works with the Shreveport-Bossier Sports Commission to bring fishing events to the Red River. In 2021 the following events occurred in the Caddo Parish area:
  1. The Bass Federations High School State Championship - Economic Impact \$269,622
  2. The Bass Federation National Championship - over 100 anglers from all over the country with an average stay of 7-10 days - Economic Impact \$271,055
  3. Crappie Expo & Mr. Crappie Invitational -The Expo utilized the entire Shreveport Convention Center for 3 days with over 100 vendors. 25,000 visitors attended the Expo over 3 days. Over 200 anglers competed in the event from all over the country. Expo Economic Impact - \$3,739,785, Tournament Economic Impact \$378,162
  4. Kayak Bass Federation National Championship & Expo -The expo was held at the Shreveport Convention Center for 2 days and had over 30 vendors. 350 Anglers competed in the event- Economic Impact \$997,121
- As many of you will recall, the Red River hosted the 2009 and 2012 Bass Master Classics. We continue to seek to have these, and other, tournaments on the Red River.
- In regards to the economic and recreation development on the Red River, a question might be asked as to whether or not the investment in the J. Bennett Johnston Navigation Project is paying off. In that regard, in 2019, the Commission had Dr. Loren Scott complete an update to an Economic Impact Study that was originally prepared in 2006 and updated in 2013. The Economic Impact Study professionally, statistically, and empirically confirms the positive impacts from the Red River. The Red River Waterway Commission, working together with ports and communities along the Red River, has brought over \$10.8 billion dollars to the 7-parish region. As outstanding as that dollar amount is, when adjusted for inflation and put into 2019 dollars, it jumps to almost \$14.4 billion.
- To more easily see the impacts of the Project, for every \$1 of tax collected, over \$36 in new spending, over \$61 in new business sales, and over \$18 in new household earnings has been generated.
- In spite of all of the good news, we face many challenges. One of the major challenges is the reduction in federal funding for channel dredging and backlog maintenance, and for waterways in general. The Commission continues to work closely with the Corps of Engineers regarding these challenges.
- As we move into 2022 and beyond, the Commission will continue to foster economic and recreation development by working with ports and communities on the Red River. New initiatives that the Commission has approved or is considering include the Extension of Navigation into Arkansas and a 12' Navigation Channel on the Red River. These items, if completed, would play a major role in the continued development of the Red River, Caddo Parish, and the entire Red River Waterway District.

Once again, thank you for the opportunity to provide this update on the recent and current activities of the Red River Waterway Commission. Thank you for what you, as Caddo Parish Commissioners, do for Caddo Parish and for our region.

Sincerely,  
/s/Colin S. Brown, P.E.  
Executive Director

- North LA Criminalistics Laboratory  
Teri Pritchard

It was **moved by Mr. Young**, seconded by Mr. Burrell, to move Colin S. Brown as a Visitor to Thursday's agenda. Motion carried by acclamation.

- Put A Poem On It  
Poetic X and Pam Atchison

Poetic X thanked the Commission for appointing him as Poet Laureate for Caddo Parish. He is proposing placing a poem mural in each one of the Commission districts that speaks to the history, neighborhood experiences, etc. that depicts that district.

Ms. Atchison said that even though Poetic X put together a timeline and budget for one year, this might be a two-year project.

Mr. Jackson wanted to know how Poetic X sees how this fit in with the character of the neighborhoods and how he would get students involved. Poetic X said that these murals and poems would motivate, encourage, and even inspire students to get more involved in literacy programs. It is his goal to get as many people as possible to gravitate towards poetry. Poetic X also said that he teaches workshops, so he can help people get their works recorded or published.

Ms. Atchison said that the poem murals would be Poetic X's work, and the QR codes attached to it would be a recording of that poem by Poetic X.

Mr. Young suggested power washing murals.

- Greater Shreveport Chamber of Commerce's Leadership Program  
Kay West

Ms. West said that she was in the 44<sup>th</sup> class for the Leadership Program, and they learned about economic development, transportation, and education. For their class project, they put together a public arts project and would like to partner with the Commission to possibly help fund it.

Mr. Cordavian Baylor said that the objective and goal from the Chamber Class is to communicate the deep desire for positive transformation and continued expansion and growth across this community. The project would be to create a landmark at the Marshall Street underpass, which goes right into downtown. It would be wrapped in colors that would represent the welcoming and encompassing feel and identity and culture of Caddo-Bossier citizens. He also said that the symbol of the butterfly would be incorporated in this project because it represents transformation. It is their goal to work with all community leader in order to communicate and serve as pillars of this community and make this happen.

Mr. Jackson requested that they submit an NGO application for this project. He also said that he is supportive of this project and hopes the Commission will support it as well.

Ms. West mentioned that they do have a budget for \$50,000. She said that the first round of funding came from the City of Shreveport, and they were also able to raise about \$13,000. They are asking the Caddo Commission to match those funds.

Mr. Chavez said that he is in support of this project. He mentioned that his office is adjacent to these pillars. He envisions a quarterly community clean-up with murals across every building. It is his hope to revitalize Marshall Street. He appreciates this team from coming today. Mr. Chavez also wanted to know how artists would participate in this endeavor. Mr. Baylor said that he has been doing public art throughout the City. He also said that he is the lead artist on this project and has two assistant artists, Ben Moss and Eric Francis. Boom lifts are also being acquired for this project since the tallest column is about 38 feet tall.

Mr. Young suggested power washing art. He also suggested this same type of art project on Dalzell Street under I-49.

Mr. Burrell asked Dr. Magner to speak on the Umbrella Broadband Committee.

Dr. Magner explained that the City, Caddo Commission, School Board, Shreve Memorial Library, and the Sheriff's Office got together to discuss developing a coherent broadband plan for this Parish. He also said that there is going to be a significant amount of federal dollars coming this way as a consequence of the bipartisan infrastructure bill that was passed. They want to avoid duplication, so they are looking at ways to create connections between the networks and systems that already exist. Currently, there is an informal collaboration to identify areas where there is either under-capacity or over-capacity in both the City and the Parish. They've also been in contact with the State Broadband Direction and are working with to do try and enable the alignment and integration of funding. Currently, the E-Rate Funding is restrictive in terms of how it can be used to access school and library patrons, but many neighborhoods around those institutions could benefit from Wi-Fi access. They've been successful at working with the schools and the law enforcement agencies to provide access to school cameras for first responders in an active shooter situation. They are hoping to meet again beginning in February to figure out the alignment around the federal dollars.

Mr. Burrell said that the Geaux Grant's deadline was December 31, 2021. He mentioned that the providers have to apply for those monies.

- Community Healthcare Solutions  
Dr. Yolanda Burnom

Dr. Burnom said that pre-pandemic, Community Healthcare Solutions treated over 3,000 clients with intensive services. She explained that clients come in, and they provide intensive services for 14 days, then they are discharged from their program. Of those 3,000 clients, less than 2% returned for additional services or was admitted to an inpatient psychiatric facility or the legal system. During May of 2019, the Department of Health & Hospitals (DHH) and Medicaid came in and wanted to know why Community Healthcare Solutions were sending their clients through crisis services. Dr. Burnom told them that the old way of keeping clients for long-term is a medical model that does not work. After this site visit, Southern Poverty Law Center sued the State of Louisiana for non-existence intensive community-based services. She said that Community Healthcare Solutions is in the process of opening a 24/7 crisis stabilization center called Alternative Interventions. This will be a duplex that can house 8-12 clients up to 14 days, but their goal is to keep them between 5-7 days. It will be staffed 24/7 with a licensed provider, mental health specialist, peer support, and a nurse. They will also have a computer lab and daily activities. They will also offer a mobile crisis van. It is their goal to offer a different solution aside from Brentwood or the Juvenile Detention Center for non-violent crimes. They hope to partner with law enforcement agencies and probations officers to create a test pilot of this model.

Mr. Burrell said that he visited the facility, and this organization is much needed for this community and Parish.

Mr. Jackson pointed out that three different addresses were mentioned. Dr. Burnom explained that the Youree Drive location is for the admin offices, Quentin Street will be where the duplexes are located, and currently, Community Healthcare Solutions is located at 1519 Creswell. Mr. Jackson understood. He is also interested in talking with Dr. Burnom about the medical costs at CCC. He also mentioned to her the empty building that is across the street from CCC.

Mr. Jackson then wanted to know if this facility will be an in-patient facility. Dr. Burnom said that it is not, but an intensive community-based program. It is not their goal to keep clients in treatment for a long period of time.

Mr. Johnson asked that Administration look in to programs that they already have that would fit into Dr. Burnom's program.

- Waste Water Study Update  
Kevin Murnane

Mr. Murnane said that the Parish provided funding for a parish-wide waste water program for community health. This testing is a profoundly useful technology and can detect anything on a community level that a physician can detect from an individual.

Dr. Murnane explained how wastewater testing is a useful technology in public health monitoring as well as detecting COVID viral activity on a community level and that the wastewater testing has the ability to detect coronavirus before someone becomes symptomatic. He further explained that wastewater tests are being used across the country and alerted the Commission that there are reports that Boston's spike in coronavirus was found in their wastewater before the omicron variant reached Massachusetts. Dr. Murnane stated that wastewater tests can also test for methamphetamine, opioids, markers for cardiovascular health, cancer metrics, and any other test similar to what a physician can test. He also stated that the tests are an objective scientific system that could help direct fair and equitable public health decision. Dr. Murnane stated that they have been completing tests for over a year and a half in the City of Shreveport and have found that there are drug prevalence across all communities in Shreveport. Compared to a town in Kentucky that is known for its methamphetamine substance use, their wastewater tests ranged from 200-400 and Shreveport ranged in the 4000s. Dr. Murnane explained that there are drugs in Shreveport's underserved and overserved neighborhoods and that the data from their tests are used in interventions. He stated that they work with the Addiction Center, LSU and the Shreveport Police Department in handling crisis intervention training and de-escalation training in handling excited delirium, an effect of methamphetamine use causing provoked fear. Dr. Murnane also explained that they did not see the spike from the omicron variant due to their sampling schedule and have increased their frequency in testing and sequencing variances. He informed the Commission that they are trying to build a statewide consortium system by expanding into the rural areas of the Parish. They are facing challenges in testing in rural areas, because they are not on the City's water system or use septic tanks. Dr. Murnane stated that they are working with Louisiana Department of Health to create a statewide consortium and are trying to include Tulane, LSU Baton Rouge, University of Louisiana Lafayette, Grambling University, Louisiana Tech University Louisiana, Monroe and Shreveport as well as any other interested partners or universities that were interested. He requested the Commissioners with relationships Shreveport's closest municipalities Oil City, Vivian, Mooringsport, Greenwood, Blanchard and Keithville help facilitate inclusion in the wastewater testing.

Mr. Johnson asked Dr. Murnane if the wastewater plant's aeration pumps that spray mist into the atmosphere are dangerous and spreading the COVID virus to nearby neighborhoods and subdivisions. Dr. Murnane responded that there are small fragments of the virus' DNA strands in the mist that are not living nor can it replicate, reproduce and that is extremely unlikely that it could cause infection. He also stated that the DNA is excreted by people who are infected but are not symptomatic and that excreted DNA can signify the level of infection in a community. Mr. Johnson voiced concern that the wastewater treatment could spray water into the yards and backyards of homes and on people. Dr. Murnane stated that there has not been a recorded circumstance of an infection caused by wastewater mist. Although, he cannot guarantee it won't happen but it is extremely unlikely.

Mr. Young asked how the water is tested from treatment plants and whether those tests can isolate results by neighborhood. Dr. Murnane explained that they gain access to waste water through manholes that they can map the feeder lines that go to through the access point. Then, they go to a lift station to get service from the manhole to the overall system. Mr. Young asked Dr. Murnane for suggestions on possible public health measures could be taken to contain a single, highly infected neighborhood. Dr. Murnane responded that there is heated debate about that and stated that targeted notifications through the City's network in that particular area and increased outreach for vaccinations, social distancing, masking, and other interventions can occur. The issue that is in discussion is for more vigorous interventions. Mr. Young asked if cordoning off a neighborhood is an option. Dr. Murnane stated that they have tried that in South Africa and it did not work at all.

Mr. Burrell expressed excitement for Dr. Murnane's research and how it provides a myriad of significant scientific and unbiased information about neighborhoods. He agreed that being able to identify high drug activity in neighborhoods could help the police department with creating a program to do better.

Mr. Jackson wanted to know if the wastewater testing correlates with testing positive rates and hospitalizations. Dr. Murnane explained that there is a delay between the correlations due to random factors, people who are positive do not get tested or people who are positive with COVID just wait it out and self-quarantine without a follow up test. He also mentioned that reversely the wastewater testing does correlate when infections have increased and decreased in neighborhoods.

#### **ADMINISTRATION REPORT**

- U.S. Treasury Emergency Rental Assistance Program

Mrs. Barnett said that they are currently writing on their last allocation from the Treasury. They were reallocated funds through the State and through the national pool of \$5.2M, but they have not received those funds. They have already allocated approximately \$4M of those funds to be paid out as soon as they are received. The deadline for submitting applications is Wednesday, January 19, 2022. In the event there is a reallocation from Treasury, they will go through the process of reopening the application portal. The Parish of Caddo has distributed approximately \$40M of ERAP funds.

Dr. Wilson commended the Finance Department for all of their hard work in providing the citizens with this funding.

Mr. Jackson asked about Grace Project. Dr. Wilson said that they are lacking in the proper document based on what the Treasury requires. He also said that they have reached out to them in order to obtain that documentation. Dr. Wilson also mentioned that each of the community partners received \$10,000 for startup costs.

Dr. Wilson also pointed out that no customer, of the 14,000 that were served, said they were displeased with any particular organization.

Mrs. Gage-Watts wanted to know who were the attorneys that were helping with eviction mitigation. Attorney Frazier said Jeremy Baybars, Thomas Mayfield, and Alonzo Jackson were, but their contract ended December 31, 2021. She also mentioned that they were not compensated unless they actually assisted someone. Attorney Frazier also said that Alonzo Jackson is still under contract because he has assisted people since December 31, 2021. Mrs. Gage-Watts then wanted to know how many people were helped. Attorney Frazier said that three or four people were assisted. Mrs. Gage-Watts then wanted to know how was this advertised. Attorney Frazier said that it was placed on the website and mentioned in the meetings. She also mentioned that persons who are eligible for assistance with eviction mitigation have to be direct participants.

Mr. Johnson suggested having more advertisement for important issues, such as eviction mitigation. He said that most people don't go to the website. Mrs. Bryant said that they also used social media as a form of advertisement. Mr. Johnson suggested advertising these types of issues on TV.

- Juvenile Detention

There are 21 children in the detention center; six of which are 17 year old, five are OJJ. There are also 8 children in CCC.

Mr. Young asked for an update on what is needed to make conditions for juveniles at CCC more humane and appropriate to their age. Dr. Wilson said that he, Attorney Bernstein, and Mrs. Bryant met with Sheriff Prator, along with their Chief Deputy. The Sheriff's concern was that they are short on personnel, and he had to put the kids into areas where the adults were located. Some of the kids had gang affiliations; when they were left by themselves, they would fight with each other. To manage that, the Sheriff had to split them up. Sheriff Prator said that they are 75 deputies short, so there is a tremendous staffing problem that prohibits him from having a separate area.

Mrs. Gage-Watts wanted to know how many commissioned deputies are at the Caddo Parish Sheriff's Office. Dr. Wilson said that he will find out.

Mr. Johnson wanted to know how many parishes in Louisiana have a detention center. Mr. Clay Walker, Juvenile Services Director, said that there are fourteen centers statewide. Mr. Johnson then wanted to know where do the juveniles go if that parish does not have a facility. Mr. Walker explained that they either go to a place where the Parish rents a bed or in an adult facility for a short period of time. Dr. Wilson said that it has been problematic meeting the State's facility requirements. Mr. Walker said that they did look into how much it would cost to rent beds, and that number came out to be \$2M, which Juvenile Services does not have. He also said that if there is an empty facility, it would need to be staffed. Mr. Johnson then wanted to know if CCC meets the State's guidelines. Mr. Walker said that they do not for juveniles. Dr. Wilson said that those children are there because of the nature of their crimes.

- December, 2021 Financial Report

Dr. Wilson also mentioned that the 2021 December Financial Reports are each Commissioners' station as well as being electronically attached to the agenda.

- Tim James, Inc. and Ford Street Comparison

Dr. Wilson provided copies of this document to the Commissioners, as well as a copy of the Administrator's recommendation regarding Right-Sizing.

Mr. Jackson said that it seems he received a contrast and not a comparison. Dr. Wilson said that he did his best to do a comparison and added that if more is needed, an engineering firm would need to do it.

- COVID

There have been 29 positive COVID cases with the Caddo Parish Commission organization, with 4 contacts. The Clerk of Court's office had three cases; District Attorney's Office had thirteen; Vivian Health Center had two; and the Coroner's Office had two cases.

- Broadband

Mr. Epperson talked about the Broadband Committee. The Clerk of the Commission explained that a Broadband Committee was formed, but there has only been one nomination for the committee. Mr. Epperson said that this is important and is "something that we should get clicking on".

Mr. Burrell mentioned that the Chamber is not "driving the Commission in terms of broadband". He explained that the committee was set up, but he has not heard from anyone, so he reached out to professionals in those areas.

Dr. Wilson said that they submitted three letters of support to internet service providers with regards to the Gumbo Grant to be able to get money to help underserved areas of Caddo Parish or the rural areas.

- Requests from Commissioners

Mrs. Gage-Watts requested an update for COVID testing kits for the citizens. Dr. Wilson said that they requested the kits last week, but have not heard back.

Mr. Epperson talked about orphan wells and mentioned that they are now under the Infrastructure Act. He asked that Administration research it.

Mr. Jackson said that there is a young lady that would like to open an event center on Wells Island Road. He asked that Administration help her resolve this issue.

#### **COMMUNIQUES & COMMITTEE REPORTS**

- Mr. Epperson mentioned that there will be free COVID kits available to citizens. They need to go to [special.usps.com/testkits](https://special.usps.com/testkits). They will be able to receive four kits per household at no cost.

### **PRESIDENT'S REPORT**

Mr. Atkins reminded the Commissioners to submit names to the Clerk of the Commission with regards to the Broadband Committee.

### **OLD BUSINESS**

It was **moved by Mr. Epperson**, seconded by Mr. Hopkins, *that Ordinance No. 6154 of 2022, in regards to Zoning Case 21-35-P, an ordinance to amend Volume II of the Code of Ordinances of the Parish of Caddo, as amended, the Caddo Parish Unified Development Code, by amending the zoning of property located on the west end of Sandi Acres Loop, Caddo Parish, LA, from RMHS, Residential Manufactured Home Subdivision District, to R-A Rural-Agricultural District, and to otherwise provide with respect thereto* be moved to Thursday's agenda for introduction.

Mr. Epperson said that he has not received any complaints or concerns from citizens. He asked that the Commission support this ordinance.

### **NEW BUSINESS**

**Substitute motion by Mr. Jackson**, seconded by Mr. Chavez, *to move the following ordinances to Thursday's agenda for introduction:*

- *Ordinance No. 6154 of 2022, in regards to Zoning Case 21-35-P, an ordinance to amend Volume II of the Code of Ordinances of the Parish of Caddo, as amended, the Caddo Parish Unified Development Code, by amending the zoning of property located on the west end of Sandi Acres Loop, Caddo Parish, LA, from RMHS, Residential Manufactured Home Subdivision District, to R-A Rural-Agricultural District, and to otherwise provide with respect thereto*
- *Ordinance No. 6174 of 2022, an ordinance amending the 2021 Budget to amend the Budget of Estimated Revenues & Expenditures for the Head Start Fund and to otherwise provide with respect thereto*
- *Ordinance No. 6175 of 2022, an ordinance amending the 2021 Budget to amend the Budget of Estimated Revenues & Expenditures for the Section 8 Fund and to otherwise provide with respect thereto*
- *Ordinance No. 6176 of 2022, an ordinance amending the 2021 Budget to amend the Budget of Estimated Revenues & Expenditures for the General Fund to provide an appropriation for the Wheelchair Ramp and Roof Repair Program and to otherwise provide with respect thereto*

Mr. Jackson, Mrs. Gage-Watts, and Mr. Burrell asked to be co-sponsors for Ordinance No. 6176 of 2022.

At this time, Mr. Jackson's substitute motion carried, as shown by the following roll call votes: AYES: Commissioners Atkins, Burrell, Chavez, Epperson, Gage-Watts, Hopkins, Jackson, Jones, Lazarus, Taliaferro, and Young (11). NAYS: None (0). ABSENT: Commissioner Johnson (1). ABSTAIN: None (0).

It was **moved by Mr. Jackson**, seconded by Mr. Burrell, *that Ordinance No. 6177 of 2022, an ordinance amending the Budget of Estimated Revenues & Expenditures for the Oil & Gas Fund and the Riverboat Fund to provide an appropriation of \$32,000 for a mural program and to otherwise provide with respect thereto* be moved to Thursday's agenda for introduction and remanded to the Economic Development Committee for review before final passage. Motion carried, as shown by the following roll call votes: AYES: Commissioners Atkins, Burrell, Chavez, Epperson, Gage-Watts, Hopkins, Jackson, Johnson, Jones, Lazarus, Taliaferro, and Young (12). NAYS: None (0). ABSENT: None (0). ABSTAIN: None (0).

It was **moved by Mr. Jackson**, seconded by Mr. Epperson, *to englobo and move the following items to Thursday's agenda:*

- *Ordinance No. 6178 of 2022, an ordinance to repeal Sections 32-160 through 32-167 of the Caddo Parish Code of Ordinances regarding Noise Violations, and to otherwise provide with respect thereto*
- *Ordinance No. 6179 of 2022, an ordinance to repeal Sections 26-38, Section 26-126, and Sections 26-162 through 26-166 of the Caddo Parish Code of Ordinances regarding Weight Limits, and to otherwise provide with respect thereto*
- *Ordinance No. 6180 of 2022, an ordinance to repeal Chapter 8 of the Caddo Parish*

*Code of Ordinances regarding Animals & Fowl, and to otherwise provide with respect thereto*

- *Ordinance No. 6181 of 2022, an ordinance to repeal Section 12-248 through 12-252 of the Caddo Parish Code of Ordinances regarding Sexually Oriented Businesses, and to otherwise provide with respect thereto*
- *Ordinance No. 6182 of 2022, an ordinance to repeal Chapter 4 of the Caddo parish Code of Ordinances regarding Alcoholic Beverages, and to otherwise provide with respect thereto*
- *Ordinance No. 6183 of 2022, an ordinance to repeal Sections 12-21 through 12-26 of the Caddo Parish Code of Ordinances regarding Occupancy Taxes, and to otherwise provide with respect thereto*
- *Ordinance No. 6184 of 2022, an ordinance to repeal Section 32-115 through 32-118 of the Caddo Parish Code of Ordinances regarding Teen Curfews, and to otherwise provide with respect thereto*
- *Ordinance No. 6185 of 2022, an ordinance to repeal Sections 30-19 through 30-31 and Sections 30-51 through 30-55 of the Caddo Parish Code of Ordinances regarding Property Standards, and to otherwise provide with respect thereto*

Jackson: think some folks have said that I have, you know, tried to slap the fine citizens of the rural areas in the face, which mean I will be slapping my friend Todd Hopkins, and I would dare do that. What I have consistently tried to figure out is what is it that we want, as it relates to zoning regulations, and things of that nature. A lot of us have been some pretty ugly things up here around this issue, and for no reason at all. We've tried to figure out what it is that the rural areas want. I think their Commissioners were on the path to try to figure that out, but we've been bombarded for the last three or four weeks with folks saying they don't want anybody touching their property rights. We've had videos made about us, and they don't want anybody messing with their property rights. At no point did anybody ever tried to make a distinction between property rights and zoning. There has been a mass cadre of folks saying don't mess with my rights. the reality is to say that we're going to live in a society—a lawless society is simply unimaginable and unbelievable. The other thing to me is that we've got a lot of folks who have been quiet on this issue. I got called out by a sector of this community, a business sector of this community for a seconded the motion to move forward the repeal of the UDC. Then I have a developer that is building quarter of million dollar homes in the northern part of the perimeter in my district, call me and chew me out because he said what we're about to do is violate an agreement that he thought he had with local government, which was to build those nice homes with the protection that he would have zoning, which is literally right across the street out in the unincorporated areas of the Parish. I always use Commissioner Gage-Watts for this example. we have a lot of places around here where if we don't have some level of regulation, or rule, we'd have a lawless society but you know, a lot of folks have called me out for introducing this, but I want us to hear what is being said out in the public.

At this time, Mr. Jackson asked that a video be played for the Commission and public to see.

Jackson: Before I put these on the agenda, I questioned whether I should do this. I called the Attorney's Office. I called several folks, and said, 'should I do this?' They were lost on what exactly do we want—or what do the rural residents want. And so you can't say that you want no regulation. You don't want to regulate private property without having any of these as well. So here we are, and I think we need to determine where we want to go.

Johnson: When I first got elected to office, I was getting phone calls, that we had laws on the books that didn't have any teeth to them. And that things weren't happening. The only reason that is even brought in the attention is because we enforced what was on the books. They sent people out to write citations on things that were happening. The UDC had existed for two years, before we send somebody out. We had six months, and I prolonged it in the in the commission, before it even passed—trying to get public input. But they were like, it doesn't bother me, so I'm not worried about. Until we sent officers out and that is when all this happened. So, whether we go back to what we had, until we start putting people out enforcing those laws, they'll be back down here again complaining. But I'm not going to live in a parish where we have no rules because it will get out of hand. I'm not going to support repealing all of this. We need to have at least that in place because that's better than nothing at all. I tried to explain to people that a covenant is good within a neighborhood, but once you go across the street—I can put a dog pound across the street, or I can put a manufacturing plant across the street, and you can't do anything about it, even with all of the pristine covenants you have in your neighborhood. You still want to

know about what's across the street. They don't realize that. Lakeview is one of the worst neighborhoods in the Parish because it has no covenants. So, you have from a single wide trailer to four- or \$5 million-dollar houses all in the same neighborhood. Are you going to turn one way or turn the other way? So that creates a problem. And so, I will not support those, keep those in place until we can come up with something that's better than those, and not as worse as the UDC. When you first saw the UDC, it was ridiculous. You can buy a tract of land, and you cannot cut down all the trees on your own land. I'm not gonna support it, because somebody out their man, they could whatever tree they want down and plant whatever trees they want to play in this place. What I have a problem with one of the groups that came down here that was arguing with us all the time about these laws in place, that property rights, their property rights. Well, they were come to the Commission about property rights, but then going to the City Council and keeping somebody from developing an area right outside of the Cooper Road. You're either for property rights, or you're against property rights. If I own this track land, and you say that you don't want to have no property rights, and do whatever you want to do. But they were being selective. We're going to help support this neighborhood over here, but keep this one from being developed. That's not right. You have to be on one side of the fence or the other. So, with property rights, there are some restrictions that roll with them. They strengthen them some more. And let's move forward instead of doing all of this other stuff.

Young: I just like to point out that the Long-Range Planning Committee appointed a citizens advisory committee to make recommendations about what kind of level of regulation they want in Caddo Parish. All regulations exist within a degree; they're not absolute; none is binary zero or a one. Zoning regulations are the most comprehensive and restrictive form of land use regulations. They are specifically disclaimed as undesirable by the committee and the report that we talked about and was voted on in the Long-Range Planning Committee. That report specifically said that ordinances such as these which are listed for potential repeal, were the level of regulation that they preferred for the place where they live. And so I don't think that claiming to repeal down moves the conversation forward constructively, so I'm gonna vote against it.

Burrell: this kind of thing becomes so political, I guess, just while we in political positions. But at the same time, I'm new to the commission and city ordinances. But as I understood it, even out in the Parish, beyond our city limits, there are regulations. we do have some sort of codes that are out there. I understand that some people did not want the UDC because that was more restrictive than what we already have out there in the rural area. It was my understanding that the MPC said they were modifying those rules that were out in the rural to not make it as astringent as the UDC itself, but a modification of the UDC or the existing rules that are out in the rural. I know he presented a draft to us early on, which almost match what was there originally, they weren't complaining about the rules that were out there before this UDC thing came. I know the MPC director, Alan Clark, did his due diligence to try to modify what was out there by using examples from other rural areas. It appears that they rejected that too. So, I'm back to Commissioner Johnson's statement. Either you want rules or you don't; you can't have it both ways. We need to go back and work with the MPC on getting some sort of modification of what's out there now and to do it so it will be less stringent on the people who are living out there now.

**Call for the Question by Mr. Epperson**, seconded by Mr. Jackson. Motion carried, as shown by the following roll call votes: AYES: Commissioners Atkins, Burrell, Chavez, Epperson, Gage-Watts, Hopkins, Jackson, Johnson, Lazarus, Taliaferro, and Young (11). NAYS: None (0). ABSENT: Commissioner Jones (1). ABSTAIN: None (0).

At this time, Mr. Jackson's motion failed, as shown by the following roll call votes: AYES: Commissioner Epperson (1). NAYS: Commissioners Atkins, Burrell, Chavez, Gage-Watts, Hopkins, Jackson, Johnson, Jones, Lazarus, Taliaferro, and Young (10). None (0). ABSENT: None (0). ABSTAIN: None (0).

It was **moved by Mr. Jackson**, seconded by Mr. Johnson, *to englobo and move the following ordinances to Thursday's agenda for introduction*:

- *Ordinance No. 6186 of 2022, an ordinance amending the Budget of Estimated Revenues & Expenditures for the E. Edward Jones Housing Trust Fund for the year 2022 to appropriate funds received from the U.S. Treasury in the amount of \$5,274,675 for the Emergency Rental Assistance Program and to otherwise provide with respect thereto*
- *Ordinance No. 6187 of 2022, an ordinance amending the Budget of Estimated Revenues & Expenditures for the E. Edward Jones Housing Trust Fund for the year 2021 to appropriate Emergency Rental Assistance Program from the State of Louisiana and to otherwise provide with respect thereto*

At this time, Mr. Jackson's motion carried, as shown by the following roll call votes: AYES: Commissioners Atkins, Burrell, Chavez, Epperson, Gage-Watts, Hopkins, Jackson, Johnson, Jones, Lazarus, Taliaferro, and Young (12). NAYS: None (0). ABSENT: None (0). ABSTAIN: None (0).

It was **moved by Mrs. Gage-Watts**, seconded by Mr. Johnson, *that Ordinance No. 6188 of 2022, an ordinance amending the Budget of Estimated Revenues for the American Rescue Plan Fund to provide an appropriation for Ring Doorbell Pilot Program in Caddo Parish, and to otherwise provide with respect thereto* be moved to Thursday's agenda for introduction.

Mrs. Gage-Watts said that this program is designed to help make the community safer by all by purchasing up to \$100,000 Ring devices for residents in hot-spot areas. The mission is to support residents in these areas that are plagued by gun violence in particular, by providing an additional tool to help fight crime. The participants must be in Caddo parish, as it is stated in the ordinance address is identified in targeted areas. The device will also include one year of paid subscription costs, applicants will receive the devices on a first come first served basis, and they have to be at least 18 years old. They must also agree to register with the Shreveport Crim Center to allow law enforcement to access these devices. They must also own a mobile device and have a Wi-Fi internet connection. There will be a limit to one per household.

Mr. Chavez wanted to know if there would be help to those citizens who do not have internet access. Mrs. Gage-Watts said that there are options such as Internet Essentials with Comcast.

Mr. Chavez also wanted to know how the one-year subscription would be paid. Mrs. Gage-Watts said that the Parish would pay for the one-year subscriptions with Ring.

Mr. Johnson pointed out that this is a pilot program to help gather data to determine if this program should carry on year to year.

Mr. Epperson asked about the cameras that were set up. Mr. Chavez said that those cameras could not be used from the American Rescue Plan Fund. Mr. Johnson said that the purpose would need to be changed.

Mr. Epperson then wanted to know if there are any other communities who are using this program. Mrs. Gage-Watts said that Chicago is using it, and it is a successful program.

Mr. Epperson also wanted to know who would be responsible for damages to the cameras. Mrs. Gage-Watts said that it would be the citizen's device.

Mr. Hopkins wanted to know about the residents in the rural areas of the Parish. Mrs. Gage-Watts said that information would go to the Sheriff's Office.

Mr. Taliaferro wanted to know if we had a deal with Ring. Mrs. Gage-Watts said that the Parish does not.

At this time, Mrs. Gage-Watts' motion carried, as shown by the following roll call votes: AYES: Commissioners Atkins, Burrell, Chavez, Epperson, Gage-Watts, Hopkins, Jackson, Johnson, Jones, Taliaferro, and Young (11). NAYS: None (0). ABSENT: Commissioner Lazarus (1). ABSTAIN: None (0).

It was **moved by Mr. Epperson**, seconded by Mr. Jackson, *that Ordinance No. 6189 of 2022, an ordinance to enact Section 2-5 relative to parish-owned or maintained buildings and offices, to provide that agencies, constitutional officers, or other political subdivisions occupying those buildings and offices shall report data regarding communicable diseases of concern to the public and to otherwise provide with respect thereto* be moved to Thursday's agenda for introduction.

Mr. Epperson said that this information is helpful for citizens to determine whether or not they want to come in-person to these public facilities to handle their business.

Mr. Chavez wanted to know how this information would be distributed to the citizens. Dr. Wilson said that they would need to work out the details on how that would be executed. Mr. Chavez then wanted to know if there would be any incurred fees. Dr. Wilson does not feel that a bill would be associated with this information. Attorney Frazier said that this leads to the question, what would be the enforcement mechanism?

Mr. Epperson wanted to know how they received the information Dr. Wilson provided today with regards to COVID cases. Dr. Wilson said that Human Resources contacted the agencies.

Mr. Atkins wanted to know if there were any issues with invasion of privacy. Dr. Wilson said that they do not disseminate names, only data.

At this time, Mr. Epperson's motion carried, as shown by the following roll call votes: AYES: Commissioners Atkins, Burrell, Chavez, Epperson, Gage-Watts, Hopkins, Jackson, Johnson, Jones, Lazarus, Taliaferro, and Young (12). NAYS: None (0). ABSENT: None (0). ABSTAIN: None (0).

It was **moved by Mr. Young**, seconded by Mr. Taliaferro, *that Resolution No. 9 of 2022, a resolution authorizing the Parish Attorney's Office to request an opinion from the Louisiana State Attorney General's Office reading the authority of the Parish Commission functioning as a Planning & Zoning Commission and otherwise providing with respect thereto* be moved to Thursday's agenda for consideration.

Mr. Young said that LA.R.S. 33:103F states that a Home Ruled Charter Parish may function as its own board, if certain provisions exist in its Charter. He said that they are not sure what specificity those provisions have to have, so an AG opinion is needed.

At this time, Mr. Young's motion carried, as shown by the following roll call votes: AYES: Commissioners Atkins, Burrell, Chavez, Epperson, Gage-Watts, Hopkins, Jackson, Johnson, Jones, Lazarus, Taliaferro, and Young (12). NAYS: None (0). ABSENT: None (0). ABSTAIN: None (0).

It was **moved by Mr. Jackson**, seconded by Mr. Young, *that Resolution No. 10 of 2022, a resolution requiring all ordinances to originate from or be reviewed by Caddo Parish Committees, and otherwise providing with respect thereto* be remanded to the Personnel Policies & Procedures Committee and forward to the January 31, 2022 Work Session.

**Substitute motion by Mr. Chavez**, seconded by Mr. Young, *that Resolution No. 10 of 2022 be remanded to the Personnel Policies & Procedures Committee.*

Mr. Chavez explained that this will go to committee, but regardless of that discussion, it will be back on the agenda for a Work Session.

Mr. Jackson said that he would like this to be vetted in committee, and would like the committee to be called before the next Work Session.

Mr. Chavez withdrew his substitute motion.

At this time, Mr. Jackson's motion carried, as shown by the following roll call votes: AYES: Commissioners Atkins, Burrell, Chavez, Epperson, Gage-Watts, Jackson, Johnson, Jones, Lazarus, Taliaferro, and Young (11). NAYS: None (0). ABSENT: Commissioner Hopkins (1). ABSTAIN: None (0).

It was **moved by Mr. Jackson**, seconded by Mr. Jones, *that Resolution No. 11 of 2022, a resolution urging and requesting the Louisiana Department of Transportation & Development to consider to inclusion of Louisiana Hwy 173, from Pierre Avenue to Hartman Street, in its Right-Sizing Program, and otherwise providing with respect thereto* be moved to Thursday's agenda for consideration.

Kevin Blunck  
DOTD:

The Department has identified a lot of roads in the State System to be what they call right size and that is if any entity would like to receive a road that a state highway that is identified as a right size eligible roadway then the entity can request the state to start process of right sizing. That right sizing means that we bring the road up to a good or better standard—good or better condition in the roadway. Then we give the entity capital outlay credits for 30 years. Caddo Street—I'm sure most of y'all know Caddo for Hwy 173 or Hilary Huckabee. That is a road that has 7,000 cars a day that that drive on a three lane highway. It's a composite roadway. It's got concrete with an asphalt overlay on it. It hasn't been overlaid in quite some time. However, the state is in a in a situation where next year's Pavement Preservation budget is going to be \$6 million. That this district. That's seven parishes. I'm over Caddo and Red River Parish, and I'm basically able to get one road per year overlaid in the Pavement Preservation Program. That means, this year, we're going to get LA 173 up around Oil City up until I-49. Next year, it will be Mansfield Road. However, Ford Street just has to compete with a lot of roads—a lot of bad roads, I guess you could call them. So anyway, it has been discussed over the years that Caddo and Ford and Hilary Huckabee up to I-220 is eligible to be right sized. that's a different program than pavement preservation. If you were to authorize a right size, and we would expect that, that you would authorize it from a state road to a state road. so we've got four options, you've got Spring Street, Market Street, Common, Hearne, and I-220. So if you're talking about right-sizing in front of the Head Start, we would really expect you to go from Hearne to Common, which would be 1.53 miles, and then we would do an overlay, repair any kind of catch basins, and things that were identified. Then you would have to pass another resolution to actually accept the right size. Even though that's up the negotiation and gone through analysis, you get \$2.8 million worth of capital outlay credits.

Tim Weaver  
Public Works:

You know, one of the things on the right size, and there's a big pot of money. Caddo Commission has never wanted to right size. I've talked to Bossier Parish Police Jury, and they haven't right sized because it is a credit. You're getting a road that's heavily traveled. We look for roads that are less traveled. And the main thing with Ford Street is the deal with the limits. I know it's been talked about—you can go from district to district. They like

it to be from state road to state road which encompasses a 380 foot bridge that is 80 feet wide—that was built in 1983. The replacement costs for that is probably 5 to \$8M. It's getting close to 40 years, and I've talked to Kevin—it's a 50 year life on that. That the main deal—it's a big long bridge. It's like when we have to do our swaps with the State. That's the same thing. We look for roads that are not traveled and roads that do not have bridges on it. The other main problem with the road is that it's a city road. Its got city water lines. s on it. The other main problem with the road, it's a city road. It's got city water lines. We've been talking about it for four years that the lines are still leaking to this date. We've had meetings we had a meeting last March with all the players involved. And there's the lines are in front of the Head start; they're still leaking. So we have no control. We can't go work on city water lines. So that's now once the water lines are finished—Kevin has said we would try to get it on the preservation program or, but they're not going to overlay a road that has water leaks on it. So if the city would get their water leaks fixed, I think the road would get overlaid. It has a whole lot of other issues with sidewalks retaining walls, street lights, traffic lights, but it's just very busy road. \$2.8M would not help us replace the bridge that is 10-20 years down the road.

Dr. Wilson: Okay, so and to continue with that, then we'll entertain your questions, Mr. Jackson. The letter I sent to you all relative to this subject was pretty detailed. And there's a difference between a urban roadway system and a Parish roadway system. All of them have drain systems under them, but, you see, on a Parish road is an open ditch system. So, the hydrology is different. When you have a road system within an urban setting, you have a connections of piping under the road, which makes it a force system, and the hydrology is different. That you would have to have the vacuum pump truck to clean out the ditches and things of that nature. So, we don't have the equipment, the manpower, the know-how, to maintain the traffic signal devices on that road. We have 55 lights. We have a forced sewer main system in the center of the road. You have lateral water supply off of the center of the road to going towards the homes on the split side. So, it was just too much for us to take care of and we don't have, as I say, the manpower to put into that. This about using the right tool method for the right job. We haven't looked at the right size program. I had the benefit of being a Public Works Director 16 years ago and it's been around. And it wasn't our strategic manage to take on a road. And the essence of this whole program, that the state was telling us, they have more roads than they can take care of would love someone else to take care of some of the roads that we have to take care of. And then you notice the City just had a bond issue recently, that they were going to go off of a public launch to repair the roads. It'd be a great idea for them to go ahead and right size this road, take to \$2.8 million and repair another City road. We spend an average of \$10 million a year on Parish roads, because we get part of the Parish Road Tax that comes from the state. The Tim James project is going to be 1.6 miles of roads specifically in the Parish designed to state standards. The City will also have to adopt part of that road, too, and to their system. So, there's a difference of apples and oranges here, but the complexity of urban setting we are not equipped to do. That's why I suggested that my-that's not a suggestion-but my recommendation is that we do not go forward with the right sizing of Ford Street and look at other alternative means that we can assist the state and getting this area paved that Commissioner Jackson has pointed out to us. Okay. And, also my closing comments, Miss Pearson. I love you dearly. You and I work together when I was the Director of the Maintenance Department at the school board. We work closely together. Your husband and I, when he was the Director of Athletics at the School Board, we work closely together and he was very instrumental in me being the Administrator today. So, I truly respect you all and no better statesperson to get a street named after him than your-than Mr. Pearson himself. That concludes my comments, sir.

Jackson: Kevin. I heard you say that the state will rebuild this road to good standards by the state measurements. We had a conference call earlier today.

Blunck: Yes. We-right now the 173 is in pavement condition. It's in poor and fair condition. We are proposing that we would bring it up to good or very good pavement standards. With that, that would mean patch and mill and overlay of the road. Now, it has a level of service of low. That means you've got a lot of cars going through, and so, therefore, we do not-with the right sizing-we don't we don't improve the level of service. But, yes, we would spend-the state would spend-money to improve it and it's not coming out of the pavement preservation. So, it wouldn't come out of, you know, the Mansfield Road project or anything. It's got its own separate thing. So.

Jackson: So, and I just want to be very clear, because I heard Dr. Wilson talk about all the structures, all the lights. If we accept the right sizing program that doesn't obligate us to maintain City services, does that?

Blunck: Absolutely not.

Jackson: We don't-

Blunck: We do not maintain them. So, therefore, you would not maintain.

Jackson: We wouldn't have to maintain anything that y'all-

Work Session Minutes  
January 18, 2022

- Blunck: So, in other words, any City street lights, that's the City. Any sidewalks, that's the City. Now, since it is curbs you-we have to, and we would have to do that if we did the overlay. We would have to come in and put handicap ramps on any curb that is not up to handicap standard. Now I know that he was saying, and everybody's saying the state standard. Well, the state standard is the federal standard. And no, we would not-we cannot and we do not on any of our roads-we don't bring on old road up to a 2022 standard. When it-because lane widths, because of total streets, because of control of access, we wouldn't reevaluate every driveway in there. We wouldn't check the lane width to make sure that it's-Up to federal, state standard or to the current standard. But, of course, we're going to-we would make sure that that road is riding with our roughness index. So, it's a smooth road. And of course, once again, with that is whoever takes it-the City, the Caddo, if they do right sizing-they get to negotiate what we're going to do.
- Jackson: So, we wouldn't be boxed into a back, a wall.
- Blunck: Not any-
- Jackson: And so, there's flexibility between the entity who accepts the road and the State of Louisiana-
- Blunck: Correct.
- Jackson: For how this is gonna go forward. And then, if we adopt this resolution, we're not gonna come accept the road from y'all tomorrow, next month, or two months from now.
- Blunck: No, sir.
- Jackson: And my understanding from the October 12th email that I received is that the City is actually moving those water lines-
- Blunck: Correct.
- Jackson: to the sidewalk.
- Blunck: Yes.
- Jackson: So, they are in the process of doing all of this. This is a multi-stepped, multi-phased process.
- Blunck: Correct.
- Jackson: And I, I heard you say before we even accept the road, we would still have to-and negotiations can fail right?
- Blunck: Correct.
- Jackson: They can recognized that negotiations
- Blunck: Correct. Haughton failed when they-
- Jackson: And so, this resolution does nothing but start the process-
- Blunck: Correct.
- Jackson: -of participating in the right sizing program.
- Blunck: But it requires that letter from the Caddo Commission or the City to for the State or the State to start that process and get the monies and the perms passed out.
- Jackson: Right. So, if we never start the process, we'll never get anywhere. There will always be-we'll have Ms. Pearson, Ms. Bogan, Pastor Williams down here begging, again, for Caddo Ford to be right sized; and, what I want to impress upon this body is we've heard from a lot of folks who have said that this is a very traveled road. Amazon is on their way to this area and I have supported the Bel Di Gil Water System, where we had to take over. Didn't we have to take that system over? Oh, I'm sorry, didn't we have to upsize their lines? We paid to upsize their lines. We paid to take over, I mean, we paid to repair Greenwood's water systems. We paid to help out the Lakeview water system. We paid to put a stoplight down in southeast Shreveport. The residents in that area, they pay into the Public Works tax, because every time they go spend money at that Walmart, that Shane's, that Louisiana daiquiri, that Cajun daiquiri, whatever it is up there, that Silver Star, whenever they go up and spend money. They're paying into that Public Works tax, but they never see one dime of benefit coming back to them. This resolution starts the process. It doesn't accept the road. It doesn't commit us. Does this commit us to accepting the road?
- Blunck: No.

Work Session Minutes  
January 18, 2022

- Jackson: It starts the process, and what I heard today is we only want to do the least amount of work. Don't give us anything else extra. Don't make us do any more than what we're already doing. If it is too tedious, if it's too tough. Why are we running away from helping citizens? Citizens who deserve services that we say we provide. We're in the roads and streets business, but absolutely nothing obligates us to taking care of the other issues on that street. All of it is up for negotiation. I would ask that we move this forward to Thursday, and we start this process. Thank you, Mr. President.
- Dr. Wilson: Mr. President, I can get back on the board?
- Jackson: I didn't know I was here to debate Administration.
- Dr. Wilson: No, I'm just getting on the-
- Jackson: I mean, but we got your letter. We got your letter.
- Dr. Wilson: I think-I think the board
- Atkins: Let me take-hold on.
- Jackson: Man, I'm just saying.
- Atkins: I've got, I've got the floor. You've spoken. We all listened, and you're back on the board. No, you're not. If you need to. If you need to get back on the board, get back on the board. We have Commissioner Chavez.
- Chavez: Thank you, President. I just had a couple of questions. The gentleman from DOT he said that this doesn't improve the level of service and I missed that. What is? What does that mean, doesn't improve the level of service?
- Blunck: What level of services is A through F classifications that the federal government classifies; and, a level of service A would be free flowing, you have no obstructions. B, it slows down. C on to F, where it's gridlock traffic. So, all roads have a level of service. And a lot of it is determined is dictated by how many cars, how many left turns, right turns, and how many lanes, how wide they are or what have you. So, when we're talking about right sizing, whatever the size of the road is, then that is the size of the road. Where we wouldn't propose to widen it, or are allowed to allow it to be six-lane, even though it's three lanes right now.
- Chavez: What's the current level of service rated A through F on this specific street?
- Blunck: There's some C sections and there are some D sections, and usually that level of service that is reported like that, that means it's during the peak hours. So, it's not consistently throughout the day, but at 5pm it does go down to, not gridlock, but stop and go and slower than the speed limit.
- Chavez: I got Okay, so level of service is like the flow. How do you rate the condition of the street itself? Is it an A through F?
- Blunck: No, no. Well, yes and no, but, really, there's an actual numerical score. It's 100 to zero. And they have this machine that runs every two to four years over all the state highways. And it talks about the roughness it talks about the ruts, cracks, and faults. I believe this one is a 46.
- Chavez: is one Texas streets, 100 Louisiana streets?
- Blunck: No. The Interstate I-49, no I-20 at Texas, at the Texas line that we just built, that's a 99. Texas street, I believe, is that 80 something.
- Chavez: I meant the state of Texas as in the quality of the roads. Are we Louisiana at zero and Texas at 100 or where? How's the flow go?
- Blunck: Depends on what road, you know?
- Chavez: But they said this one is 46. And an acceptable road, where we wouldn't have the citizens down here talking about having to wear their seatbelts in the bumps, would be at what? What is it going to be maybe a 75?
- Blunck: Yeah, I would say, I would say so, but in theory, if we, if whoever, when we-when the City of Shreveport-fixes the water valves, the four or five water valves, moves the water line out and gets the sewage line fixed. And I can go out there and actually confidently put two inches of hot mix on it, I should get it up to about an 85. Now, if a contractor comes out there and we mill and we patch and we spend money on it, we can get it up to about a 99, you know?
- Chavez: That's a great segue to my second question is on Ford Street, and nobody will ever say

Work Session Minutes  
January 18, 2022

that Commissioner Jackson is not a champion for his neighborhood. Let me tell you. He worked hard for the for the people over there. Ford Street is it a City street or is it a State Street?

Blunck: It's a state highway. It's LA 173.

Chavez: So, the responsibility is within the State of Louisiana and not the City of Shreveport to overlay this street. Is that right?

Blunck: That's correct.

Chavez: Okay, but you guys only have enough, I guess, in your budget to overlay one street in this district per year?

Blunck: One road. Yes. Well no. Not the district, in the Parish. There's 7 Parishes that's competed for this.

Chavez: So, right now if we don't do this, Commissioner Jackson deals with the citizens and these complaints for who knows how many more years, because the state can never get to it.

Blunck: Over 15, yes. But like I said, now keep in mind in Caddo Parish, and the City, and everybody else, when we maintain, we maintain to different levels. The instant maintain-if there's a pothole they call us or we discover that pothole, we put cold mix in that pothole. That hole gets fixed. You know, it rides like junk, but it's fixed, you know. And then if we have a stretch of road, that's base failure, then we'll come in and we'll smear some hot mix and we'll do a skin patch on it, and that's fixed. But it's-it rides even worse, you know. And then if you-but we have a pavement preservation project that we only get one a year. But you grind all that, with all the patches and fix the bases, and then you-it's a full contractor-and then that's actually when you get a good road, a ride road. But, you know, there's complaints on road maintenance and road ride. The roads can't afford at least Caddo, we just had to put some money into that about, what? Seven years ago? We put-we did a block there, and that was with the City. The City laid it and we paid the hot mix for it.

Chavez: Chairman, may I ask one last question. I know the Biden Administration with the Infrastructure Bill appropriated billions. Are we still stuck on that one street per year? Or is this Infrastructure Bill going to help you out to solve this issue?

Blunck: No, it's not going to help.

Chavez: Where's where is that billions going to?

Blunck: They're going to special projects. So, in other words, as Mr. Jackson asked that same question. When you-I would love for Ford to be there. I'd love for Hearne to be there. I'd love for Common to be there, but Jimmy Davis bridge is going to take it and the Inner City Connector is going to take it, and, you know, the causeway down in New Orleans is going to take it. There's only that they're not going to give it to pavement preservation.

Hopkins: Okay. My question is has he City of Shreveport passed on rightsizing?

Dr. Ward: I talked to Gary Norman, last week, and they've known about it; and, he said that he couldn't make that decision. He would have to get with Chief White and the Mayor to, you know, to move that forward. Because before that, Patrick Furlong, you know, was involved and now they've kind of moved their hierarchy over there. So, I mean, and right now, the City is engaged with Raley and Associates to do some surveying on the waterline. So, they are trying to move forward. So, that's a long, its a two-year process to get the water lines moved, so.

Blunck: But we can say that as he's saying that the previous City Engineer and the previous City Engineer before that, Mr. Westerman, they all were in-they had different Mayors. This is not a new concept. It's an old concept that, you know, it- you can't-I can't say it's good or bad. I can say that the City of Bossier's enjoying the East Bank, and they took Barksdale over. And they've got, you know, bypass and park benches and all that. And it's probably easier for the City than the Parish to take it over. Because they have more need or infrastructure. But you know, your Mayor, your Mayor's got to be on board with it.

Hopkins: And I guess, Mr. Jackson's, right, we try. We try to work together as much as we can. There are some things that give me great concern from being a one-time Parish employee in Public Works. And I know for sure we do not have the expertise on traffic signals. We don't have the equipment. We don't have the manpower. So, we would have-we would be-the City of Shreveport would have to still do that, but it wouldn't be that, well but it's a road. In the sense, that it's inside the City? The City does is traffic engineering, correct?

Blunck: So, as far as right now, the City and the City State that has a City State Agreement that we pay for the traffic signals that are maintained, but they maintain them with their traffic engineering.

Work Session Minutes  
January 18, 2022

- Hopkins: So, you would pay us, but like, I guess the other thing is we don't have-
- Blunck: We would adopt the traffic signals that are not-would not-be in the State Highway. So, in other words, Common, Market Spring, and Hearne all are still going to be in a State Highway System. So, we're still paying the City. But then I think it's Highland, is it? There's two or three, maybe four more that you would adopt, yes. And so you either would have to enter in with a City State Agreement, or take them down for all we-it's not our road anymore.
- Hopkins: Because there is-I'm looking at this and I'm seeing the complexity of it. Because you've got a state road that's inside the City, which makes the traffic regulations inside the City, has speed limits and stuff like that. So, we don't have the authority to do that inside that municipality. So, there's still some problems, I see; and, the main thing is the bridge. We're at the end of the life of that bridge, basically. I mean, we're-they say 10 years way? That could be very, off by two or three years, and that we need to do something immediately. And that's, that's a big bridge. I know which bridge it is and so that gives me concern. That's all I have.
- Blunck: Can I say anything about the bridge or no? The bridge right now is in a good rating; and, I'm not saying-and I do know, well, I do know that our state, our state system, once again, with the overlay, you're not gonna like to hear that-we're replacing a bridge every 200 years, you know. So, if this bridge, if 173 were to go to, if it were to go into a condition of we have to close it down, we're going to have to close it down because we can't replace it.
- Hopkins: you mean like 530 and Caddo Lake Bridge?
- Blunck: Yeah, absolutely. 530 is a great example, that it never well, LA-1, we just had to close it down. And it wasn't because we were-Yes, we were replacing it-but we, it went down so bad that we had to close it down whether it was just lucky that we were replacing it. You know that because that's your district, you know; and so, I know this is bleak for the state, but that is the alternative if the Parish did take it, and the bridge went to, you know, went to zero, or went to a rating of whatever, you're probably in the same boat that we would be in.
- Hopkins: We wouldn't be responsible if you still had it.
- Blunck: Right. But you still, whoever the user is would not. They're still looking at they don't have a bridge.
- Dr. Wilson: If neither city, neither city or the Parish, accept this road, when would you all get around to doing that? Your own road?
- Blunck: Like, like I said, it depends on what you're wanting to talk about doing. If we're talking about the repair of water lines that are leaking on the roadway, then once the City repairs their water lines there they have promised that they're going to move them outside of out from underneath the roadway. When that happens, then we-I pledged in promises like that-that we would go in overlay two blocks of it. As for to put it in the pavement, and that would be with our forces, with as for when we will have it in the pavement preservation, right now we're looking at probably 15 to 16 more years.
- Dr. Wilson: Okay. Mr. Blunck I was out there the other day for the third or fourth time looking at it. There are forced sewer mains in the center of the road. What's going to be done about that?
- Blunck: That's the city.
- Dr. Wilson: So, in other words, no matter who owns the surface of the road, the City will have to dig it up occasionally to make repairs on it.
- Blunck: That's correct. Just like your Parish roads. I assume that they do that same thing to your Parish roads.
- Dr. Wilson: No, we don't. We don't have forced mains that our parents roads, we have culverts that we take care of, but not force main utility systems like that.
- Blunck: So you're saying that there is no sewerage lines that are cross, that are going down or any entire Parish roads?
- Dr. Wilson: We don't have sewer plants outside the parish, in the Parish. We have a sewer treatment plant here in the City. We don't have any in the Parish.
- Blunck: So, that's an unfortunate thing for right sizing. Now, of course, that's something to be discussed. But that's the unfortunate thing with the right sizing that you inherit all utilities that have done things in the, you know, 50 years ago. Electricity, telephone or sewer.
- Taliaferro: Thank you, Mr. President, as I understand it, so this is all conditional on whether the City

Work Session Minutes  
January 18, 2022

does its infrastructure repair or not correct?

Blunck: Which part?

Taliaferro: The overlaying, the repairing of the roadway, what we're talking about here. ,So in other words, no, it's not.

Blunck: No. What I understand the resolution is he's asking the y'all make a letter and send it to the Secretary of Department Transportation for them to work up a package for you to receive and look over and start a negotiation for right sizing. The City they have to repair their waterline and they have-well, I see they have to, you know. Apparently, they can allow it to leak for, you know, years and-

Taliaferro: Which is a moot point then for us to even getting in the engagement into any kind of research or any kind of proposal or anything like that unless we have a great infrastructure underneath. I mean, I don't disagree Fort Street. I and I've traveled it many, many, many times over my career as a law enforcement officer and it is always been in poor, poor shape. We all know that it does need to be repaired. I'm just not convinced or I'm very concerned that even going through the negotiation process or the research process that unless the City's ponies up and does what they're supposed to do by fixing the infrastructure underneath, which is in poor condition, probably. Then, you know, it just seems like it's a moot point. If I was going to do anything, I would, you know, send it to a committee based on the City doing their deal and fixing the infrastructure repairs underneath. Thank you, Mr. President.

Young: Thank you, Mr. President. I wanted to ask a quick question about the bridge, Mr. Blunck. Did you indicate to us that when the bridge falls into disrepair, there will be no one to repair it?

Blunck: No, no, I'm not indicating that. No, I'm not saying that. We continue to repair bridges. However, this bridge right now is in good. It has no weight rating, and then it'll start dropping down. And then, it'll start low grading the bridge and then we'll have to repair it to try to bring it back up to standards. And, it'll have a slow decline and it'll go back down to 2015. And then, as he was talking about was, at the end of end of its life, it will be at a 510 ton no trucks whatsoever are allowed. But that's, that's not 50 years, that's probably going to be, if I were to guess, 100 years.

Young: 100 years from now.

Blunck: Well, 100 years from '87.

Young: Okay, so, for the foreseeable future, we'll have a bridge that crosses the shore.

Blunck: And it'll be in a good, good condition, good shape bridge that that had that's able to take any load that we need.

Young: Okay, thank you. And so, just a quick follow up question. Have you Did you read the letter that Dr. Wilson wrote us about this topic? Okay, well, let me ask you about some of my highlights from it. So, the first one is the 55 lights, the traffic signals, the sewer and the water, and the hydrants on the sidewalks those are going to those are still City properties. Is that correct?

Blunck: Sewer, water, sidewalks-

Young: The streetlights.

Blunck: -and streetlights are also.

Young: So, unless we made some different agreement with the City, we wouldn't be taking care of those? We would just be

Blunck: You would serve them to take care of them.

Young: The City would take care of those.

Blunck: And you would expect them-if something happened-then, it would be your responsibility to contact the City and say 'hey, take care of your stuff'.

Young: Okay. And then. So, this letter also said that the entire road needs to be taken in, but that's-but that's not accurate. Is that your opinion? It's-you wanted your department to go from one state highway intersection to another-

Blunck: Correct.

Young: along this road. So, it could be any of several segments?

Work Session Minutes  
January 18, 2022

Blunck: Correct.

Atkins: Thank you, Mr. President. Commissioner Jackson, as I understand your resolution, this is to get the process going correctly. So, if I understand the resolution as it is, I think it'd be best for us to start the process in a lot of these questions that we have. We still can ask these questions. We still can do the research, but we've got to get the ball rolling somewhere. I don't see how-because some of the stuff that we're asking-you mentioned about the bridge. I would have to be 102 years old before that bridge is deemed to be repaired. So, I don't think any of us are going to live to the point to where we're going to have to worry about that bridge being repaired so much today, that we can't even get this resolution moving forward. So, I'm thinking that if we're going to try to make some improvements, and be of service to our constituents, we've got to at least do the due diligence of starting the process. And, it seems like we're not even trying to do that. Am I misunderstanding something?

Dr. Wilson: Commissioner Jones I'm assuming if you start a process that has the beginning and an end, right?

Jones: Absolutely.

Dr. Wilson: And, I'm telling you if you go forward with the process, the ultimate goal seem to be to right size and what would be end up accepting it. I'm telling you, there's something we ought to consider and while we go through it, and I'm trying to give you enough information you can make an informed decision; but, you want to go forward with something that you have to maintain eventually. And I'm telling you there's limits in our ability to maintain that road.

Dr. Wilson: I'm pointing out to you as informed commissioner voter that it's not like a Parish road that we take here all the time. These-this road require some additional skill set and equipment that we currently don't utilize to maintain that road, because we will have the storm drain system on our road too as part of inheriting the road. And, it is not easy to clean those systems out. We'd have to buy additional back big fat trucks to suck those things out. All that stuff that we're having purchased. We don't have any of that.

Jones: Okay, I guess the resolution is to start the process to get a package back, so we can understand what we're dealing with right?

Dr. Wilson: Yes, sir.

Jones: Okay. So, why not? And we still have to accept the right size. We can be considered, but we will still have to make a decision down the road to accept this correct. Am I right?

Blunck: Yes, sir. You would have to, they would have to negotiate and get everything in writing. All the monies. And, then, you would have to either decide how you want to spend the \$2.8 million or push it back into credits. The project that we're talking about to bring the road up from poor to fair, that is right now to good to very good, would have to go at least have to go in place. Unless you're going to do it like Bossier City and then you take all of the money and then you could spend the money the way-

Jones: On the road.

Blunck: -the way you want it and you can put park benches and whatever you want in it. But, that's all before. I'm just spitballing the 2.8 out, because that's what Baton Rouge has already said. That money that's not a that's a negotiable number and the scope is a negotiable scope. And, that's one thing that y'all are going to need to decide, and maybe not tonight or whatever. But I do know that whenever it was the Pierre and to Hartman is not going to be acceptable. So, you're going to need to know whether or not it's going to be Common to Hearne, whether or not it's going to be Spring to Hearne, whether or not it's going to be to 220, or whether or not. Common to Hearne's your smallest piece that we would be interested in. Market to Hearne. It sounds like the big one because y'all are wanting Pierre to Heartman, which is that two to four block in front of the Head Start that's hot mix. But unfortunately, we can't have dangling road in there, you know. So if we're going to split it, we're gonna have to split it to a no.

Blunck: And, by the way, the 100 years I'm just giving you a idea of how bridge replacements work. We keep on maintaining them and we keep fighting the good fight. So, it may not last 100 years, and it would absolutely probably start, absolutely probably, start requiring maintenance money about 50 years into it. At about 2037 You're probably gonna need to start spending some money on maintaining it. Now of course, in our Right Sizing Program, which is also negotiable, but it says that they're allocating \$400,000 of the of the 2.8 for the 40 years of maintenance.

Jackson: Thank you, Mr. President. Let me just say again, that as of today, the bridge is not an issue. On the Tim James row when it is completed, if it is ever completed the maintenance and upkeep of that bridge and that road is not going to be an issue. It's not an issue. We are jumping to the worst possible outcome. And what is before us is a process. It starts a

process and to say, we don't even want to start the process, is unimaginable today. We have staff that is paid every day to come in and talk about and discuss how we're going to provide roads and bridge services to the citizens of Caddo Parish. School Park is in Caddo Parish, folks. Allendale is in Caddo Parish. Squirrel Point, where Chief Whitehorn cuts through every morning to come to work, is in Caddo Parish. This is a process. I heard Dr. Wilson say, we don't have the equipment. We don't have to have the equipment tomorrow, do we?

Blunck: We don't have equipment either.

Jackson: Okay, is their road and they don't have the equipment. But guess what else we didn't have equipment for? We didn't have equipment for that snow that hit the roads last-early last year. But what did we come down here and do? We bought the equipment. This is what we do. And to sit here and say, we're not gonna even start a process? I just think that it is unimaginable for the people we say we represent and the resources they pay a lot of taxes when they go up there to that Walmart, and to that Shane's, and to those other locations that are in the Parish to shop. I'm there, probably just because of my spending habits, but I'm up in that area almost every other day. I eat out almost every day. So, why shouldn't the residents in these areas benefit? But we're gonna spend our Public Works dollars on the road to connect the Red River expressway. This is an issue of equity. This is an issue of equitable resources. We start talking about how we distribute resources around the Parish you telling people who pay into a public works tax, they cannot benefit from it. They cannot reap the services of it. And oh, by the way, we're not going to even consider a process that may or may not result in that. I just don't understand. Buncombe Road starts out in the City of Shreveport, converts to a Parish road about midway, and before you finish to get back out to the Pines Road, you back on the City street. And they have residential utilities on it. They've got sewer on it. In there, from time to time, just potholes on it. And so, there are scenarios off Dixie Garden. When you come into Dixie Garden off of, what is that? Captain Shreve? You come in off of Captain Shreve, you go down Dixie Road and you come back onto a State Road, 70th Street. So, these scenarios are there all the time. There're utilities on Dixie Road. There're homes on Dixie Road. There're sidewalks on Dixie Road. There are gutters on Dixie Road. So, our action to do today and Thursday is start the process and let's see where we end up. Thank you, Mr. President.

At this time, Mr. Jackson's motion carried, as shown by the following roll call votes: AYES: Commissioners Chavez, Gage-Watts, Jackson, Johnson, Jones, Taliaferro, and Young (7). NAYS: Commissioners Atkins, Hopkins, and Lazarus (3). ABSENT: Commissioners Burrell and Epperson (2). ABSTAIN: None (0).

It was **moved by Mr. Jackson**, seconded by Mr. Jones, *to advance Grace Project as a Visitor for January 20, 2022 Regular Session. Motion carried*, as shown by the following roll call votes: AYES: Commissioners Atkins, Chavez, Gage-Watts, Hopkins, Jackson, Johnson, Jones, Lazarus, Taliaferro, and Young (10). NAYS: None (0). ABSENT: Commissioners Burrell and Epperson (2). ABSTAIN: None (0).

### **COMMUNIQUES AND COMMITTEE REPORTS**

- Mr. Johnson wanted to know if the equipment was bought for the wintry mix that this area is supposed to receive. Dr. Ward said that the funds were approved for the budget, and the order has been submitted for the materials.

### **CONSENT AGENDA**

- *Ordinance No. 6155 of 2022, an ordinance amending the Budget of Estimated Revenues & Expenditures for the Economic Development Fund in the amount of \$5,000 to provide an additional appropriation for the Delta Upsilon Lambda Foundation, and to otherwise provide with respect thereto*
- *Ordinance No. 6156 of 2022, an ordinance amending the Budget of Estimated Revenues & Expenditures for the Economic Development Fund in the amount of \$5,000 to provide an additional appropriation for the Dress for Success Shreveport-Bossier, and to otherwise provide with respect thereto*
- *Ordinance No. 6157 of 2022, an ordinance amending the Budget of Estimated Revenues & Expenditures for the Public Works Fund and the Capital Outlay Fund in the amount of \$107,500 to provide an appropriation to install welcome signs on I-49, and to otherwise provide with respect thereto*
- *Ordinance No. 6158 of 2022, an ordinance amending the Budget of Estimated Revenues & Expenditures for the Economic Development Fund in the amount of \$5,000 to provide an appropriation for Friends in Unity, and to otherwise provide with respect thereto*

- *Ordinance No. 6159 of 2022, an ordinance amending the Budget of Estimated Revenues & Expenditures for the Economic Development Fund in the amount of \$10,000 to reduce the appropriation for the Playaz & Playettes, Inc., and to otherwise provide with respect thereto*
- *Ordinance No. 6160 of 2022, an ordinance amending the Budget of Estimated Revenues & Expenditures for the Oil & Gas Fund for the year 2022 to provide an appropriation of \$109,000 to provide Caddo Fire District No. 7 with a part-time employee, and to otherwise provide with respect thereto*
- *Ordinance No. 6161 of 2022, an ordinance amending the Budget of Estimated Revenues for the American Rescue Plan Fund to provide an appropriation of up to \$30,000 for Red G Enterprises, and to otherwise provide with respect thereto*
- *Ordinance No. 6162 of 2022, an ordinance amending the Budget of Estimated Revenues for the American Rescue Plan Fund to provide an appropriation for counseling in public high schools in Caddo Parish and to otherwise provide with respect thereto*
- *Ordinance No. 6163 of 2022, an ordinance amending the Budget of Estimated Revenues for the American Rescue Plan Fund to provide an appropriation for Volunteers for Youth Justice for truancy, and to otherwise provide with respect thereto*
- *Ordinance No. 6164 of 2022, an ordinance amending the Budget of Estimated Revenues for the American Rescue Plan Fund to provide an appropriation for Caddo Parish Juvenile Court, and to otherwise provide with respect thereto*
- *Ordinance No. 6165 of 2022, an ordinance amending the Budget of Estimated Revenues & Expenditures for the E. Edward Jones Housing Trust Fund to provide an appropriation for ERAP Housing Quality Inspections and to otherwise provide with respect thereto*
- *Ordinance No. 6166 of 2022, an ordinance amending the Budget of Estimated Revenues & Expenditures for the E. Edward Jones Housing Trust Fund to roll over an existing 2021 appropriation for eviction mitigation into the 2022 Budget, and to otherwise provide with respect thereto*
- *Ordinance No. 6169 of 2022, an ordinance approving a cooperative endeavor agreement with Tim James, Inc. relative to construction of a privately-owned tollway over the Red River pursuant to Louisiana Revised Statute 48:2037, and to otherwise providing with respect thereto*
- *Ordinance No. 6170 of 2022, an ordinance amending the Budget of Estimated Revenues & Expenditures for the Oil & Gas Fund for the year 2022 to provide an appropriation for relocation assistance, and to otherwise provide with respect thereto*
- *Ordinance No. 6171 of 2022, an ordinance amending the 2022 Budget of Estimated Revenues & Expenditures for the American Rescue Plan Fund to provide an additional appropriation for Fit For Life Ministries, and to otherwise provide with respect thereto*
- *Ordinance No. 6172 of 2022, an ordinance amending the 2022 Budget of Estimated Revenues & Expenditures for the E. Edward Jones Housing Trust Fund to provide appropriations for housing projects, and to otherwise provide with respect thereto*
- *Resolution No. 84 of 2021, urge and request the Louisiana Department of Natural Resources to consider negative impacts of oil and gas drilling in or near urban areas, implement rules to combat those negative impacts, and to otherwise provide with respect thereto*
- *Appoint members to the Caddo Parish Planning Commission. Commission to appoint 5. Kay Proby-Waller to fill one spot.*

At this time, there was no further discussion to come before the Commission, so the Commission adjourned at 6:43 p.m.

  
Assistant Commission Clerk

## **RESOLUTION No. 20 of 2022**

### **BY THE CADDO PARISH COMMISSION**

A RESOLUTION CONFIRMING PARTICIPATION IN THE LOUISIANA COMMUNITY DEVELOPMENT BLOCK GRANT FISCAL YEAR 2022 PUBLIC FACILITY IMPROVEMENT PROJECT WITH WATERWORKS DISTRICT NO. 7, IDENTIFYING PARTNERS AND OTHERWISE PROVIDING WITH RESPECT THERETO

WHEREAS, the Caddo Parish Commission is submitting an application for a FY 2022 Louisiana Community Development Block Grant (LCDBG) for public facility improvements; and

WHEREAS, the Caddo Parish Commission has entered into contracts with The Coordinating & Development Corporation for administrative services and CGS Engineering, Inc. for engineering services, and agree all administrative services/engineering costs will be paid by the Caddo Parish Commission and Waterworks District No. 7; and

WHEREAS, the Board of Directors of Waterworks District No.7 has passed a resolution stating that if grant funds are made available for the public facility improvement project, the Board will contribute 10% of the total project funds up to \$100,000 to construction and design of the project (engineering fees); and

WHEREAS, the Caddo Parish Commission will pay The Coordinating & Development Corporation an amount of \$36,400 for LCDBG pre-agreement and administrative services. CGS Engineering, Inc. proposed contract amount is \$116,000. The Board of Directors of Waterworks District No. 7 will contribute \$100,000, and the Caddo Commission will pay the remaining \$16,000 for the engineering services; and

WHEREAS, the Caddo Parish Commission will receive 2 bonus points for their monetary contributions for paying engineering costs.

NOW THEREFORE BE IT RESOLVED, the Commission President and Parish Commission of Caddo Parish, Louisiana, do hereby agree to pay for the aforementioned engineering and administration fees associated with the implementation of the LCDBG programs out of local funds.

### **C E R T I F I C A T E**

I, Jeff Everson, Commission Clerk, hereby certify that the above constitutes a true and accurate copy of a Resolution, which UPON MOTION of

, and seconded by , was  
adopted by the following Yea and Nay vote:

YEA:

NAY:

ABSENT:

and the same was declared adopted by the Commission President this      day of  
, 2022.

---

Jeff Everson, Commission Clerk  
Caddo Parish, Louisiana