

**CADDO PARISH COMMISSION**  
**505 TRAVIS STREET, GOVERNMENT PLAZA**  
**PUBLIC NOTICE**  
**WORK SESSION AGENDA**  
Streaming at [www.caddo.org](http://www.caddo.org)  
February 14, 2022  
**3:30 P.M.**

1. ROLL CALL:

**Commissioners:**

Hopkins	District 1	Gage-Watts	District 7
Johnson	District 2	Taliaferro	District 8
Jackson	District 3	Atkins	District 9
Young	District 4	Chavez	District 10
Burrell	District 5	Lazarus	District 11
Jones	District 6	Epperson	District 12

2. INVOCATION:

3. PLEDGE OF ALLEGIANCE:

Veterans and active military members saluting during recitation of the Pledge of Allegiance would be appropriate, should you wish to do so.

4. AGENDA ADDITIONS:

5. CITIZENS COMMENTS:

Citizens who wish to address the Commission on any issue other than zoning, please fill out a comment card located in the chamber foyer and return to the President or the Clerk of the Commission. Individual comments are limited to 3 minutes

6. VISITORS:

7. COMMISSION REMARKS:

Communiques, reports, and other items related to Work Session Agenda.

7.I. REPORTS:

Administrator Report

7.I.i. Administration Report

Documents:

[ADMINISTRATION REPORT 02.14.22.PDF](#)

7.II. PRESIDENT'S REPORT:

8. OLD BUSINESS:

9. NEW BUSINESS:

9.I. Authorize Introduction Of Ordinance No. 6194 Of 2022

AN ORDINANCE TO ACCEPT THE STREETS IN OLD TOWNE SUBDIVISION UNIT 1 INTO THE PARISH OF CADDO ROAD SYSTEM, AND TO OTHERWISE PROVIDE WITH RESPECT THERETO

(District 1)

Documents:

[ORD NO 6194 OLD TOWNE SUBDIVISION UNIT 1 STREETS ACCEPT  
ORD.DOC](#)  
[ORD NO 6194 FACT SHEET FOR OLD TOWNE SUBDIVISION UNIT 1  
ORDINANCE \(1\).DOC](#)  
[ORD NO 6194- EXHIBIT A OLD TOWNE UNIT 1.PDF](#)

9.II. Authorize Introduction Of Ordinance No. 6195 Of 2022

AN ORDINANCE TO ACCEPT THE STREETS IN BLANCHARD LAKE ESTATES UNIT 4 INTO THE PARISH OF CADDO ROAD SYSTEM, AND TO OTHERWISE PROVIDE WITH RESPECT THERETO

(District 1)

Documents:

[ORD NO 6195 - BLANCHARD LAKE ESTATES UNIT 4 STREETS ACCEPT  
ORD \(1\).PDF](#)  
[ORD NO 6195 FACT SHEET FOR BLANCHARD LAKE ESTATES UNIT 4  
ORDINANCE.PDF](#)  
[ORD NO 6195- EXHIBIT A BLANCHARD LAKE ESTATE UNIT 4 \(1\).PDF](#)

9.III. Authorize Introduction Of Ordinance No. 6196 Of 2022

AN ORDINANCE AMENDING THE BUDGET OF ESTIMATED REVENUES FOR THE AMERICAN RESCUE PLAN FUND TO PROVIDE AN APPROPRIATION FOR JUVENILE CENTER IN CADDO PARISH AND TO OTHERWISE PROVIDE WITH RESPECT THERETO

(American Rescue Plan Committee)

Documents:

[ORD NO 6196- JUVENILE CENTER.PDF](#)  
[ORD NO 6196 FACT SHEET - JUVENILE ONE STOP CENTER.PDF](#)

9.IV. Authorize Introduction Of Ordinance No. 6197 Of 2022

AN ORDINANCE AMENDING THE BUDGET OF ESTIMATED REVENUES AND EXPENDITURES FOR THE RIVERBOAT FUND TO APPROPRIATE FUNDS FOR THE CADDO PARKS GRAB AND GO FEEDING PROGRAM AND TO OTHERWISE PROVIDE WITH RESPECT THERETO

(Appropriations Committee)

Documents:

[ORD NO 6197- GRAB AND GO FEEDING PROGRAM.PDF](#)  
[ORD NO 6197 GRAB AND GO FACT SHEET.PDF](#)  
[ORD NO 6197 GRAB AND GO EXHIBIT 1.PDF](#)

9.V. Authorize Introduction Of Ordinance No. 6198 Of 2022

AN ORDINANCE AMENDING THE BUDGET OF ESTIMATED REVENUES AND EXPENDITURES FOR THE RIVERBOAT FUND FOR THE YEAR 2022 TO PROVIDE AN ADDITIONAL APPROPRIATION OF \$15,000 FOR ROBINSON'S RESCUE AND TO OTHERWISE PROVIDE WITH RESPECT THERETO

(Appropriations, Animal Services)

Documents:

[ORD NO 6198 ROBINSONS RESCUE.PDF](#)

ORD NO 6198 FACT SHEET - ROBINSON RESCUE.PDF

9.VI. Authorize Introduction Of Ordinance No. 6199 Of 2022

AN ORDINANCE AMENDING THE BUDGET OF ESTIMATED REVENUES AND EXPENDITURES FOR THE RIVERBOAT FUND FOR THE YEAR 2022 TO PROVIDE AN APPROPRIATION TO PROVIDE BALLISTIC VESTS FOR SHREVEPORT AND CADDO PARISH FIRE DISTRICTS, AND TO OTHERWISE PROVIDE WITH RESPECT THERETO

(Taliaferro)

Documents:

[ORD NO 6199 FIRE DISTRICT BALLISTIC VEST.PDF](#)  
[ORD NO 6199 FACT SHEET -FIRE BALLISTIC VEST.PDF](#)

9.VII. Authorize Introduction Of Ordinance No. 6200 Of 2022

AN ORDINANCE TO ESTABLISH A TEMPORARY PARISH PLANNING AND ZONING COMMISSION, TO PROVIDE FOR ITS MEMBERSHIP, TO PROVIDE FOR AN EFFECTIVE DATE, AND TO OTHERWISE PROVIDE WITH RESPECT THERETO

(Johnson and Chavez)

Documents:

[ORD NO. 6200- TEMPORARY PLANNING AND ZONING COMMISSION- JOHNSON AND CHAVEZ-CORRECTED.PDF](#)  
[ORD 6200 FACT SHEET FOR TEMPORARY PLANNING COMMISSION.PDF](#)

9.VIII. Authorize Introduction Of Ordinance No. 6201 Of 2022

AN ORDINANCE AMENDING ORDINANCE 6071 OF 2021 TO ESTABLISH A PARISH PLANNING AND ZONING COMMISSION, TO PROVIDE FOR ITS MEMBERSHIP, TO PROVIDE FOR AN EFFECTIVE DATE, AND TO OTHERWISE PROVIDE WITH RESPECT THERETO

(Burrell)

Documents:

[ORD NO 6201 PLANNING AND ZONING COMMISSION-BURRELL AMENDMENT.PDF](#)  
[ORD 6201- FACT SHEET FOR AT LARGE APPOINTEE FOR PLANNING AND ZONING COMMISSION.PDF](#)

9.IX. Authorize Introduction Of Ordinance No. 6202 Of 2022

AN ORDINANCE TO AUTHORIZE THE ADMINISTRATOR TO EXECUTE AN PREDIAL SERVITUDE OF PASSAGE AND RIGHT TO USE OVER PARISH PROPERTY LOCATED IN SOUTHWESTERN QUARTER OF SECTION 28, TOWNSHIP 22 NORTH RANGE 16 WEST AND TO OTHERWISE PROVIDE WITH

RESPECT THERETO

(Public Works, Legal) (District 1)

Documents:

[ORD NO 6202- PREDIAL SERVITUDE.PDF](#)

[ORD NO. 6202- EXHIBIT A.PDF](#)

[FACT SHEET FOR ORD NO 6202 - BLAKEMAN RIGHT OF PASSAGE.PDF](#)

9.X. Authorize Introduction Of Ordinance No. 6203 Of 2022

AN ORDINANCE TO AUTHORIZE THE ADMINISTRATOR TO EXECUTE AN EASEMENT AND RIGHT-OF-WAY AGREEMENT WITH CADDEAUX GATHERING, LLC REGARDING A PIPELINE THROUGH AND UNDER PARISH PROPERTY LOCATED IN SECTION 7, TOWNSHIP 18 NORTH, RANGE 15 WEST, CADDO PARISH, LOUISIANA, AND TO OTHERWISE PROVIDE WITH RESPECT THERETO

(Public Works, Legal) (District 1)

Documents:

[ORDINANCE 6203- CADDEAUX.PDF](#)

[ORDINANCE 6203 EXHIBIT A.PDF](#)

[FACT SHEET FOR ORD NO 6203 CADDEAUX GATHERING.PDF](#)

9.XI. Authorize Resolution No. 19 Of 2022

A RESOLUTION AMENDING THE RULES AND BY-LAWS OF THE CADDO PARISH COMMISSION REGARDING THE RE-SUBMISSION OF AGENDA ITEMS BY COMMISSIONERS, AND OTHERWISE PROVIDING WITH RESPECT THERETO.

(Chavez)

Documents:

[RES NO 19 OF 2022- AMEND BYLAWS RE RESOLUTION RESUBMISSION 2022-CHAVEZ.PDF](#)

[RES 19 OD 2022- AMEND BYLAWS RE RESOLUTION RESUBMISSION 2022-CHAVEZ.PDF](#)

9.XII. Authorize Resolution No. 20 Of 2022

A RESOLUTION CONFIRMING PARTICIPATION IN THE LOUISIANA COMMUNITY DEVELOPMENT BLOCK GRANT FISCAL YEAR 2022 PUBLIC FACILITY IMPROVEMENT PROJECT WITH WATERWORKS DISTRICT NO. 7, IDENTIFYING PARTNERS AND OTHERWISE PROVIDING WITH RESPECT THERETO

(Finance)

Documents:

[RES NO 20 OF 2022- LADBG WATERWORKS NO 7 AE \(002\).PDF](#)

9.XIII. Authorize Special Resolution Of Remembrance For Bobbie Cates Hicks  
(Atkins)

9.XIV. Authorize Special Resolution Of Recognition & Appreciation For Chris Thomas  
(Chavez)

9.XV. Authorize Appointment To The Caddo Parish Broadband Committee  
Hon. Jame Sims (Hopkins)

10. COMMUNIQUE AND COMMITTEE REPORTS:

11. CITIZENS COMMENTS (Late Arrivals):

Citizens who wish to address the Commission on any issue other than zoning, please fill out a comment card located in the chamber foyer and return to the President or the Clerk of the Commission. Individual comments are limited to 3 minutes

12. CONSENT AGENDA:

12.I. Ordinance No. 6191 Of 2022

AN ORDINANCE AMENDING THE BUDGET OF ESTIMATED REVENUES AND EXPENDITURES FOR THE RIVERBOAT FUND AND OIL AND GAS FUND IN THE AMOUNT OF \$10,000 TO PROVIDE AN APPROPRIATION FOR THE LOUISIANA ADVOCATES FOR IMMIGRANTS IN DETENTION ASSOCIATED WITH THE HIGHLAND CENTER AND TO OTHERWISE PROVIDE WITH RESPECT THERETO

(Young)

Documents:

[ORD NO. 6191- LA AID HIGHLAND.PDF](#)  
[ORD NO. 6191 FACT SHEET - LA AID HIGHLAND.PDF](#)  
[ORD NO. 6191 EXHIBIT- NGO APPLICATION FOR LA-AID.PDF](#)  
[ORD NO. 6191 EXHIBIT- APPLICATION COPY NOT SIGNED.PDF](#)

12.II. Ordinance No. 6193 Of 2022

AN ORDINANCE CREATING THE I-49 NORTH CORRIDOR ECONOMIC DEVELOPMENT DISTRICT, STATE OF LOUISIANA;" DEFINING THE BOUNDARIES THEREOF FROM WHICH AREA LOCAL SALES TAX, PROPERTY TAX AND HOTEL OCCUPANCY TAX INCREMENTS WILL BE DETERMINED AND USED TO FINANCE ECONOMIC DEVELOPMENT PROJECTS IN ACCORDANCE WITH AND AS AUTHORIZED BY PART II OF CHAPTER 27 OF TITLE 33 OF THE LOUISIANA REVISED STATUTES OF 1950, AS AMENDED; AND PROVIDING FOR OTHER MATTERS IN CONNECTION WITH THE FOREGOING.

(Hopkins)

Documents:

13. ADJOURN:

To all persons desiring to attend and observe a meeting of the Caddo Parish Commission, or who wish to present information to the body: If you have physical limitations that require special accommodations in order for you to attend and participate in a meeting of the Caddo Parish Commission, please contact the office of the Caddo Parish Commission Clerk at (318) 226-6596, at least 24 hours in advance of the meeting so that an effort can be made to provide those accommodations.

INTER-OFFICE CORRESPONDENCE

PARISH OF CADDO

ADMINISTRATION REPORT

DATE: FEBRUARY 14, 2022  
TO: CADDO PARISH COMMISSION  
FROM: ADMINISTRATION

---

INFORMATION

- 1.) Monument Relocation Update
- 2.) U.S. Treasury Emergency Rental Assistance Program
- 3.) Juvenile Detention
- 4.) Covid-19 Infection Data
- 5.) Facebook Update

ORDINANCE NO. 6194 of 2022

BY THE CADDO PARISH COMMISSION

**AN ORDINANCE TO ACCEPT THE STREETS IN OLD TOWNE SUBDIVISION UNIT 1 INTO THE PARISH OF CADDO ROAD SYSTEM, AND TO OTHERWISE PROVIDE WITH RESPECT THERETO**

WHEREAS, the Parish of Caddo has received a request to accept the streets in Old Towne Subdivision Unit 1, into the Parish of Caddo road system;

WHEREAS, the Parish of Caddo has received and reviewed the subdivision plats showing a dedication to the Parish of Caddo; and

WHEREAS, the Parish of Caddo finds that the acceptance of the subdivisions into the Parish of Caddo system is in the best interest of the Parish of Caddo.

NOW, THEREFORE BE IT ORDAINED by the Caddo Parish Commission, in due, legal and regular session convened, that the Parish of Caddo hereby accepts into the Parish of Caddo road system all of the streets in Old Towne Subdivision Unit 1, Caddo Parish, Louisiana as shown on the attached subdivision plat marked as "Exhibit A".

BE IT FURTHER ORDAINED that a copy of this ordinance, with a subdivision plat of the Old Towne Subdivision Unit 1 attached thereto as "Exhibit A", shall be filed in the conveyance records of the Parish of Caddo.

BE IT FURTHER ORDAINED that if any provision or item of this ordinance or application thereof is held invalid, such invalidity shall not affect other provisions, items, or applications which can be given effect without the invalid provision, items or applications, and to this end, the provisions of this ordinance are hereby declared severable.

BE IT FURTHER ORDAINED that this ordinance shall be effective ten days after publication in the official journal.

BE IT FURTHER ORDAINED, that all ordinances or parts thereof in conflict herewith are hereby repealed.

Approved as to legal form:

\_\_\_\_\_  
Parish Attorney's Office

\_\_\_\_\_  
Date



# OLD TOWNE SUBDIVISION UNIT I (SHEET 1 OF 2)

A SUBDIVISION OF 26.76 ACRES IN SECTION 3, TOWNSHIP 18 NORTH, RANGE 15 WEST  
CADDO PARISH, LA.

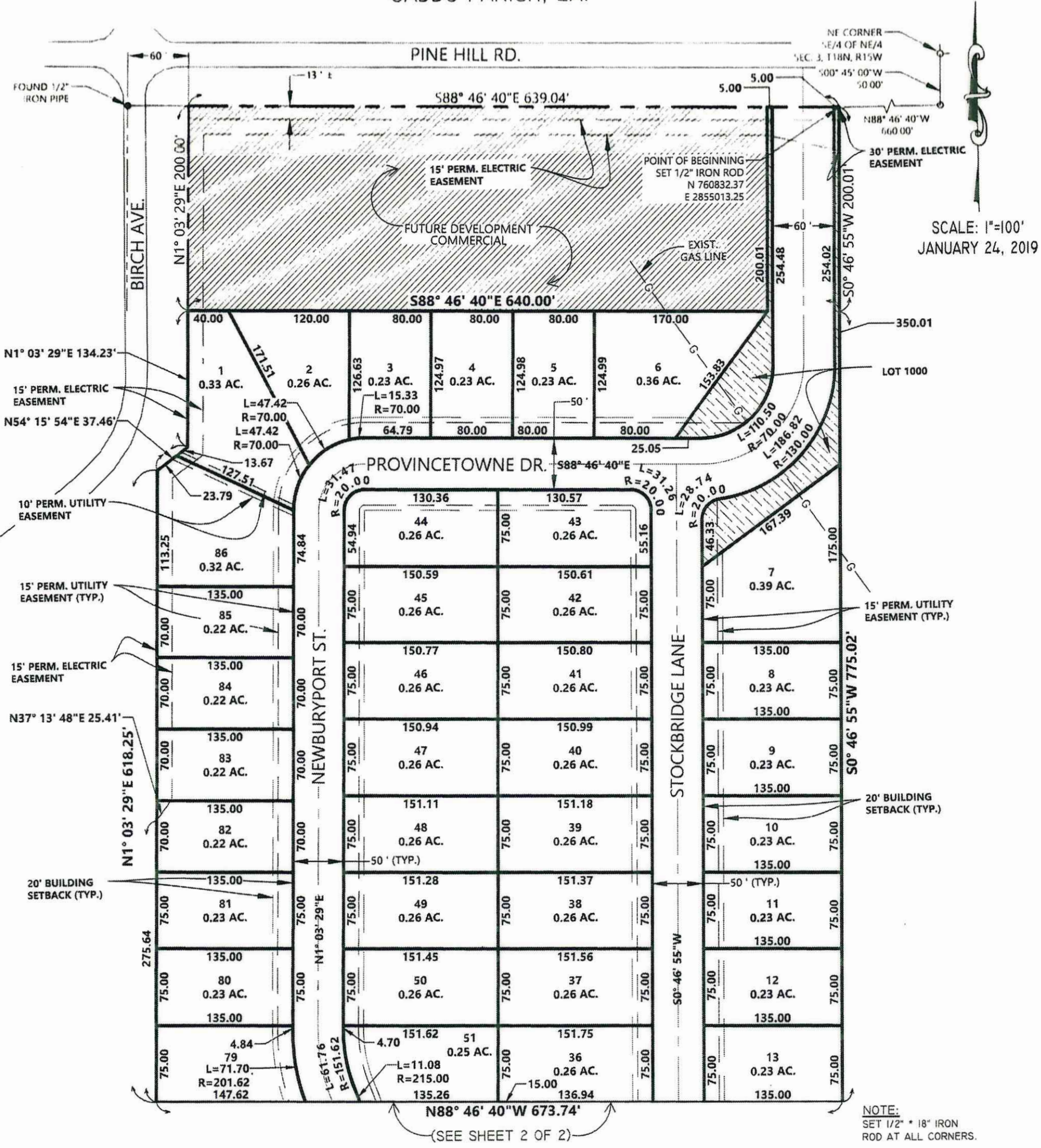

**DEDICATION:** THE UNDERSIGNED OWNER HEREBY DEDICATES TO THE PUBLIC FOR PUBLIC USE THE STREETS AS SHOWN. THE UNDERSIGNED OWNER HEREBY GRANTS UNTO THE TOWN OF BLANCHARD, AEP SWPCO, BELL SOUTH TELEPHONE COMPANY, ARKLA GAS, MACCO COMMUNICATIONS AND/OR ANY OTHER UTILITY, PUBLIC OR PRIVATE, THEIR RESPECTIVE SUCCESSORS AND ASSIGNS, EXCLUSIVELY AND IN PERPETUITY AS A COVENANT RUNNING WITH THE LAND THE RIGHT TO GO UPON THE SEVITUDES FOR UTILITIES HEREIN ESTABLISHED TO INSTALL, MAINTAIN, AND REMOVE FACILITIES APPROPRIATE TO THEIR SERVICES: TO HAVE INGRESS AND EGRESS THERETO OVER ADJACENT LOTS AND LAND; AND/OR CUT AND REMOVE TREES OR OTHER OBSTRUCTIONS AS MAY INTERFERE WITH OR ENDANGER LIFE OR THE OPERATION OF SUCH FACILITIES OR THEIR EFFICIENCY; AND FURTHER AGREES TO HOLD HARMLESS THE PARISH OF CADDO FROM DAMAGES DUE TO CHANGES IN THE STREET GRADES. BINDING HEREIN THEIR HEIRS, SUCCESSORS, AND ASSIGNS.

**RECORD OWNERS:**  
E & L DEVELOPMENT, LLC  
*[Signature]* 4-16-19  
KENNETH G. LAWLER DATE  
PRESIDENT  
Mike Spence, Caddo Clerk of Court

**APPROVAL:**  
*[Signature]* 7/18/19  
MAYOR, TOWN OF BLANCHARD DATE

*[Signature]* 7-2-19  
CADDO PARISH DATE  
DIRECTOR OF PUBLIC WORKS

APPROVAL OF THIS PLAT BY THE PARISH OF CADDO DOES NOT CONSTITUTE AN ACCEPTANCE BY THE PARISH OF CADDO, OR THE PUBLIC, OF ANY OR THE PUBLIC, OF ANY STREETS, DRAINAGE OR OTHER RIGHTS OF WAYS AS SHOWN ON THIS PLAT. ALL STREETS AND ALL DRAINAGE SHALL BE IN ACCORDANCE AND COMPLIANCE WITH CHAPTER 22 OF THE CODE OF ORDINANCES OF THE PARISH OF CADDO. IN ACCORDANCE WITH L.A. R.S. 33\*5051c.(1), THE APPROVAL OF THIS PLAT SHALL NOT CONSTITUTE ACCEPTANCE BY THE PUBLIC OF ANY STREET OR OTHER PUBLIC, WAY, PARK OR SPACE. SUCH APPROVAL CAN ONLY BE EFFECTED BY ACTION OF THE CADDO PARISH COMMISSION. BEARINGS ARE BASED UPON PLAT RECORDED IN BOOK 2300, PAGES 126-127, INCLUSIVE. PER FIRM PANEL 22017C 0335H, DATED MAY 19, 2014, THIS SUBDIVISION IS IN ZONE X.

**NOTES:**  
I, HEREBY CERTIFY THAT THIS SUBDIVISION PLAT CONFORMS TO ALL REGULATIONS AND REQUIREMENTS OF THE SUBDIVISION ORDINANCE AND AMENDMENTS THERETO AS ADOPTED BY THE CADDO PARISH COMMISSION EXCEPT AS RELATED TO ROADS AND DRAINAGE; AND, THAT THIS MAP REPRESENTS AN ACTUAL GROUND SURVEY BY ME OR UNDER MY SUPERVISION.



*[Signature]* 04.16.19

2750186 Pages: 1  
07/08/2019 03:33 PM

# OLD TOWNE SUBDIVISION UNIT I (SHEET 2 OF 2)

A SUBDIVISION OF 26.76 ACRES IN SECTION 3, TOWNSHIP 18 NORTH, RANGE 15 WEST  
CADDO PARISH, LA.

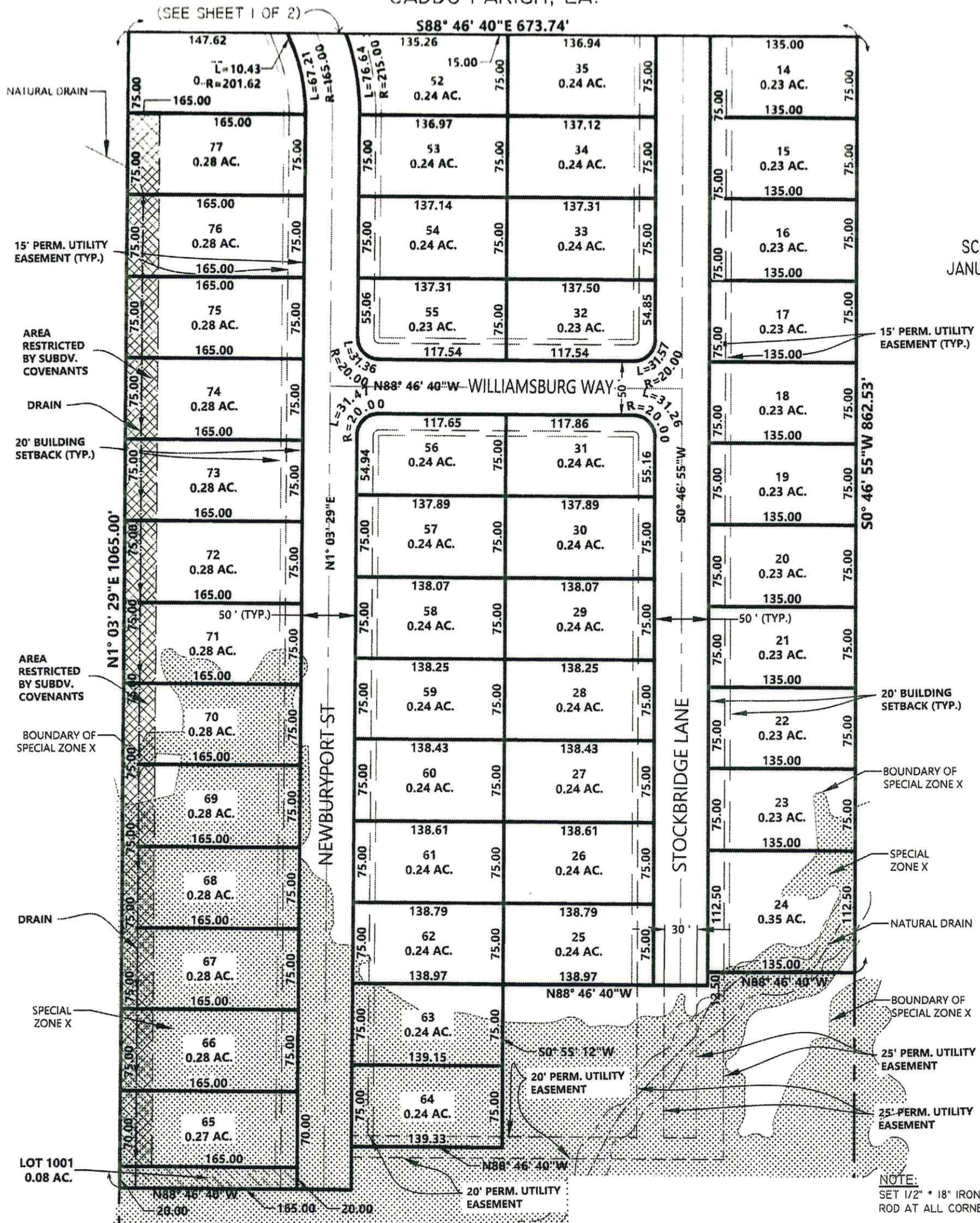

SCALE: 1"=100'  
JANUARY 24, 2019

**DEDICATION:** THE UNDERSIGNED OWNER HEREBY DEDICATES TO THE PUBLIC FOR PUBLIC USE THE STREETS AS SHOWN. THE UNDERSIGNED OWNER HEREBY GRANTS UNTO THE TOWN OF BLANCHARD, AEP SWPCO, BELL SOUTH TELEPHONE COMPANY, ARKLA GAS, MACCO COMMUNICATIONS AND/OR ANY OTHER UTILITY, PUBLIC OR PRIVATE, THEIR RESPECTIVE SUCCESSORS AND ASSIGNS, EXCLUSIVELY AND IN PERPETUITY AS A COVENANT RUNNING WITH THE LAND THE RIGHT TO GO UPON THE SEVITUDES FOR UTILITIES HEREIN ESTABLISHED TO INSTALL, MAINTAIN, AND REMOVE FACILITIES APPROPRIATE TO THEIR SERVICES: TO HAVE INGRESS AND EGRESS THERETO OVER ADJACENT LOTS AND LAND; AND/OR CUT AND REMOVE TREES OR OTHER OBSTRUCTIONS AS MAY INTERFERE WITH OR ENDANGER LIFE OR THE OPERATION OF SUCH FACILITIES OR THEIR EFFICIENCY; AND FURTHER AGREES TO HOLD HARMLESS THE PARISH OF CADDO FROM DAMAGES DUE TO CHANGES IN THE STREET GRADES. BINDING HEREIN THEIR HEIRS, SUCCESSORS, AND ASSIGNS.

**RECORD OWNERS:**  
E & L DEVELOPMENT, LLC

*[Signature]* 4-16-19  
KENNETH G. LAWLER DATE  
PRESIDENT

Mike Spence, Caddo Clerk of Court

**APPROVAL:**  
*[Signature]* 4/18/19  
MAYOR, TOWN OF BLANCHARD DATE

*[Signature]* 7-2-19  
CADDO PARISH DATE  
DIRECTOR OF PUBLIC WORKS

2750186 Pages: 1  
07/08/2019 03:33 PM

APPROVAL OF THIS PLAT BY THE PARISH OF CADDO DOES NOT CONSTITUTE AN ACCEPTANCE BY THE PARISH OF CADDO, OR THE PUBLIC, OF ANY OR THE PUBLIC, OF ANY STREETS, DRAINAGE OR OTHER RIGHTS OF WAYS AS SHOWN ON THIS PLAT. ALL STREETS AND ALL DRAINAGE SHALL BE IN ACCORDANCE AND COMPLIANCE WITH CHAPTER 22 OF THE CODE OF ORDINANCES OF THE PARISH OF CADDO. IN ACCORDANCE WITH L.A. R.S. 33°5051c.(1), THE APPROVAL OF THIS PLAT SHALL NOT CONSTITUTE ACCEPTANCE BY THE PUBLIC OF ANY STREET OR OTHER PUBLIC, WAY, PARK OR SPACE. SUCH APPROVAL CAN ONLY BE EFFECTED BY ACTION OF THE CADDO PARISH COMMISSION. BEARINGS ARE BASED UPON PLAT RECORDED IN BOOK 2300, PAGES 126-127, INCLUSIVE. PER FIRM PANEL 22017C 0335H, DATED MAY 19, 2014, THIS SUBDIVISION IS IN ZONE X.

**NOTES:**

I, HEREBY CERTIFY THAT THIS SUBDIVISION PLAT CONFORMS TO ALL REGULATIONS AND REQUIREMENTS OF THE SUBDIVISION ORDINANCE AND AMENDMENTS THERETO AS ADOPTED BY THE CADDO PARISH COMMISSION EXCEPT AS RELATED TO ROADS AND DRAINAGE; AND, THAT THIS MAP REPRESENTS AN ACTUAL GROUND SURVEY BY ME OR UNDER MY SUPERVISION.



*[Handwritten]* APR 11 2019

ORDINANCE NO. 6195 of 2022

BY THE CADDO PARISH COMMISSION

**AN ORDINANCE TO ACCEPT THE STREETS IN  
BLANCHARD LAKE ESTATES UNIT 4 INTO THE  
PARISH OF CADDO ROAD SYSTEM, AND TO  
OTHERWISE PROVIDE WITH RESPECT THERETO**

WHEREAS, the Parish of Caddo has received a request to accept the streets in Blanchard Lake Estates Unit 4, into the Parish of Caddo road system;

WHEREAS, the Parish of Caddo has received and reviewed the subdivision plats showing a dedication to the Parish of Caddo; and

WHEREAS, the Parish of Caddo finds that the acceptance of the subdivisions into the Parish of Caddo system is in the best interest of the Parish of Caddo.

NOW, THEREFORE BE IT ORDAINED by the Caddo Parish Commission, in due, legal and regular session convened, that the Parish of Caddo hereby accepts into the Parish of Caddo road system all of the streets in Blanchard Lake Estates Unit 4, Caddo Parish, Louisiana as shown on the attached subdivision plat marked as "Exhibit A".

BE IT FURTHER ORDAINED that a copy of this ordinance, with a subdivision plat of the Blanchard Lake Estates Unit 4 attached thereto as "Exhibit A", shall be filed in the conveyance records of the Parish of Caddo.

BE IT FURTHER ORDAINED that if any provision or item of this ordinance or application thereof is held invalid, such invalidity shall not affect other provisions, items, or applications which can be given effect without the invalid provision, items or applications, and to this end, the provisions of this ordinance are hereby declared severable.

BE IT FURTHER ORDAINED that this ordinance shall be effective ten days after publication in the official journal.

BE IT FURTHER ORDAINED, that all ordinances or parts thereof in conflict herewith are hereby repealed.

Approved as to legal form:

\_\_\_\_\_  
Parish Attorney's Office

\_\_\_\_\_  
Date



# BLANCHARD LAKE ESTATES UNIT 4

A SUBDIVISION LOCATED IN SECTION 34, TOWNSHIP 19 NORTH, RANGE 15 WEST, AND SECTION 3, TOWNSHIP 18 NORTH, RANGE 15 WEST IN CADDO PARISH, LOUISIANA CONTAINING 8.805 ACRES.

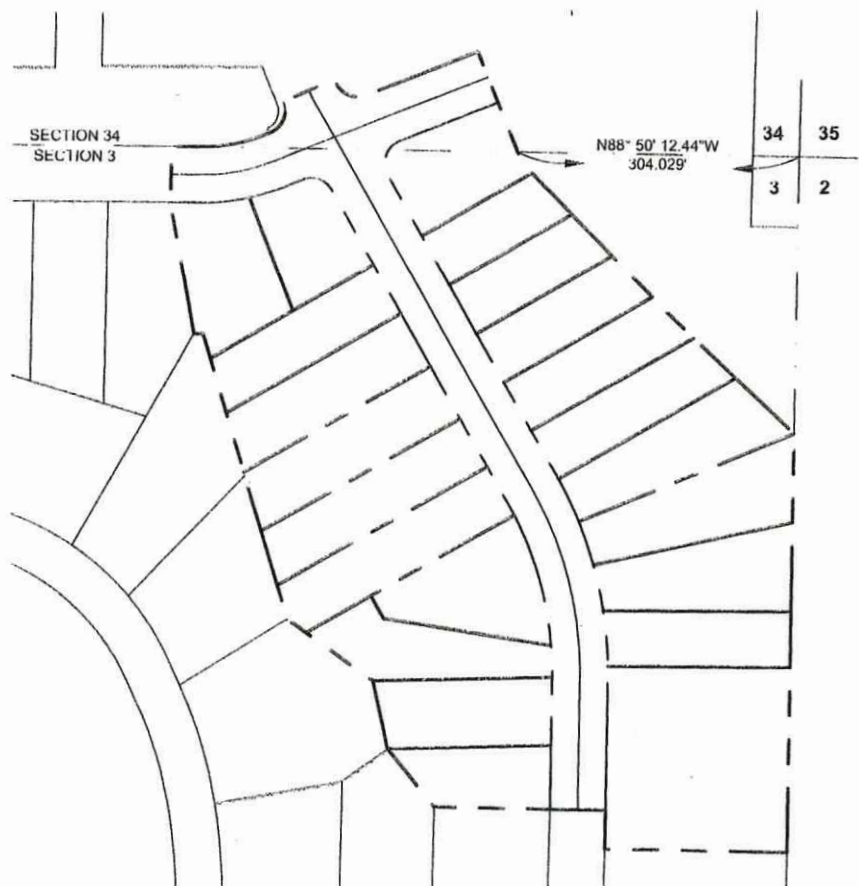

0' 100' 200' 400'  
 SCALE: 1"=200'  
 DATE: JANUARY 2020

Mike Spence, Caddo Clerk of Court



2777064 Pages: 2  
 02/07/2020 10:59 AM

THE UNDERSIGNED OWNER(S) DEDICATES TO THE PUBLIC USE IN PERPETUITY THE STREETS AND EASEMENTS FOR UTILITIES AND DRAINAGE AS SHOWN ON THE SUBDIVISION PLAT. FOR VALUABLE CONSIDERATION THE UNDERSIGNED OWNER(S) HEREBY GRANTS UNTO SOUTHWESTERN ELECTRIC POWER COMPANY, BELL SOUTH TELECOMMUNICATIONS AND/OR ANY OTHER UTILITY, PUBLIC OR PRIVATE, THEIR RESPECTIVE SUCCESSORS OR ASSIGNS EXCLUSIVELY AND IN PERPETUITY, AS A COVENANT RUNNING WITH THE LAND THE RIGHT TO GO UPON THE EASEMENTS FOR UTILITIES HEREIN ESTABLISHED TO INSTALL, MAINTAIN AND REMOVE FACILITIES APPROPRIATE TO THEIR SERVICES, TO HAVE INGRESS AND EGRESS THERETO OVER ADJACENT LOTS AND LAND, TO TRIM AND/OR CUT AND REMOVE TREES OR OTHER OBSTRUCTIONS AS MAY INTERFERE WITH OR ENDANGER THE LIFE OR OPERATION OF SUCH FACILITIES OR THEIR EFFICIENCY, THE UNDERSIGNED OWNER(S) AGREES TO HOLD HARMLESS THE PARISH OF CADDO FOR DAMAGES DUE TO CHANGES IN THE STREET GRADES, BINDING HEREIN THEIR HEIRS AND ASSIGNS.

IT SHALL BE UNLAWFUL FOR LOTS TO BE SOLD IN THIS SUBDIVISION UNTIL ALL STREETS AND DRAINAGE SHOWN ON THIS PLAT ARE COMPLETED BY THE OWNER OR DEVELOPER, IT SHALL ALSO BE UNLAWFUL TO SELL ANY LOTS IN THIS SUBDIVISION UNTIL ALL SIDEWALKS, STREETLIGHTS, CENTRAL SEWER SYSTEMS AND WATER SYSTEMS ARE COMPLETED BY THE OWNER OR DEVELOPER IF REQUIRED BY THE SUBDIVISION REGULATIONS OF THE CADDO PARISH COMMISSION.

LOT 1000 AND 1001 ARE PRIVATELY OWNED COMMON AREAS WITH THE ENTIRETY OF EACH LOT SERVING AS A DRAINAGE EASEMENT.

PROPERTY WAS SURVEYED IN ACCORDANCE WITH THE L.A. "MINIMUM STANDARDS FOR PROPERTY BOUNDARY SURVEYS" FOR CLASS C SURVEY.

BASIS OF BEARINGS IS THE LOUISIANA COORDINATE SYSTEM OF 1983, NORTH ZONE.

SET 5/8" REBAR AT ALL PROPERTY CORNERS UNLESS SHOWN OTHERWISE.

FLOOD DESIGNATION=ZONE 'X', CADDO PARISH FLOOD INSURANCE RATE MAP NO. 22017C0335H  
 EFFECTIVE DATE : MAY 19, 2014

U.S. = UTILITY SERVITUDE  
 D.S. = DRAINAGE SERVITUDE  
 S.B. = SETBACK

APPROVED:

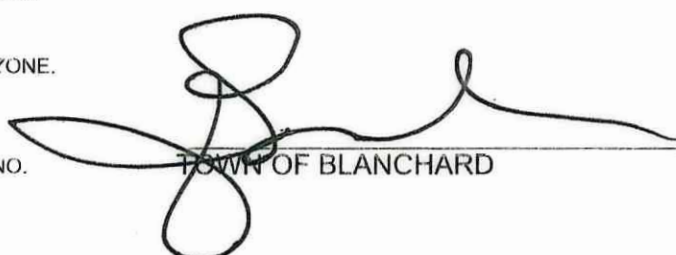
  
 TOWN OF BLANCHARD  
 1/27/2020  
 DATE

  
 CADDO PARISH DIRECTOR  
 OF PUBLIC WORKS  
 2-5-20  
 DATE

**RECORDED OWNERS:**

WASSON ROAD CO, L.L.C.

  
 BY: ROBERT M. AIELLO  
 OWNER  
 01/21/20  
 DATE



I HEREBY CERTIFY THAT THE PLAT OF THIS SUBDIVISION CONFORMS TO ALL REGULATIONS AND REQUIREMENTS OF THE SUBDIVISION ORDINANCE OF THE CADDO PARISH COMMISSION.

  
 KURT M. NIXON, P.L.S.  
 LA. LICENSE NUMBER 5072  
 01/16/2020  
 DATE

# BLANCHARD LAKE ESTATES UNIT 4

A SUBDIVISION LOCATED IN SECTION 34, TOWNSHIP 19 NORTH, RANGE 15 WEST, AND SECTION 3, TOWNSHIP 18 NORTH, RANGE 15 WEST IN CADDO PARISH, LOUISIANA CONTAINING 8.805 ACRES.

I HEREBY CERTIFY THAT THE PLAT OF THIS SUBDIVISION CONFORMS TO ALL REGULATIONS AND REQUIREMENTS OF THE SUBDIVISION ORDINANCE OF THE CADDO PARISH COMMISSION.

*Kurt M. Nixon* 01/16/2020  
 KURT M. NIXON, P.L.S. DATE  
 LA. LICENSE NUMBER 5072



0' 50' 100' 200'  
 SCALE: 1"=100'  
 DATE: JANUARY 2020

Curve Table					
Curve #	Length	Radius	Delta	Chord Direction	Chord Length
C1	40.45	25.00	92.71	N22° 13' 19"E	35.18
C2	6.12	170.00	2.06	S25° 09' 56"E	6.12
C3	37.19	25.00	85.22	S68° 48' 33"E	33.85
C4	42.81	25.00	98.10	N19° 31' 37"E	37.11
C5	35.73	25.00	81.90	S70° 28' 23"E	32.11
C6	18.82	200.00	5.39	N26° 49' 48"W	18.81

Parcel Line Table		
Line #	Length	Direction
L1	32.96	S89° 04' 02.18"E
L2	23.63	N88° 34' 43.82"E

Mike Spence, Caddo Clerk of Court



2777064 Pages: 2  
 02/07/2020 10:59 AM

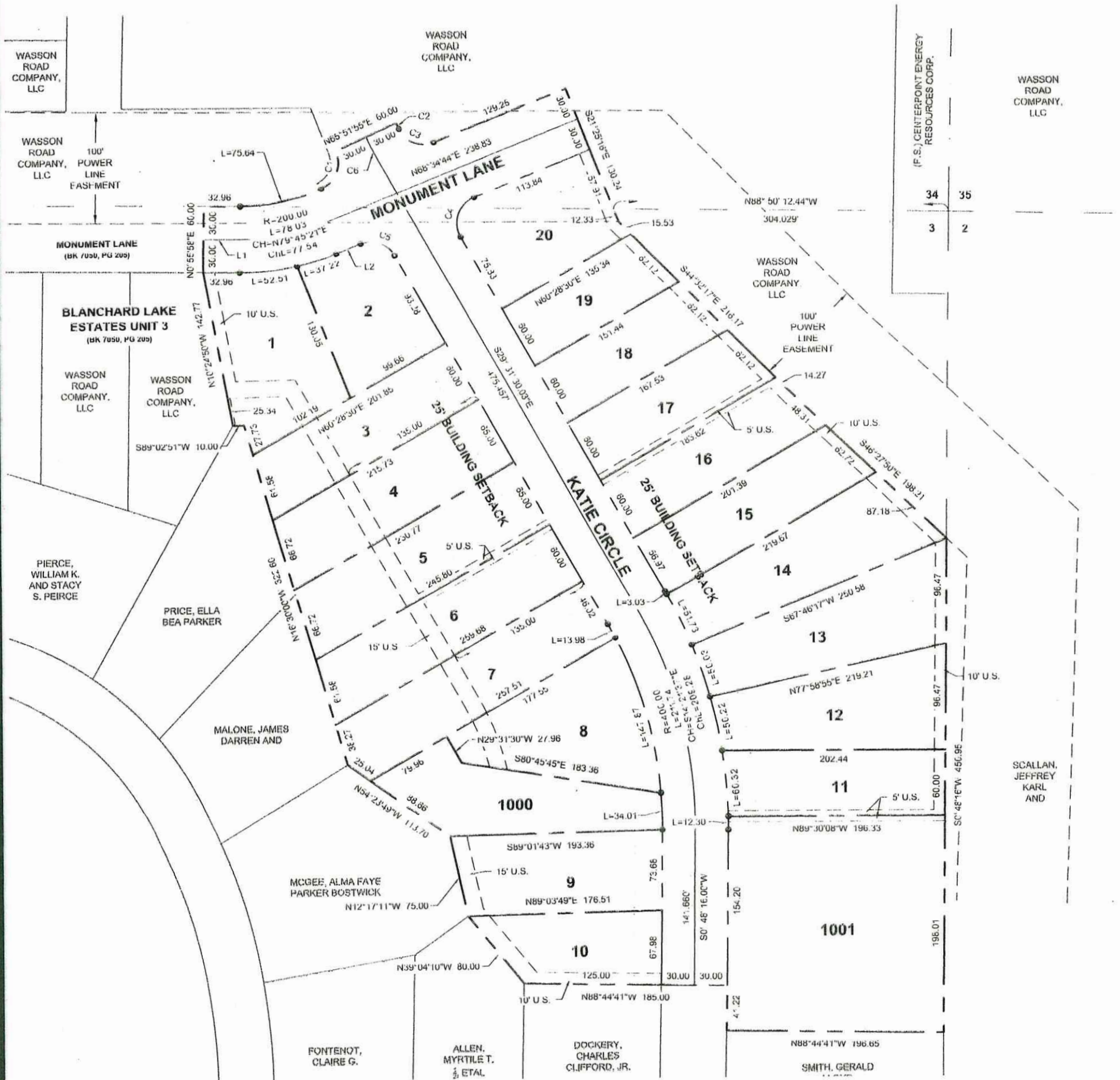

**ORDINANCE NO. 6196 OF 2022**

BY THE CADDO PARISH COMMISSION:

**AN ORDINANCE AMENDING THE BUDGET OF ESTIMATED REVENUES FOR THE AMERICAN RESCUE PLAN FUND TO PROVIDE AN APPROPRIATION FOR JUVENILE CENTER IN CADDO PARISH AND TO OTHERWISE PROVIDE WITH RESPECT THERETO**

WHEREAS, the American Rescue Plan Act of 2021 (ARPA) became law on March 11, 2021; and

WHEREAS, Caddo Parish Commission would like to appropriate a \$150,000 in 2022 and \$150,000 in 2023 to provide for funds to establish a Juvenile Center; and

WHEREAS, the Juvenile Center would provide a single point of entry for troubled youth and their families; and

WHEREAS, the Juvenile Center would provide **timely** and comprehensive assessments that link youth and families to the most appropriate community services; and

WHEREAS, the Juvenile Center would allow for the development and implementation of an integrated case management system or referral system for all clients by using a case management process that outlines intervention needs and plans, makes referrals to the indicated service, and monitors the service delivery and adjusting as needed; and

WHEREAS, the “one stop shop” approach allows the community partners to provide assessable, blended and comprehensive services to meet the needs of citizens and families. The model addresses the leading barriers to children and youth succeeding in the educational environment, while utilizing a team-based collaborative problem-solving approach among the agencies; and

WHEREAS, the appropriation was recommended by the American Rescue Plan Committee; and

NOW, THEREFORE, BE IT ORDAINED, by the Caddo Parish Commission in due, legal and regular session convened, that Budget of Estimated Revenues and Expenditures for the American Rescue Plan Fund for the year 2022 be amended as follows:

	<u>Budget Increase (Decrease)</u>
<b>American Rescue Plan Fund:</b>	
Expenditures:	
Federal Grant Expenditures	\$150,000

BE IT FURTHER ORDAINED, that if any provision or item of this ordinance or the application thereof is held invalid, such invalidity shall not affect other provisions, items or applications which can be given effect without the invalid provisions, items or applications, and to this end the provisions of this ordinance are hereby declared severable.

BE IT FURTHER ORDAINED, that this ordinance shall take effect upon adoption.

BE IT FURTHER ORDAINED, that all ordinances or parts thereof in conflict herewith are hereby repealed.

**Approved as to legal form:**

\_\_\_\_\_  
**Parish Attorney**

\_\_\_\_\_  
**Date**

# ORDINANCE AND RESOLUTION FACT SHEET

## CADDO PARISH COMMISSION

### TITLE

AN ORDINANCE AMENDING THE BUDGET OF ESTIMATED EXPENDITURES FOR THE AMERICAN RESCUE PLAN FUND AND TO OTHERWISE PROVIDE WITH RESPECT THERETO  
(Ordinance No. 6196 of 2022)

**ORIGINATING DEPARTMENT:** ARPA Committee

**BACKGROUND INFORMATION:** Amending the budget to include an appropriation for the of \$150,000 in 2022 and \$150,000 in 2023 for a Juvenile One Stop Center

The purpose of the Center is for area agencies and organizations to collaborate and provide vital services to families at one central location. The pooling of resources in the facility doesn't introduce new programs or services; rather, it reduces the length of time a juvenile must wait to have access to current community services, from several weeks to a matter of hours. Needs are addressed and determined with each juvenile based on data collected from an assessment process of testing and interviews. Information collected through this process assists staff in identifying the best approach to take with the juvenile and family. This process also makes every attempt to direct juveniles away from the juvenile justice system whenever possible, resulting in more productive outcomes for the youth and their families.

### **LIST OF SERVICES/AGENCIES TO BE OFFERED IN CENTER:**

#### **VYJ Programs:**

FINS (Families in Need of Services)

TASC (Truancy Assessment Service Center)

Conflict Resolution (School Fight Intervention/Prevention)

School Behavioral Referrals

Power of Choice (Youth Life-Skills and Parent Education)

Stamp Out Shoplifting (Theft Intervention/Prevention Program)

Mentoring

TBRI

Misdemeanor Referral Center (Serves as a clearinghouse for minor juvenile offenders)

CASA (Court Appointed Special Advocates)

#### **Agencies/Tenants:**

Caddo Parish D.A. Office – Child Support/Missing Persons

CHOICES (Mental Health Wrap-Around Services)

Center for Children and Families (Counseling – In home)

TEAMS (School Advocacy –Individualized Educational Program (IEP)

GED/HiSet Programs

High School Diploma Program

Workforce Development

Public Defender's Office attorneys

Substance Abuse Counseling/Testing

Tutoring/ACT Prep –We Tutor You & Centenary College Athletic Department  
Melanie Massey’s Physical Therapy – pediatric OT, PT, and Speech therapy  
Food Bank – SNAP benefits/meals for children’s activities  
CPJC – Substance Abuse counselors/parenting classes  
CPJC – Family Preservation Court staff/compliance officers  
CPSB Child Welfare & Attendance staff  
CPSB McKinney Vento staff  
DCFS Community Support

**Enrichment Activities:**

Computer Lab  
Summer Camps  
Health and Fitness activities and nutrition awareness (Centenary College Athletic Department)  
Uniform Closet (Porter’s Cleaners)  
Parenting Program  
After school tutoring program that also includes SEL (Social Emotional Learning) focus

**KEY STAFF CONTACT:** Hayley Barnett / Clay Walker

**AUTHORIZATION**

Department Head

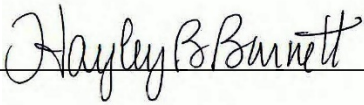
 \_\_\_\_\_

Date 02/09/2022

Legal

\_\_\_\_\_

Date \_\_\_\_\_

Parish Administrator

\_\_\_\_\_

Date \_\_\_\_\_

**ORDINANCE NO. 6197 OF 2022**

BY THE CADDO PARISH COMMISSION:

**AN ORDINANCE AMENDING THE BUDGET OF ESTIMATED REVENUES AND EXPENDITURES FOR THE RIVERBOAT FUND TO APPROPRIATE FUNDS FOR THE CADDO PARKS GRAB AND GO FEEDING PROGRAM AND TO OTHERWISE PROVIDE WITH RESPECT THERETO**

WHEREAS, Caddo Parish Parks and Recreation received the No Kid Hungry Grant for \$49,925 in 2021; and

WHEREAS, the Parks and Recreation department had huge success with feeding the youth that participated in the Parks and Recreation summer programs; and

WHEREAS, the No Kid Hungry Grant was not available in 2022; and

WHEREAS, the Caddo Parish Parks and Recreations department would like to continue the feeding program; and

WHEREAS, Caddo Parish Parks and Recreation would use these funds to provide pre-packaged summer/snacks and meals to participating youth during summer programming; and

WHEREAS, the NGO Committee recommended the appropriation; and

NOW, THEREFORE, BE IT ORDAINED, by the Caddo Parish Commission in due, legal and regular session convened, that Budget of Estimated Revenues and Expenditures for the Riverboat Fund for the year 2022 is hereby amended as follows:

Budget Increase (Decrease)

**Riverboat Fund**

Expenditures:

Summer Grab and Go Feeding Program	\$50,000
------------------------------------	----------

BE IT FURTHER ORDAINED, that if any provision or item of this ordinance or the application thereof is held invalid, such invalidity shall not affect other provisions, items or applications which can be given effect without the invalid provisions, items or applications, and to this end the provisions of this ordinance are hereby declared severable.

BE IT FURTHER ORDAINED, that this ordinance shall take effect upon adoption.

BE IT FURTHER ORDAINED, that all ordinances or parts thereof in conflict herewith are hereby repealed.

Approved as to legal form:

\_\_\_\_\_  
Parish Attorney

\_\_\_\_\_  
Date

**ORDINANCE AND RESOLUTION FACT SHEET**

**CADDO PARISH COMMISSION**

<b>TITLE</b>	
ORDINANCE AMENDING THE 2022 BUDGET OF ESTIMATED REVENUES AND EXPENDITURES FOR THE RIVERBOAT FUND TO APPROPRIATE \$50,000 TO A GRAB AND GO FEEDING PROGRAM THROUGH CADDO PARKS AND RECREATION  (Ordinance No. 6197 of 2022)	
<b>ORIGINATING DEPARTMENT:</b> NGO Committee	
<b>BACKGROUND INFORMATION:</b> Amending the budget of Estimated Revenues and Expenditures for the Riverboat Fund to appropriate \$50,000 to purchase snacks and meals for Caddo youth that participate in summer programs.	
<b>KEY STAFF CONTACT:</b> Patrick Wesley / Hayley Barnett	
<b>AUTHORIZATION</b>	
Department Head	<u>Hayley B. Barnett</u> Date 2/9/2022
Legal	_____ Date _____
Parish Administrator	_____ Date _____



## **PARKS & RECREATION**

### **REQUEST FOR AMERICAN RESCUE PLAN ACT FUNDS**

Caddo Parish Parks and Recreation Department is requesting \$50,000 American Rescue Plan Act (ARPA) funds to facilitate a **“Grab and Go Feeding Program”** (snacks, lunches and after-school meals) for Caddo Parish youth, ages 4-17 who participate in 2022 recreation/wellness, athletic and nature education programs. This program was funded in 2021 through a grant award by National Recreation and Parks Association (NRPA), serving 8,160 Caddo Parish youth. This grant will not be available for the 2022 calendar year.

If approved, the “Grab and Go Feeding Program” will be a continued "game changer" in how Caddo Parish Parks and Recreation deliver quality programs and services to our Caddo Parish youth. It was evident through last year’s feeding program, that there is a vital need in Caddo Parish to provide healthy snacks and meals to our youth program participants. Many of our youth participants and respective parents expressed their sincere appreciation of Caddo Parish and highly recommended that our parks department provide this feeding program model and service annually.

Participating Caddo Parish youth will not only receive healthy grab and go snacks, lunches and after-school meals, they will also be able to participate in invaluable recreational activities, health and wellness activities, crime prevention programs, nature education programs and sport camps/clinics.

Caddo Parish Parks and Recreation Department staff, certified instructors and volunteer coaches continue to emphasize how last year’s feeding program made a significant impact in Caddo Parish. Many youth attended our recreational and athletic programs without having an adequate breakfast, snack or lunch throughout the day. Furthermore, when snacks, lunch or meals were served at our programs, some youth did not eat their entire snack, lunch or meal; but saved their food for later-because many times there was no food at their respective homes and our provided food would be there last meal for the day.

#### **Local/State Food Insecurity Statistics:**

- According to Center for Planning Excellence, over 33% of Shreveport households are now experiencing food insecurity. The national rate is 16%.
- According to Urban Footprint, communities of color are at a significantly high risk of becoming food insecure. In Louisiana, 23% of Black households are food insufficient compared with 7% of white households.

**ARPA Eligible:**

Proposed “Grab and Go Feeding Program” will place emphasis on the following:

- Public Health
- Promoting healthy childhood/youth environments
- Promoting outdoor learning and play, beyond the school day (Out-of-School Time)
- Promoting outdoor recreation and socialization to mitigate the spread of COVID-19

**(Budget Breakdown)**

**Food:**

\$35,000 (food/consumables)

**Equipment/PPE:**

\$5,000 (Gloves, masks, hand sanitizer stations, cleaning/disinfectant supplies, trash receptacles, drink coolers, food bags, tables, tents, serving utensils, warmers, etc.)

**Marketing/Promotions of Feeding Program (year-round):**

\$10,000 (radio buys, social media campaign ads, flyers, banners/signage, rack cards, etc.)

**Total Amount Requesting:**

**\$50,000.00**

**2022 Youth Programs Offered**

**(Athletics, Health and Wellness)**

Sport camps/clinics, football, basketball, baseball, Jiu-Jitsu, soccer, lacrosse, softball, track and field, weightlifting, fitness training and e-sports league.

**Estimated # of Participants**

**5,000**

**(Recreation / Education)**

Crime prevention workshops, after-school and related community outreach programs via churches and/or youth non-profit organizations.

**6,000**

**(Nature Education)**

Wild Child Summer Camps (6 sessions), Get Hooked on Fishing events, canoeing, archery activities park clean-ups and community garden activities.

**4,000**

**Estimated Number of Program Participants to be Served in 2022: 15,000**

**Estimated Number of Meals to be Served in 2022: 17,000 – 18,000**

**Compliance:**

Caddo Parish Parks and Recreation staff will comply with all required reporting guidelines.

**Program/Activity Feeding Sites:**

- Caddo Parks
- Caddo Schools
- Caddo Common Park
- Area Churches
- Lee Hedges Stadium
- Independence Stadium
- Boys and Girls Club
- Centenary College (Athletic Venues)
- Princess Park
- Holy Angels
- Town of Greenwood
- Town of Mooringsport
- Town of Vivian

**Food Vendors Used:**

- Dillas Quesadilla
- Jason's Deli
- Pizza Hut
- Raising Cane's
- Sam's Club
- Subway
- Whataburger

**Revised: 2-11-22**

**ORDINANCE NO. 6198 OF 2022**

BY THE CADDO PARISH COMMISSION:

**AN ORDINANCE AMENDING THE BUDGET OF ESTIMATED REVENUES AND EXPENDITURES FOR THE RIVERBOAT FUND FOR THE YEAR 2022 TO PROVIDE AN ADDITIONAL APPROPRIATION OF \$15,000 FOR ROBINSON'S RESCUE AND TO OTHERWISE PROVIDE WITH RESPECT THERETO**

WHEREAS, the Non-Governmental Organizations Committee of the Caddo Parish Commission recommended the Commission provide an appropriation of an additional \$15,000 for Robinson's Rescue; and

WHEREAS, the mission of Robinson's Rescue is to eliminate euthanasia of dogs and cats in Northwest Louisiana via an aggressive, comprehensive spay and neuter program; and

WHEREAS, Robinson's Rescue, since its inception, has partnered with the Caddo Parish Commission to provide low cost, high quality spay and neuter surgeries for pets belonging to citizens of Caddo Parish; and

WHEREAS, Robinson's Rescue's 2022 appropriation is \$35,000, a reduction of \$15,000 from the 2020 appropriation; and

WHEREAS, the NGO Committee recommends increasing Robinson's Rescue's 2022 appropriation from \$35,000 to \$50,000; and

WHEREAS it is necessary to amend the 2022 Budget to provide an additional appropriation of \$15,000 for Robinson's Rescue; and

NOW, THEREFORE, BE IT ORDAINED, by the Caddo Parish Commission in due, legal and regular session convened, that Budget of Estimated Revenues and Expenditures for the Riverboat Fund for the year 2022 is hereby amended as follows:

	<u>Budget Increase (Decrease)</u>
<u>Riverboat Fund</u>	
NGO Appropriations – Robinson's Rescue	\$15,000
Fund Balance	(\$15,000)

BE IT FURTHER ORDAINED, that if any provision or item of this ordinance or the application thereof is held invalid, such invalidity shall not affect other provisions, items or applications which can be given effect without the invalid provisions, items or applications, and to this end the provisions of this ordinance are hereby declared severable.

BE IT FURTHER ORDAINED, that this ordinance shall take effect upon adoption.

BE IT FURTHER ORDAINED, that all ordinances or parts thereof in conflict herewith are hereby repealed.

Approved as to legal form:

\_\_\_\_\_  
Parish Attorney

\_\_\_\_\_  
Date

**ORDINANCE AND RESOLUTION AUTHORIZATION FORM**

**CADDO PARISH COMMISSION**

**TITLE**

ORDINANCE AMENDING THE 2022 BUDGET OF ESTIMATED REVENUES AND EXPENDITURES FOR THE RIVERBOAT FUND TO PROVIDE AN ADDITIONAL APPROPRIATION FOR ROBINSON RESCUE AND TO OTHERWISE PROVIDE WITH RESPECT THERETO

**(Ordinance No. 6198 of 2022)**

**ORIGINATING DEPARTMENT:** NGO Committee

**BACKGROUND INFORMATION:** Amending the 2022 budget of Estimated Revenues and Expenditures for the Riverboat Fund to provide an additional \$15,000 to Robinson Rescue.

**KEY STAFF CONTACT:** Hayley Barnett

**AUTHORIZATION**

Department Head Hayley Barnett Date 2/9/2022

Legal \_\_\_\_\_ Date \_\_\_\_\_

Parish Administrator \_\_\_\_\_ Date \_\_\_\_\_

**ORDINANCE NO. 6199 OF 2022**

BY THE CADDO PARISH COMMISSION:

**AN ORDINANCE AMENDING THE BUDGET OF ESTIMATED REVENUES AND EXPENDITURES FOR THE RIVERBOAT FUND FOR THE YEAR 2022 TO PROVIDE AN APPROPRIATION TO PROVIDE BALLISTIC VESTS FOR SHREVEPORT AND CADDO PARISH FIRE DISTRICTS, AND TO OTHERWISE PROVIDE WITH RESPECT THERETO**

WHEREAS, the local fire departments are called to most all emergencies in the community many of which that do not involve a fire; and

WHEREAS, many of these emergencies are to rescue or assist victims or violence, including shootings; and

WHEREAS, local police officers are equipped ballistic vest; and

WHEREAS, local fire fighters are not equipped with ballistic vest; and

WHEREAS, many of the fire districts do not have the funds to pay for this type equipment and the Fire Districts are seeking assistance from the Caddo Parish Commission to purchase ballistic vest; and

WHEREAS, the Caddo Parish Commission originally appropriated funds for the ballistic vest with Ordinance 6109 of 2021; and

WHEREAS, the original appropriation lapsed and needs to be re-appropriated; and

WHEREAS, the Caddo Parish Commission would like to appropriate funds to purchase ballistic vest for our local Shreveport and Caddo Fire Districts; and

NOW, THEREFORE, BE IT ORDAINED, by the Caddo Parish Commission in due, legal and regular session convened, that Budget of Estimated Revenues and Expenditures for the Riverboat Fund for the year 2022 is hereby amended as follows:

	<u>Budget Increase (Decrease)</u>
<b>Riverboat Fund</b>	
Allocations to Other Entities	
Fire Districts – Ballistic Vest	\$130,700
Fund Balance	\$(130,700)

BE IT FURTHER ORDAINED, that if any provision or item of this ordinance or the application thereof is held invalid, such invalidity shall not affect other provisions, items or applications which can be given effect without the invalid provisions, items or applications, and to this end the provisions of this ordinance are hereby declared severable.

BE IT FURTHER ORDAINED, that this ordinance shall take effect upon adoption.

BE IT FURTHER ORDAINED, that all ordinances or parts thereof in conflict herewith are hereby repealed.

**Approved as to legal form:**

**Parish Attorney**

**Date**

**ORDINANCE AND RESOLUTION FACT SHEET**

**CADDO PARISH COMMISSION**

<b>TITLE</b>	
ORDINANCE AMENDING THE 2022 BUDGET OF ESTIMATED REVENUES AND EXPENDITURES FOR THE RIVERBOAT FUND TO APPROPRIATE \$130,696 FOR BALLISTIC VEST FOR FIREMEN  (Ordinance No. 6199 of 2022)	
<b>ORIGINATING DEPARTMENT:</b> Commissioner Taliaferro	
<b>BACKGROUND INFORMATION:</b> Amending the budget of Estimated Revenues and Expenditures for the Riverboat Fund for an appropriation for ballistic vest for fireman.  Re-appropriation of funds that lapsed.  Original ordinance was for \$165,300 for 172 vests. This ordinance is for \$130,700 for 136 vests. 36 vests were purchased when the new fire trucks were purchased.	
<b>KEY STAFF CONTACT:</b> Hayley Barnett	
<b>AUTHORIZATION</b>	
Department Head	<u>Hayley B Barnett</u> Date 2/10/22
Legal	_____ Date _____
Parish Administrator	_____ Date _____

**ORDINANCE NO. 6200 of 2022**

BY THE CADDO PARISH COMMISSION:

AN ORDINANCE TO ESTABLISH A TEMPORARY PARISH PLANNING AND ZONING COMMISSION, TO PROVIDE FOR ITS MEMBERSHIP, TO PROVIDE FOR AN EFFECTIVE DATE, AND TO OTHERWISE PROVIDE WITH RESPECT THERETO

WHEREAS, Act 294 of 2020 removed Caddo Parish from the Shreveport Caddo Metropolitan Planning Commission effective January 1, 2022;

WHEREAS, Article VI, Section 17 authorizes local governments to adopt regulations for land use and zoning;

WHEREAS, that section also authorizes creation of commissions to implement those regulations;

WHEREAS, Article VI, Section 5 provides for the adoption of home rule charters by local governments and the exercise by such home rule charter governments of all powers and functions not denied them by the constitution or by general state law and of all powers and functions granted to local governmental subdivisions by other provisions of the Constitution;

WHEREAS, the state statutes regarding planning and zoning by local governments provide for the establishment of a planning and zoning commission with between *five* and nine members;

WHEREAS, populating the planning and zoning commission established by the Caddo Parish Commission via Ordinance 6071 of 2022 has stalled pending a requested Attorney General's opinion on the matter;

WHEREAS, not having a parish planning and zoning commission has resulted in delays in all forms of development which require planning and zoning recommendation and approval;

WHEREAS, the Caddo Parish Commission wishes to provide a temporary process wherein development can proceed until it makes a permanent decision on populating the planning and zoning commission created via Ordinance 6071 of 2021;

NOW, THEREFORE, BE IT ORDAINED, by the Caddo Parish Commission in due, legal and regular session convened, that a temporary Caddo Parish Planning and Zoning Commission is hereby created as provided herein.

BE IT FURTHER ORDAINED, that the Caddo Parish Planning Commission shall consist of five members selected from the names that have been submitted to the Caddo Parish Commission as of February 14, 2022. The Parish Commission may only remove any member of the temporary commission, after public hearing, for inefficiency, neglect of duty, or malfeasance in office. The Temporary Caddo Parish Planning Commission may by rule or bylaw provide for such officers and establish such rules and procedures as it deems appropriate.

BE IT FURTHER ORDAINED, that the Temporary Caddo Parish Planning and Zoning Commission shall be created and be in existence as of March 3, 2022 and shall exist until June 30, 2022. The Temporary Commission shall hear all planning and zoning matters and make recommendations to the Caddo Parish Commission as all current zoning ordinances require, and shall assume all duties and authority as provided by state law of a planning and zoning commission.

BE IT FURTHER ORDAINED, that if any provision or item of this ordinance or the application thereof is held invalid, such invalidity shall not affect other provisions, items or applications which can be given effect without the invalid provisions, items or applications, and to this end the provisions of this ordinance are hereby declared severable.

BE IT FURTHER ORDAINED, that this ordinance shall take effect upon adoption.

BE IT FURTHER ORDAINED, that all ordinances or parts thereof in conflict herewith, are hereby repealed.

Approved as to legal form:

---

Parish Attorney

---

Date

**ORDINANCE AND RESOLUTION FACT SHEET**

**CADDO PARISH COMMISSION**

TITLE	
Ordinance No. 6200 of 2022	
<p>A AN ORDINANCE TO ESTABLISH A TEMPORARY PARISH PLANNING AND ZONING COMMISSION, TO PROVIDE FOR ITS MEMBERSHIP, TO PROVIDE FOR AN EFFECTIVE DATE, AND TOOTHERWISE PROVIDE WITH RESPECT THERETO</p>	
DATE 2/14/2021	ORIGINATING DEPARTMENT: Legal for Commissioners Chavez and Johnson
<b>BACKGROUND INFORMATION</b>	
<p>There is currently a backlog of zoning permits and approvals because Caddo Parish has not put its planning and zoning board in place, pending an Attorney General opinion on the process that must be followed now that the parish is no longer part of the MPC. Putting this commission in place temporarily allows matters to be addressed pending receipt of the Attorney General opinion. The temporary commission can be dissolved sooner if the opinion arrives before June 30, 2022.</p>	
<b>FINANCIAL IMPACT AND SOURCE OF FUNDING</b>	
None	
<b>EFFECT(S) OF PROPOSED ACTION</b>	
Places the temporary commission in place to hear back logged cases and allow development in the parish to move forward.	
<b>ALTERNATIVES/STAFF RECOMMENDATION</b>	
Do not place a temporary commission; backlog continues. Staff recommends seating a commission.	
<b>KEY STAFF CONTACT</b>	
Donna Frazier, Parish Attorney	
<b>COORDINATION</b>	
Department Head	(Initial) <i>Dys</i>
Parish Attorney	(Initial) <i>Dys</i>
Parish Administrator/CEO	(Initial) <i>WJ</i>

**ORDINANCE NO. 6021 of 2022**

BY THE CADDO PARISH COMMISSION:

AN ORDINANCE AMENDING ORDINANCE 6071 OF 2021 TO ESTABLISH A PARISH PLANNING AND ZONING COMMISSION, TO PROVIDE FOR ITS MEMBERSHIP, TO PROVIDE FOR AN EFFECTIVE DATE, AND TO OTHERWISE PROVIDE WITH RESPECT THERETO

WHEREAS, Act 294 of 2020 removed Caddo Parish from the Shreveport Caddo Metropolitan Planning Commission effective January 1, 2022;

WHEREAS, Article VI, Section 17 authorizes local governments to adopt regulations for land use and zoning;

WHEREAS, that section also authorizes creation of commissions to implement those regulations;

WHEREAS, Article VI, Section 5 provides for the adoption of home rule charters by local governments and the exercise by such home rule charter governments of all powers and functions not denied them by the constitution or by general state law and of all powers and functions granted to local governmental subdivisions by other provisions of the Constitution;

WHEREAS, the state statutes regarding planning and zoning by local governments provide for the establishment of a planning and zoning commission with between *five* and nine members;

WHEREAS, the Caddo Parish Commission wishes to establish a planning and zoning commission for the unincorporated areas of Caddo Parish;

WHEREAS, the upcoming transition requires that the planning and zoning commission be created prior to January 1, 2022 and undertake certain preliminary matters prior to that date;

NOW, THEREFORE, BE IT ORDAINED, by the Caddo Parish Commission in due, legal and regular session convened, that the Caddo Parish Planning Commission is hereby created as provided herein.

BE IT FURTHER ORDAINED, that the Caddo Parish Planning Commission shall consist of five members appointed by the Caddo Parish Commission. ~~Four of the five~~ members shall be residents of Caddo Parish whose primary domicile is in Caddo Parish and is outside the boundaries of an incorporated municipality. Due to the proximity of the incorporated and unincorporated areas, and the less rigidly defined and meandering nature of its boundaries, at least one member of the planning board "may" be appointed from an incorporated area. The members shall serve terms of four years. The Parish Commission may only remove any member of the commission, after public hearing, for inefficiency, neglect of duty, or malfeasance in office. The Caddo Parish Planning Commission may by rule or bylaw provide for such officers and establish such rules and procedures as it deems appropriate.

BE IT FURTHER ORDAINED that the initial five members shall serve terms of one, two, three, and four years such that one initial member serves a one-year term, one initial member serves a two year term, one initial member serves a three year term, and two initial members serve four year terms. The terms of the initial members shall be assigned by random drawing.

BE IT FURTHER ORDAINED that the Caddo Parish Planning Commission shall be created and be in existence as of July 1, 2021. The Caddo Parish Planning Commission shall assume all duties and authority as provided by state law of a planning and zoning commission on January 2, 2022. The Caddo Parish Planning Commission shall serve in an advisory capacity prior to January 2, 2022 regarding proposals for planning and subdivision and zoning ordinances to take effect on or after January 2, 2022.

BE IT FURTHER ORDAINED, that if any provision or item of this ordinance or the application thereof is held invalid, such invalidity shall not affect other provisions, items or applications which can be given effect without the invalid provisions, items or applications, and to this end the provisions of this ordinance are hereby declared severable.

BE IT FURTHER ORDAINED, that this ordinance shall take effect upon adoption.

BE IT FURTHER ORDAINED, that all ordinances or parts thereof in conflict herewith, are hereby repealed.

Approved as to legal form:

---



Parish Attorney

---

Date

**ORDINANCE AND RESOLUTION FACT SHEET**

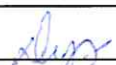
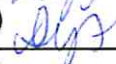
**CADDO PARISH COMMISSION**

<b>TITLE</b>	
<b>ORDINANCE NO. 6021 of 2022</b>	
AN ORDINANCE AMENDING ORDINANCE 6071 OF 2021 TO ESTABLISH A PARISH PLANNING AND ZONING COMMISSION, TO PROVIDE FOR ITS MEMBERSHIP, TO PROVIDE FOR AN EFFECTIVE DATE, AND TO OTHERWISE PROVIDE WITH RESPECT THERETO	
DATE 2/14/2021	ORIGINATING DEPARTMENT: Legal for Commissioner Burrell
<b>BACKGROUND INFORMATION</b>	
This amendment would provide for an at-large appointee to the Caddo Parish Planning/Zoning Commission, who could be appointed from anywhere within the parish.	
<b>FINANCIAL IMPACT AND SOURCE OF FUNDING</b>	
None	
<b>EFFECT(S) OF PROPOSED ACTION</b>	
See background information above.	
<b>ALTERNATIVES/STAFF RECOMMENDATION</b>	
Do not pass resolution; staff has no recommendation.	
<b>KEY STAFF CONTACT</b>	
Donna Frazier, Parish Attorney	
<b>COORDINATION</b>	
Department Head	(Initial) 
Parish Attorney	(Initial) 
Parish Administrator/CEO	(Initial) 

**ORDINANCE NO. 6202 of 2022**

BY THE CADDO PARISH COMMISSION:

AN ORDINANCE TO AUTHORIZE THE ADMINISTRATOR TO EXECUTE AN PREDIAL SERVITUDE OF PASSAGE AND RIGHT TO USE OVER PARISH PROPERTY LOCATED IN SOUTHWESTERN QUARTER OF SECTION 28, TOWNSHIP 22 NORTH RANGE 16 WEST AND TO OTHERWISE PROVIDE WITH RESPECT THERETO.

WHEREAS, the Parish of Caddo has received a request to grant to Philip Blakeman as the owner of landlocked property adjacent to parish property a right of way on the western edge of the Old Vivian Landfill property.

WHEREAS, the Parish of Caddo has reviewed the request and determined it is in the best interest of the Parish of Caddo to approve said request.

WHEREAS, Philip Blakeman has agreed to pay the Parish for the granting of the servitude of passage as depicted on the plat attached as Exhibit "A"

NOW, THEREFORE, BE IT ORDAINED, by the Caddo Parish Commission in due, legal and regular session convened, that the Parish Administrator or his designated representative shall be and is hereby, authorized to execute an predial servitude of passage and right to use over a portion of the Old Vivian Landfill property as depicted in Exhibit "A" for the purposes of ingress and egress to landlocked property adjacent to parish property.

BE IT FURTHER ORDAINED, that if any provision or item of this ordinance or the application thereof is held invalid, such invalidity shall not affect other provisions, items or applications which can be given effect without the invalid provisions, items or applications, and to this end the provisions of this ordinance are hereby declared severable.

BE IT FURTHER ORDAINED, that this ordinance shall take effect upon adoption.

BE IT FURTHER ORDAINED, that all ordinances or parts thereof in conflict herewith are hereby repealed.

**Approved as to legal form:**

\_\_\_\_\_  
**Parish Attorney**

\_\_\_\_\_  
**Date**

**NORTHWESTERN LAND DISTRICT**  
LOUISIANA MERIDIAN

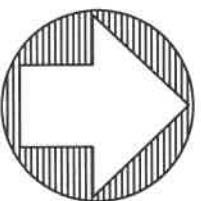

**NORTH**



CADDO PARISH ROAD 154  
(VIVIAN AIRPORT ROAD)  
FND. 3/4" IRON PIPE  
FND. 1/2" IRON ROD

OWNER:  
WILLIE DANIELS, JR.

OWNER:  
E.H. WHITE  
LAND &  
TIMBER CO., LLC

N02°03'07"E 1913.14'  
S02°03'07"W 1907.55'

OWNER: CADDO PARISH COMMISSION

**30' WIDE SERVITUDE**

**OF PASSAGE**

1.316 ACRES



POINT OF BEGINNING  
FND. 5/8" IRON ROD

S29 S32 S33  
T22N-R16W  
N89°38'21"W 30.01'  
OWNER: PHILLIP BLAKEMAN

- NOTES:
1. BEARINGS ARE GRID, STATE PLANE, LOUISIANA NORTH ZONE, NAD83 AS OBTAINED BY GPS OBSERVATIONS UTILIZING THE CAGNET NRTK.
  2. OWNERSHIP INFORMATION SHOWN HEREON IS BASED SOLELY UPON INFORMATION FROM THE CADDO PARISH TAX ASSESSOR WEBSITE.
  3. THIS SURVEY DOES NOT CONSTITUTE A TITLE SEARCH BY THE SURVEYOR. THIS SURVEY WAS MADE WITHOUT THE BENEFIT OF A TITLE COMMITMENT. SURVEYOR HAS NOT MADE ANY INVESTIGATIVE SEARCH FOR TITLE EVIDENCE, ENCUMBRANCES, SERVITUDES, RESTRICTIVE COVENANTS, LIENS OR ANY OTHER FACT THAT A CURRENT TITLE SEARCH MAY DISCLOSE.
  4. ANY UTILITIES AND/OR ADDITIONAL SERVITUDES THAT MAY EXIST WITHIN THIS PROPERTY ARE NOT SHOWN HEREON.

**LEGAL DESCRIPTION FOR A 30' WIDE SERVITUDE OF PASSAGE:**

A 30' WIDE SERVITUDE OF PASSAGE ACROSS THE SOUTHWEST QUARTER OF SECTION 28, LYING EAST OF AND ADJACENT TO THE COMMON LINE BETWEEN SECTIONS 29 AND 28, EXTENDING SOUTHERLY FROM THE SOUTH RIGHT OF WAY LINE OF VIVIAN AIRPORT ROAD TO THE NORTH LINE OF SECTION 33, ALL IN TOWNSHIP 22 NORTH, RANGE 16 WEST, CADDO PARISH, LOUISIANA, SAID SERVITUDE BEING MORE PARTICULARLY DESCRIBED AS FOLLOWS:

BEGIN AT A 5/8" IRON ROD AT THE CORNER COMMON TO SECTIONS 28, 29, 32 AND 33, TOWNSHIP 22 NORTH, RANGE 16 WEST, CADDO PARISH, LOUISIANA, BEING THE POINT OF BEGINNING OF THE TRACT HEREIN DESCRIBED:  
 THENCE NORTH 02°03'07" EAST A DISTANCE OF 1,913.14 FEET ALONG THE COMMON LINE BETWEEN SAID SECTIONS 28 AND 29 TO THE SOUTH RIGHT OF WAY LINE OF PARISH ROAD 154 (VIVIAN AIRPORT ROAD);  
 THENCE SOUTH 79°02'21" EAST A DISTANCE OF 30.37 FEET ALONG SAID SOUTH RIGHT OF WAY LINE;  
 THENCE SOUTH 02°03'07" WEST A DISTANCE OF 1907.55 FEET TO THE COMMON LINE BETWEEN SAID SECTION 28 AND 33;  
 THENCE NORTH 89°38'21" WEST A DISTANCE OF 30.01 FEET ALONG SAID COMMON LINE TO THE POINT OF BEGINNING.

SAID 30' WIDE SERVITUDE OF PASSAGE HEREIN DESCRIBED CONTAINING 57,310 SQUARE FEET OR 1.316 ACRES, MORE OR LESS.

I certify that this map represents an actual ground survey prepared under my direct supervision in accordance with the applicable La. standards of practice for a route survey.

**MOHR AND ASSOCIATES, INC.** Date  
 Jordinie A. Craig  
 Registered Professional Land Surveyor  
 Registration No. 4587



**Mohr and Associates, Inc.**  
 Consulting Civil Engineers & Land Surveyors  
 1324 N. Hearne Ave., Ste 301 Phone: (318) 686-7190  
 Shreveport, Louisiana 71107 Fax: (318) 402-4400

FOR: Phillip Blakeman	Date	Job	Scale	Drawn
Proposed Servitude of Passage	1-27-2021	37866	1"=200'	B. ANDERSON

1/29/2021 8:12:45 AM V:\SURVEYS\BLAKEMAN, PHILLIP\DRAWINGS\37866-BMAP.DWG

**ORDINANCE FACT SHEET  
CADDO PARISH COMMISSION**

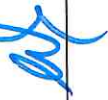
<p>Ordinance 6202 of 2022</p>	<p><b>TITLE</b></p>	<p>AN ORDINANCE TO AUTHORIZE THE ADMINISTRATOR TO EXECUTE AN PREDIAL SERVITUDE OF PASSAGE AND RIGHT TO USE OVER PARISH PROPERTY LOCATED IN SOUTHWESTERN QUARTER OF SECTION 28, TOWNSHIP 22 NORTH RANGE 16 WEST AND TO OTHERWISE PROVIDE WITH RESPECT THERETO</p>
<p><b>DATE:</b> February 10, 2022</p>	<p><b>ORIGINATING DEPARTMENT:</b> Legal for Public Works</p>	
<p><b>BACKGROUND INFORMATION</b></p>		
<p>Philip Blakeman is the owner of 80 acres of land in the West half of the Northwest Quarter Section 33. Township 22 North, Range 16 West, Caddo Parish, Louisiana. That tract is landlocked and does not have access to a public road. Under the law, he is entitled to a right of passage over neighboring property to a public road. The Parish is willing to grant him that a 30 foot right of way on the west side of the Old Vivian Landfill tract. He has agreed to install fencing along the right of way and install drains as stipulated by Dept. of Public Works across any road he constructs. Additionally, he has agreed to compensate the Parish for that right of way/right of passage.</p>		
<p><b>FINANCIAL IMPACT AND SOURCE OF FUNDING</b></p>		
<p>There is no financial impact to the Parish as Philip Blakeman will pay the Parish for the right of passage.</p>		
<p><b>EFFECT(S) OF PROPOSED ACTION</b></p>		
<p>The grant of the right of passage will create a road along the west edge of the Parish's property. This will not interfere with the Parish's use of the remainder of the property.</p>		
<p><b>ALTERNATIVES/STAFF RECOMMENDATION</b></p>		
<p>Refuse to grant the right of passage and force the owner to sue the Parish for what he is legally entitled to have. Staff recommends granting the right of passage/right of way.</p>		
<p><b>KEY STAFF CONTACT</b></p>		
<p>Henry M. Bernstein, Assistant Parish Attorney; Jimmy Whittington, Public Works</p>		
<p><b>COORDINATION</b></p>		
<p>Department Head</p>		<p>(Initial) <i>HMB</i></p>
<p>Parish Administrator/CEO</p>		<p>(Initial) <i>aj</i></p>

**ORDINANCE NO. 6203 of 2022**

BY THE CADDO PARISH COMMISSION:

AN ORDINANCE TO AUTHORIZE THE ADMINISTRATOR TO EXECUTE AN EASEMENT AND RIGHT-OF-WAY AGREEMENT WITH CADDEAUX GATHERING, LLC REGARDING A PIPELINE THROUGH AND UNDER PARISH PROPERTY LOCATED IN SECTION 7, TOWNSHIP 18 NORTH, RANGE 15 WEST, CADDO PARISH, LOUISIANA, AND TO OTHERWISE PROVIDE WITH RESPECT THERETO.

WHEREAS, the Parish of Caddo had received a request to grant to Caddeaux Gathering, LLC a permanent easement and right-of-way (as depicted on Exhibit "A") in Section 7, Township 18 North, Range 15 West, Caddo Parish, Louisiana to install a pipeline for the transportation of oil, natural gas, other gases, liquids, hydrocarbons or mixtures of the foregoing;

WHEREAS, the pipeline will be installed entirely by subsurface boring which means that the surface of the property will remain undisturbed;

WHEREAS, the Parish of Caddo has reviewed the request and determined it is in the best interest of the Parish of Caddo to approve said request;

WHEREAS, Caddeaux Gathering, LLC has agreed to pay the Parish for the easement and right of way; and

WHEREAS, Caddeaux Gathering, LLC has provided the Parish with a plat showing the final location of the easement and right-of-way which is attached as Exhibit A.

NOW, THEREFORE, BE IT ORDAINED, by the Caddo Parish Commission in due, legal and regular session convened, that the Parish Administrator or his designated representative shall be and is hereby, authorized to execute an easement and right-of-way for the installation of a pipeline as depicted on Exhibit "A".

BE IT FURTHER ORDAINED, that if any provision or item of this ordinance or the application thereof is held invalid, such invalidity shall not affect other provisions, items or applications which can be given effect without the invalid provisions, items or applications, and to this end the provisions of this ordinance are hereby declared severable.

BE IT FURTHER ORDAINED, that this ordinance shall take effect upon adoption.

BE IT FURTHER ORDAINED, that all ordinances or parts thereof in conflict herewith are hereby repealed.

**Approved as to legal form:**

\_\_\_\_\_  
**Parish Attorney**

\_\_\_\_\_  
**Date**

**EXHIBIT "A"**  
**CADDO PARISH, LA**  
**SECTION 7, T18N-R15W**  
**LOUISIANA MERIDIAN**

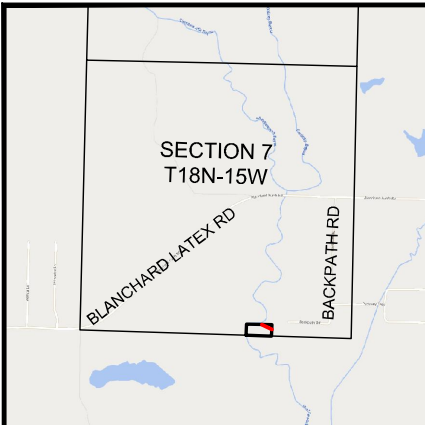

VICINITY MAP  
N.T.S.

LA-CD-CY-003.000  
 KEN LAWLER BUILDERS, INC.  
 DOCUMENT # 1554274  
 C.R.C.P.L.

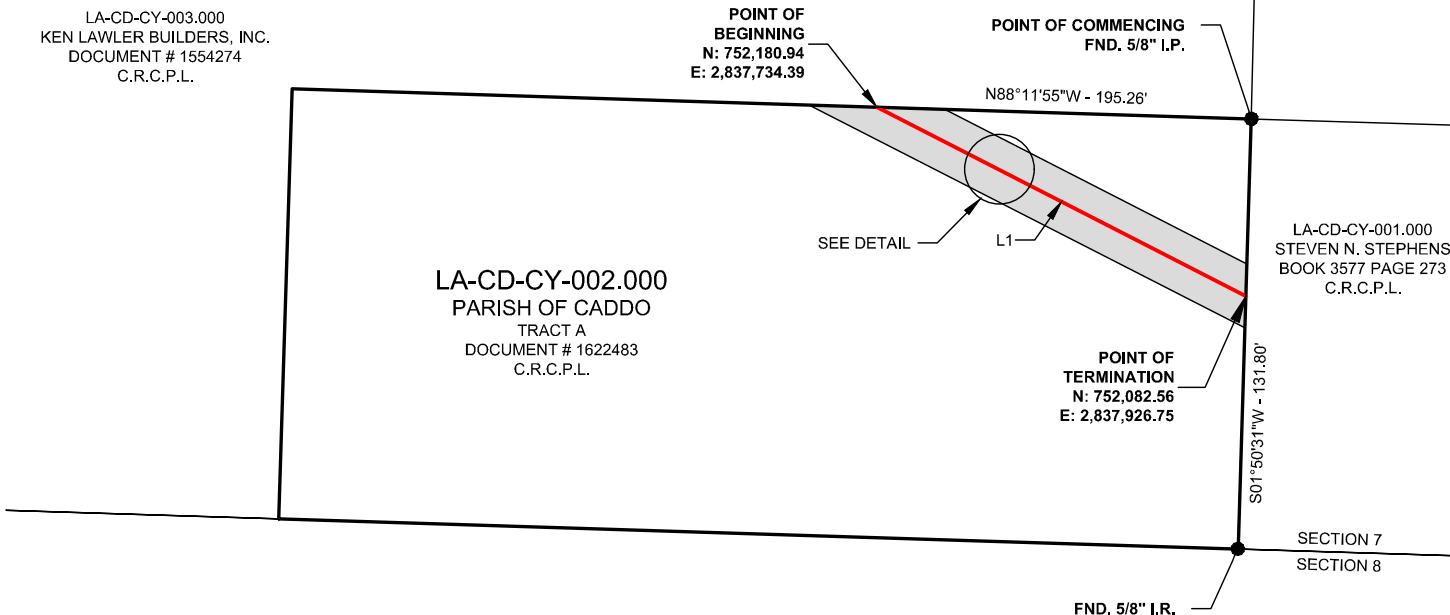
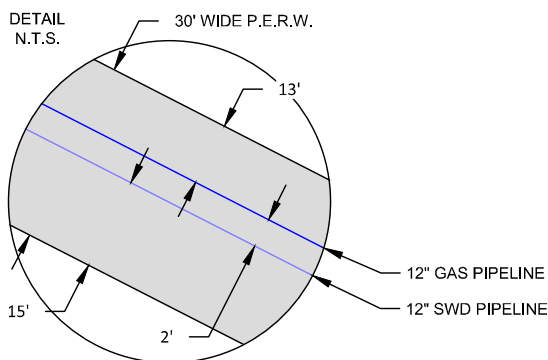

LA-CD-CY-002.000  
 PARISH OF CADDO  
 TRACT A  
 DOCUMENT # 1622483  
 C.R.C.P.L.

LA-CD-CY-001.000  
 STEVEN N. STEPHENS  
 BOOK 3577 PAGE 273  
 C.R.C.P.L.

Line Table		
Line #	Direction	Length
L1	S62° 54' 50"E	216.06

TOTAL AREA OF P.E.R.W.: 0.15 ACRES  
 TOTAL AREA OF T.W.S.: 0.00 ACRES  
 TOTAL AREA OF A.T.W.S.: 0.00 ACRES

TOTAL DISTANCE BASELINE ACROSS PROPERTY: 216.06 FEET  
 OR: 13.09 RODS  
 TOTAL DISTANCE PROPOSED 12" GAS PIPELINE ACROSS PROPERTY: 210.87 FEET  
 OR: 12.78 RODS  
 TOTAL DISTANCE PROPOSED 12" SWD PIPELINE ACROSS PROPERTY: 216.06 FEET  
 OR: 13.09 RODS

**LEGEND**

- I.R. IRON ROD
- I.P. IRON PIPE
- FND. FOUND
- N.T.S. NOT TO SCALE
- R-O-W RIGHT OF WAY
- C.R.C.P.L. CONVEYANCE RECORDS OF CADDO PARISH, LOUISIANA

- BROKEN LINE NOT SCALABLE
- PROPERTY LINE
- BASELINE
- R-O-W
- PERMANENT EASEMENT HATCH
- TEMPORARY WORKSPACE HATCH (T.W.S.)
- ADDITIONAL TEMPORARY WORKSPACE HATCH (A.T.W.S.)

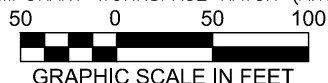

**NOTES**

- ALL BEARINGS, DISTANCES, AND COORDINATES SHOWN HEREIN ARE GRID, BASED UPON THE LOUISIANA COORDINATE SYSTEM, LOUISIANA NORTH ZONE, NORTH AMERICAN DATUM OF 1983 [NAD83(2011)(EPOCH:2010.0000)], U.S. SURVEY FEET, AS DERIVED FROM AN ON THE GROUND SURVEY PERFORMED BY ATWELL, LLC IN AUGUST 2021.
- THE TITLE INFORMATION OF THE SUBJECT TRACT, SHOWN HEREIN, IS BASED UPON TITLE RESEARCH CONDUCTED BY ENERGY ACCESS SOLUTIONS. THIS PLAT WAS PREPARED WITHOUT A COMMITMENT FOR TITLE INSURANCE. EASEMENTS OF RECORD MAY EXIST AND ARE NOT SHOWN HEREON. THIS PLAT DOES NOT REPRESENT A BOUNDARY SURVEY.
- FOR REFERENCE AND FURTHER INFORMATION, SEE ATTACHED LEGAL DESCRIPTION.

I, BRADLEY AMES DEMPSTER, PROFESSIONAL LAND SURVEYOR, HEREBY CERTIFY THIS SURVEY WAS PERFORMED UNDER MY DIRECT SUPERVISION AND IT SUBSTANTIALLY CONFORMS TO TITLE 46, PART LXI 2909 FOR ROUTE SURVEYS TO THE BEST OF MY KNOWLEDGE AND BELIEF.

**BRADLEY AMES DEMPSTER**  
 License No. 5212  
*Bradley Ames Dempster* 12/17/2021  
 BRADLEY AMES DEMPSTER  
 PROFESSIONAL LAND SURVEYOR  
 LOUISIANA REGISTRATION NO. 5212



NEXTERA		
DWG BY:	JCH	PROPOSED PIPELINE EASEMENT WITHIN THE PROPERTY OF PARISH OF CADDO
CKD BY:	BAD	
DATE:	10/29/21	
SCALE:	1"=100'	
REV#	DATE	DESCRIPTION
0	10/29/21	CERTIFIED
1	12/16/21	UPDATED FOOTPRINT
DRAWING:	21001030.02-LA-CD-CY-002.000	SHEET NO. 1 OF 2

EXHIBIT "B"

21001030.02  
LA-CD-CY-002.000  
Parish of Caddo

Permanent Easement and Right of Way

STATE OF LOUISIANA  
PARISH OF CADDO

P.E.R.W. CENTERLINE

Centerline description of thirty-foot (30') wide Permanent Easement and Right of Way situated in Section 7, Township 18 North, Range 15 West of the Louisiana Meridian, Caddo Parish, Louisiana and being over, through, and across a tract of land being described by an instrument to Parish of Caddo, recorded under Document # 1622483 of the Conveyance Records of Caddo Parish, Louisiana (C.R.C.P.L.) The sidelines of said thirty-foot (30') Permanent Easement and Right of Way being situated fifteen feet (15') on each side of the herein described baseline, with a proposed 12-inch (12") gas pipeline being offset 13 feet (13') south from the north sideline and a proposed 12-inch (12") saltwater disposal pipeline being situated 15 feet (15') north from the south sideline, said sidelines being lengthened or shortened to meet the boundary lines of said subject tract. (SEE EXHIBIT "A" FOR FURTHER CLARIFICATION). Said baseline being more particularly described as follow:

COMMENCING at a 5/8-inch iron pipe found for the northeast corner of said subject tract.

THENCE, North 88° 11' 55" West along the north line of said subject tract a distance of 195.26 feet to the POINT OF BEGINNING of the herein described baseline description. Said point of Beginning having coordinates of North: 752,180.94 and East: 2,837,734.39.

THENCE the following one (1) call:

- 1) South 62° 54' 50" East, a distance of 216.06 feet to the POINT OF TERMINATION on the east line of subject tract, having coordinates of North: 752,082.56 and East: 2,837,926.75, from which a 5/8-inch iron rod found for the southeast corner of said Subject tract, bears South 01° 50' 31" West, a distance of 131.80 feet on the south line of Section 7.

Said baseline being 216.06 Feet, or 13.09 Rods.  
Area of permanent easement and right-of-way being 0.15 acres.  
Length of said proposed 12" gas pipeline being 210.87 feet, or 12.78 rods.  
Length of said proposed 12" SWD pipeline being 216.06 feet, or 13.09 rods.

All Coordinates, bearings and distances shown herein are grid, based upon Louisiana Coordinate System, Louisiana North Zone, North American Datum of 1983, U.S. Survey Feet, as derived from an on the ground survey performed by Atwell, LLC conducted on August 2021.

For reference and further information see Exhibit "A" drawing number LA-CD-CY-002.000, Revision 1, same date.

BRADLEY AMES DEMPSTER  
License No. 5212  
12/17/2021

Bradley Ames Dempster  
Professional Land Surveyor  
Registration No. 5212  
Atwell, LLC  
VF # 0000755  
2 Towne Square, Suite 700  
Southfield, MI. 48076

**ORDINANCE FACT SHEET  
CADDO PARISH COMMISSION**

<b>TITLE</b>	Ordinance 6203 of 2022
	AN ORDINANCE TO AUTHORIZE THE ADMINISTRATOR TO EXECUTE AN EASEMENT AND RIGHT-OF-WAY AGREEMENT WITH CADDEAUX GATHERING, LLC REGARDING A PIPELINE THROUGH AND UNDER PARISH PROPERTY LOCATED IN SECTION 7, TOWNSHIP 18 NORTH, RANGE 15 WEST, CADDO PARISH, LOUISIANA,
<b>DATE:</b> February 10, 2022	<b>ORIGINATING DEPARTMENT:</b> Legal for Public Works
<b>BACKGROUND INFORMATION</b>	Caddeaux Gathering LLC has requested that the Parish grant it a pipeline servitude under a 2.5 acre tract of Parish property located just off Backpath Road south of Blanchard Furrh Road. The pipeline will be installed entirely by boring and not by open trenching such that the surface of the property will not be disturbed. The Parish property is not used for any purpose and is not adjacent to any other Parish property.
<b>FINANCIAL IMPACT AND SOURCE OF FUNDING</b>	No financial impact as the pipeline company will pay the Parish \$400 per rod for the servitude.
<b>EFFECT(S) OF PROPOSED ACTION</b>	Granting the servitude will provide the pipeline company with a means to install a pipeline. The restriction of not trenching will mean that the surface of the property will not be disturbed.
<b>ALTERNATIVES/STAFF RECOMMENDATION</b>	The alternative is to refuse to grant the servitude. Staff recommendation is to grant the servitude.
<b>KEY STAFF CONTACT</b>	Henry M Bernstein, Assistant Parish Attorney; Jimmy Whittington, Dept. of Public Works
<b>COORDINATION</b>	
Department Head	 (Initial) <b>NMB</b>
Parish Administrator/CEO	(Initial) <b>ak</b>

**RESOLUTION NO. 19 OF 2022**

BY THE CADDO PARISH COMMISSION:

A RESOLUTION AMENDING THE RULES AND BY-LAWS OF THE CADDO PARISH COMMISSION REGARDING THE RE-SUBMISSION OF AGENDA ITEMS BY COMMISSIONERS, AND OTHERWISE PROVIDING WITH RESPECT THERETO.

WHEREAS, it has come to the attention of the Caddo Parish Commission that several resolutions presented by parish commissioners for the body's consideration are re-submitted for consideration numerous times; and

WHEREAS, numerous re-submissions to the body causes inefficiency and unnecessary lengthiness of regular meetings and work sessions;

NOW, THEREFORE, BE IT ORDAINED by the Caddo Parish Commission in due, regular and legal session convened, that Article V of the Caddo Parish Commission Bylaws be amended and reenacted to read as follows to-wit:

**ARTICLE V**

Rights and Duties of the Commission

RULE 2: When the Commission shall be equally divided on any question, including the President's vote, the question shall be deemed lost.

RULE 2.1: When any question on a resolution or ordinance is deemed lost, the ordinance or resolution shall not be placed on the agenda, in any form, within thirty (30) days from the date the question was lost.

BE IT FURTHER RESOLVED that if any provision or item of this resolution or the application thereof is held invalid, such invalidity shall not affect other provisions, items or applications which can be given effect without the invalid provisions, items or applications, and to this end, the provisions of this resolution are hereby declared severable.

BE IT FURTHER RESOLVED that this resolution shall take effect immediately.

BE IT FURTHER RESOLVED that all resolutions or parts thereof in conflict herewith are hereby repealed.

Approved as to legal form:

\_\_\_\_\_  
Parish Attorney

\_\_\_\_\_  
Date

**ORDINANCE AND RESOLUTION FACT SHEET**

**CADDO PARISH COMMISSION**

<b>TITLE</b>	
<b>RESOLUTION 19 OF 2022</b>  A RESOLUTION AMENDING THE RULES AND BY-LAWS OF THE CADDO PARISH COMMISSION REGARDING THE RE-SUBMISSION OF AGENDA ITEMS BY COMMISSIONERS, AND OTHERWISE PROVIDING WITH RESPECT THERETO.	
DATE 2/14/2021	ORIGINATING DEPARTMENT: Legal for Commissioner Chavez
<b>BACKGROUND INFORMATION</b>	
This amendment would provide for a period of time before failed legislation could be re-introduced.	
<b>FINANCIAL IMPACT AND SOURCE OF FUNDING</b>	
None	
<b>EFFECT(S) OF PROPOSED ACTION</b>	
See background information above.	
<b>ALTERNATIVES/STAFF RECOMMENDATION</b>	
Do not pass resolution; staff has no recommendation.	
<b>KEY STAFF CONTACT</b>	
Donna Frazier, Parish Attorney	
<b>COORDINATION</b>	
Department Head	(Initial) <i>dyz</i>
Parish Attorney	(Initial) <i>dyz</i>
Parish Administrator/CEO	(Initial) <i>df</i>

## **RESOLUTION No. 20 of 2022**

### **BY THE CADDO PARISH COMMISSION**

A RESOLUTION CONFIRMING PARTICIPATION IN THE LOUISIANA COMMUNITY DEVELOPMENT BLOCK GRANT FISCAL YEAR 2022 PUBLIC FACILITY IMPROVEMENT PROJECT WITH WATERWORKS DISTRICT NO. 7, IDENTIFYING PARTNERS AND OTHERWISE PROVIDING WITH RESPECT THERETO

WHEREAS, the Caddo Parish Commission is submitting an application for a FY 2022 Louisiana Community Development Block Grant (LCDBG) for public facility improvements; and

WHEREAS, the Caddo Parish Commission has entered into contracts with The Coordinating & Development Corporation for administrative services and CGS Engineering, Inc. for engineering services, and agree all administrative services/engineering costs will be paid by the Caddo Parish Commission and Waterworks District No. 7; and

WHEREAS, the Board of Directors of Waterworks District No.7 has passed a resolution stating that if grant funds are made available for the public facility improvement project, the Board will contribute 10% of the total project funds up to \$100,000 to construction and design of the project (engineering fees); and

WHEREAS, the Caddo Parish Commission will pay The Coordinating & Development Corporation an amount of \$36,400 for LCDBG pre-agreement and administrative services. CGS Engineering, Inc. proposed contract amount is \$116,000, and the Board of Directors of Waterworks District No. 7 will contribute \$100,000, and the Caddo Commission will pay the remaining \$16,000 for the engineering services; and

WHEREAS, the Caddo Parish Commission will receive 2 bonus points for their monetary contributions for paying engineering costs.

NOW THEREFORE BE IT RESOLVED, the Commission President and Parish Commission of Caddo Parish, Louisiana, do hereby agree to pay for the aforementioned engineering and administration fees associated with the implementation of the LCDBG programs out of local funds.

## C E R T I F I C A T E

I, Jeff Everson, Commission Clerk, hereby certify that the above constitutes a true and accurate copy of a Resolution, which UPON MOTION of \_\_\_\_\_, and seconded by \_\_\_\_\_, was adopted by the following Yea and Nay vote:

YEA:

NAY:

ABSENT:

and the same was declared adopted by the Commission President this \_\_\_\_\_ day of \_\_\_\_\_, 2022.

---

Jeff Everson, Commission Clerk  
Caddo Parish, Louisiana

**ORDINANCE NO. 6191 OF 2022**

BY THE CADDO PARISH COMMISSION:

**AN ORDINANCE AMENDING THE BUDGET OF ESTIMATED REVENUES AND EXPENDITURES FOR THE RIVERBOAT FUND AND OIL AND GAS FUND IN THE AMOUNT OF \$10,000 TO PROVIDE AN APPROPRIATION FOR THE LOUISIANA ADVOCATES FOR IMMIGRANTS IN DETENTION ASSOCIATED WITH THE HIGHLAND CENTER AND TO OTHERWISE PROVIDE WITH RESPECT THERETO**

WHEREAS, the Highland Center works with Louisiana Advocates for Immigrants in Detention (LA-AID); and

WHEREAS, LA-AID is an organization of volunteers who became active in the fall of 2019 in response to the burgeoning population of asylum seekers being held in Immigration and Customs Enforcement detention centers in rural Louisiana; and

WHEREAS, in the past 5 years, Louisiana went from having 1 immigration detention center to having 8 large detention centers ; and

WHEREAS, the Shreveport-based chapter of LA-AID, the only non-profit in Louisiana supporting post-release assistance, has been actively rescuing individuals who need safe transportation assistance from these facilities since February 2021; and

WHEREAS, the work of the LA-AID has been coordinated out of an expanded office affiliated with the Church for the Highlands where immigrants can cook meals, wash clothing, shower, use Internet and mobile phones, print boarding passes, and rest comfortably; and

WHEREAS, LA-AID is led by two unpaid, full-time volunteers and many additional volunteers from church congregations across Caddo Parish; and

WHEREAS, the Caddo Parish Commission would like to amend the 2022 Riverboat Fund and Oil and Gas Fund Budgets to provide an appropriation of \$10,000 for LA-AID; and

NOW, THEREFORE, BE IT ORDAINED, by the Caddo Parish Commission in due, legal and regular session convened, that Budget of Estimated Revenues and Expenditures for the Riverboat Fund and Oil and Gas Fund for the year 2022 is hereby amended as follows:

	<u>Budget Increase (Decrease)</u>
<b><u>Riverboat Fund</u></b>	
NGO Appropriations	
LA-AID	\$10,000
Transfer from Oil and Gas Fund	\$10,000
<b><u>Oil and Gas Fund</u></b>	
Transfer to Riverboat Fund	\$10,000
Fund Balance	(\$10,000)

BE IT FURTHER ORDAINED, that if any provision or item of this ordinance or the application thereof is held invalid, such invalidity shall not affect other provisions, items or applications which can be given effect without the invalid provisions, items or applications, and to this end the provisions of this ordinance are hereby declared severable.

BE IT FURTHER ORDAINED, that this ordinance shall take effect upon adoption.

BE IT FURTHER ORDAINED, that all ordinances or parts thereof in conflict herewith are hereby repealed.

Approved as to legal form:

\_\_\_\_\_  
Parish Attorney

\_\_\_\_\_  
Date

**ORDINANCE AND RESOLUTION AUTHORIZATION FORM**

**CADDO PARISH COMMISSION**

**TITLE**

ORDINANCE AMENDING THE 2022 BUDGET OF ESTIMATED REVENUES AND EXPENDITURES FOR THE RIVERBOAT FUND AND OIL AND GAS FUND

**(Ordinance No. 6191 of 2022)**

**ORIGINATING DEPARTMENT: Commissioner John Paul Young**

**BACKGROUND INFORMATION:** Amending the budget of Estimated Revenues and Expenditures for the Riverboat and Oil and Gas Fund to provide an appropriation of \$10,000 for LA-AID.

**Background and Capacity of Organization**

Louisiana Advocates for Immigrants in Detention (LA-AID) is an organization of volunteers who became active in the fall of 2019 in response to the burgeoning population of asylum seekers being held in Immigration and Customs Enforcement detention centers in rural Louisiana. In the past 5 years, Louisiana went from having 1 immigration detention center to having 8 large detention centers.

Nearly all the people transported to Louisiana by the federal government are healthy adults, affirmed to remain in the United States because of a credible fear of persecution or torture. Each person has been approved to continue his or her case in the court system while living with a sponsor (a family member or friend), who is a U.S. citizen or legal permanent resident.

With 16 partner organizations, LA-AID has filed a federal administrative complaint that the privately-owned detention facilities in Louisiana, who contract with ICE, have been releasing immigrants against federal agency policy into remote areas and in unsafe conditions without resources to contact their families or arrange customary transportation.

Detention facilities are required to provide immigrants in their care with free and safe transportation to the nearest public transport center (national bus station or airport) and allow each person to talk with their sponsor to make travel arrangements. However, it is well documented that these policies are not being followed in Louisiana and privately-owned facilities are in violation of ICE's Performance-Based National Detention Standards (PBNDS), established in 2011.

**Prior Experience of Organization, Joint Group Application and Collaboration, & Identify Needs and Gaps in Services in Neighborhood**

There are 3 detention centers within a 3-hour drive of Shreveport: Jena/LaSalle Detention Facility in Jena, LA; Winn Correctional Center in Winnfield, LA; and Jackson Parish Correctional Center in Jonesboro, LA. The Shreveport-based chapter of LA-AID has been actively rescuing individuals who need safe transportation assistance from these facilities since February 2021. While there are

many established, emergency-support immigration NGOs in “border states” such as Texas and Arizona, Louisiana does not have any similar nonprofits supporting similar post-release assistance.

Therefore, our volunteers receive notice each day if individuals will be released that same day in rural Louisiana and drive 4-6 hours round-trip to pick up the guest so that each immigrant will have safe transportation and accommodations as they travel through the nearest regional transportation hubs found in Caddo Parish.

Our volunteer-led organization purchases pre-paid phones so that guests can call their families and book travel arrangements. Volunteers provide translation services, assist with flights or bus tickets, and ensure that each person eats and has a safe place to spend a night. Volunteers drive guests to the airport each day before their flights and walk them to a TSA Agent.

**Extent of Neighborhood Involvement & Description of Project and Soundness of Project**

This work has been coordinated out of an expanded office affiliated with the Church for the Highlands where guests can cook meals, wash clothing, shower, use Internet and mobile phones, print boarding passes, and rest comfortably. The new nonprofit is led by two unpaid, full-time volunteers and many additional volunteers from church congregations across Caddo Parish. The team is also actively coordinating with their counterparts in other Louisiana cities.

Over 436 immigrants traveled through Caddo Parish between March and July 2021 and were assisted by LA-AID. Between July – December 2021, our volunteers drove 16,378 miles and helped 798 people from over 46 countries reunite with family and friends around the United States as they safely traveled through Caddo Parish.

While we are glad to help guests in need unite their families safely, hosting new and unexpected guests for weeks and weeks has also pushed the limits of our professional capacity and the generosity of our hosts. Support from the Parish of Caddo would help ensure that our organization is able to continue operating and meet the public safety crisis that has emerged in our region.

**KEY STAFF CONTACT:** Hayley Barnett

**AUTHORIZATION**

Department Head Hayley Barnett Date 1/26/2022

Legal \_\_\_\_\_ Date \_\_\_\_\_

Parish Administrator \_\_\_\_\_ Date \_\_\_\_\_



*PARISH OF CADDO, LOUISIANA*

*GUIDELINES FOR APPROPRIATION APPLICATIONS*

Name of Entity: Louisiana Advocates for Immigrants in Detention (LA-AID)

**Please review the following guidelines for funding and initial indicating you have read and understand each item prior to submitting an application:**

- FK 1. Appropriations are made on an annual basis; **receiving funding one year does not guarantee that the organization will receive funds in the same amount, or at all during the next year.**
- FK 2. Funds are appropriated for specific programs that an organization sponsors and **cannot be used for the day-to-day operating expenses of the organization (i.e. salaries, office expenses, rent).**
- FK 3. The program for which an appropriation is requested must provide services to unskilled poor, low-income persons, unemployed persons or students from those families; alternatively, the program must provide a measurable means of economic development for Caddo Parish.
- FK 4. Funds cannot be used for the following:
  - a. Capital purchases/improvements such as building repairs/renovations, playground equipment (even if for the parish-funded program) of an organization;
  - b. Equipment used in any other program other than the one the Parish is funding;
  - c. To benefit non-Caddo citizens.
- FK 5. Funds cannot be used directly or indirectly in any trade or business carried on by any person or entity other than Grantee.
- FK 6. An organization receiving monies through the Caddo Parish Commission's appropriation process must give two reports detailing the use of those funds: a report detailing the use of the funds from January 1<sup>st</sup> - June 30<sup>th</sup> of the appropriation year (due July 31<sup>st</sup>), and a report detailing the use of the funds from July 1<sup>st</sup> - December 31<sup>st</sup> of the appropriation year (due January 31<sup>st</sup> of the year following the appropriation). A subsequent appropriation application will **not** be considered if the July 31<sup>st</sup> report has not been timely submitted; an approved appropriation will **not** be funded if the January 31<sup>st</sup> report has not been timely submitted. These reports must include invoices, receipts cancelled checks and any other documents related to the expenditure of Parish funds, and the Parish reserves the right to audit all organization records related to the appropriation at any time.
- FK 7. No funds will be paid until all required reports have been received and approved by the Parish of Caddo.
- FK 8. Funds must be spent **in accordance with the provisions outlined in the Cooperative Endeavor Agreement (CEA)**. Listing items in the detailed budget does not make them eligible for reimbursement; the items must be covered in the CEA.

**SECTION I: INTRODUCTION AND FUNDING PURPOSE**

It is important that each section of this request be completed.

1. **Name of Entity:** Louisiana Advocates for Immigrants in Detention

**Commission District:** District 4

**Address:** 520 Olive Street

Shreveport, LA 71104

**Is this the address of the organization's headquarters?**  Yes  No

*If not, please list headquarter address:* \_\_\_\_\_

**Does your organization provide services in more than one commission district?**

Yes  No

*If yes please list other districts served and addresses (if available):*

**District** \_\_\_\_\_

**District** \_\_\_\_\_

**Address** \_\_\_\_\_

**Address** \_\_\_\_\_

**Contact Person:** Mr. / Mrs. / Ms. Frances Kelley

**Title:** Board Secretary

**Phone Number:** ( 318 ) 780-4138

**Fax:** ( \_\_\_\_\_ ) \_\_\_\_\_

**Email:** frances.elizabeth.kelley@gmail.com

**Past Grant Recipient?**  Yes  No

2. **Purpose for which Parish funds would be used (Check one and give brief description):**

**Economic Development:**

**Education:**

**Social Welfare:**

Abate public safety and humanitarian crisis related to illegal implementation of federal laws on immigration impacting Caddo Parish

3. **Amount of this funding request:** \$10,000

4. **During what time period will the funds be used:** Jan. 1, 2022 through December 30, 2022

5. Are audited financial statements available?  Yes  No

Please furnish most recent financial statement period covered:

July 1, 2021 through December 30, 2021

6. Are you exempt from Federal Income Tax?  Yes  No

Under IRS Code Section: 501(c)(3)

7. Have you filed form 990 (Return of Organization Exempt from Income Tax)?  Yes  No

Date of last time filed: \_\_\_\_\_

8. Quarterly drawdowns are agreed to be acceptable:  Yes  No  
*(If not, please propose an alternate drawdown schedule and explain)*

9. Does the organization have any outstanding tax claims (City, Parish, State or Federal)?  
 Yes  No *(If so, please explain claim)*

10. Are you in good standing with the State of Louisiana?  Yes  No  
Please provide a copy of your Certificate of Good Standing.

N/A

11. Please attach any other information that you wish to submit in support of your application.

## **SECTION II: PROPOSAL NARRATIVE**

The proposal narrative must be formatted as outlined below. Proposals that are not submitted in the following format will not be reviewed. This section shall not exceed three pages, double spaced in 12-font. The application outline must address all of the following items below:

### **Background and Capacity of Organization**

Briefly describe your organization. This description should include the length of existence, the number of officers, members, and mission. Explain the organization's capacity to successfully implement the proposed project in a timely manner.

### **Prior Experience of Organization**

Description of past completed projects involving community and Parish activities in the past three (3) years, including the type of project, project location, and how it benefited the Parish.

### **Extent of Neighborhood Involvement**

Describe the manner in which you will attract volunteers to your project. Describe how a significant number of people with diverse interests in the neighborhood will be involved in and benefit from this project.

### **Description of Project and Soundness of Project**

This summary should provide an overview of entire project(s), including project location and how this project will benefit the Parish. This project must be clearly understood, well planned, and ready to proceed.

### **Joint Group Application and Collaboration**

State whether your organization is submitting this application along with another Parish-based organization. Also, describe any partnerships that were formed or will be formed to plan and implement this project. Please include names of all partnerships, consultants and other organizations that Caddo Parish appropriations will fund with the amount of monies going to each.

### **Identify Needs and Gaps in Services in Neighborhood**

List the priority needs that the organization has identified in the neighborhood along with any gaps of services that have been noted.

## **Background and Capacity of Organization**

Louisiana Advocates for Immigrants in Detention (LA-AID) is an organization of volunteers who became active in the fall of 2019 in response to the burgeoning population of asylum seekers being held in Immigration and Customs Enforcement detention centers in rural Louisiana. In the past 5 years, Louisiana went from having 1 immigration detention center to having 8 large detention centers.

Many people transported to Louisiana by the federal government are adults, affirmed to remain in the United States because of a credible fear of persecution or torture. Each person has been approved to continue his or her case in the court system while living with a U.S. sponsor (a family member or friend).

With 16 partner organizations, LA-AID has filed a federal administrative complaint that the privately-owned detention facilities in Louisiana, who contract with ICE, have been releasing immigrants against federal agency policy into remote areas and in unsafe conditions without resources to contact their families or arrange customary transportation.

Detention facilities are required to provide immigrants in their care with free and safe transportation to the nearest public transport center (national bus station or airport) and allow each person to talk with their sponsor to make travel arrangements. However, it is well documented that these policies are not being followed in Louisiana and privately-owned facilities are in violation of ICE's Performance-Based National Detention Standards (PBNDS), established in 2011.

## **Prior Experience of Organization, Joint Group Application and Collaboration, & Identify Needs and Gaps in Services in Neighborhood**

There are 3 detention centers within a 3-hour drive of Shreveport: Jena/LaSalle Detention Facility in Jena, LA; Winn Correctional Center in Winnfield, LA; and Jackson Parish Correctional Center in Jonesboro, LA. The Shreveport-based chapter of LA-AID has been actively assisting individuals who need safe transportation from these facilities since February 2021. While there are many established, emergency-support immigration NGOs in "border states" such as Texas and Arizona, Louisiana does not have any similar nonprofits supporting similar post-release assistance.

Therefore, our volunteers receive notice each day if individuals will be released that same day in rural Louisiana and drive 4-6 hours round-trip to pick up the guest so that each immigrant will have safe transportation and accommodations as they travel through the regional transportation hubs found in Caddo Parish.

Our volunteer-led organization purchases pre-paid phones so that guests can call their families and book travel arrangements. Volunteers provide translation services, assist with flights or bus tickets, and ensure that each person eats and has a safe place to spend a night. Volunteers drive guests to the airport each day before their flights and walk them to a TSA Agent.

## **Extent of Neighborhood Involvement & Description of Project and Soundness of Project**

This work has been coordinated out of an expanded office affiliated with the Church for the Highlands where guests can cook meals, wash clothing, shower, use Internet and mobile phones, print boarding passes, and rest comfortably. The new nonprofit is led by two unpaid, full-time volunteers and many additional volunteers from church congregations across Caddo Parish. The team is also actively coordinating with their counterparts in other Louisiana cities.

Over 436 immigrants traveled through Caddo Parish between March and July 2021 and were assisted by LA-AID. Between July – December 2021, our volunteers drove 16,378 miles and helped 798 people from over 46 countries reunite with family and friends around the United States as they safely traveled through Caddo Parish.

While we are glad to help guests in need unite their families safely, hosting new and unexpected guests for weeks and weeks has also pushed the limits of our professional capacity and the generosity of our hosts. Support from the Parish of Caddo would help ensure that our organization is able to continue operating and meet the public safety crisis that has emerged in our region.

## ATTACHMENT A: CONTACT INFORMATION

List the names, addresses, and Commission District (if applicable) of all board members.

Name	Address	Commission District
Frances Kelley	935 Linden Street Shreveport, LA 71104	4
Michelle LaFleur MacFadyen	107 Silverbell Parkway Lafayette, LA 70508	NA
Leslie Elliottsmith	6006 Navaho Trail Alexandria, LA 71301	NA

## ATTACHMENT B: PROJECT TIMELINE

**This summary should provide a written timeline to show benchmarks for project implementation and completion. Describe any recent, relevant and successfully demonstrated experience in undertaking similar projects. Include the knowledge and experience of the proposed day-to-day project team leader.**

Building on the past year of effective work, from January 1, 2022, to June 30, 2022, the Caddo-based chapter of the nonprofit LA-AID will ensure that asylum seekers- who are approved to travel through Caddo Parish from the nearest three Immigrant and Customs Enforcement detention centers to their families and friends across the United States- will have safe and professional assistance with translation, transportation, and essential needs as the federal agency improves their processes and the state-wide agency builds capacity to accommodate and support this new, regional humanitarian and public safety crisis.

**ATTACHMENT C:**

**Caddo Parish Appropriation BUDGET FORM**

Please provide detailed explanation of each line item.

Organization Name \_\_\_\_\_

LA-AID \_\_\_\_\_

Budget Year 2022

**Funding Amount**

<b>Line Item Object</b>	<b>Parish Amount</b>	<b>Other Amounts*</b>	<b>In-Kind (Including Food Bank)</b>	<b>Total</b>
Facility		\$20,790.00		\$20,790.00
Personnel			\$55,000.00	\$55,000.00
Mileage		\$2,100.00		\$2,100.00
Meals	\$5,494.00	\$2,640.00		\$8,170.00
Telecommunications	\$1,400.00	\$676.00		\$2,076.00
Supplies	\$920.00		\$2,280.00	\$3,200.00
Repairs	\$1,750.00	\$1,850.00		\$3,600.00
Airport Parking		\$540.00		\$540.00
Insurance	\$436.00	\$514.00		\$950.00
<b>Total</b>	\$10,000.00	\$29,110.00	\$57,280.00	\$96,426.00

\*Please provide a detailed listing of the funding source for other amounts.

\*If funding tuition for low-income persons to attend your program, please provide a detailed listing of the items covered by the tuition.



Department of the Treasury  
Internal Revenue Service  
Tax Exempt and Government Entities  
P.O. Box 2508  
Cincinnati, OH 45201

LOUISIANA ADVOCATES FOR  
IMMIGRANTS IN DETENTION  
262 WILKINSON STREET  
SHREVEPORT, LA 71104

**Date:**  
01/07/2022  
**Employer ID number:**  
87-2935596  
**Person to contact:**  
Name: Customer Service  
ID number: 31954  
Telephone: (877) 829-5500  
**Accounting period ending:**  
December 31  
**Public charity status:**  
170(b)(1)(A)(vi)  
**Form 990 / 990-EZ / 990-N required:**  
Yes  
**Effective date of exemption:**  
September 28, 2021  
**Contribution deductibility:**  
Yes  
**Addendum applies:**  
No  
**DLN:**  
26053691002261

Dear Applicant:

We're pleased to tell you we determined you're exempt from federal income tax under Internal Revenue Code (IRC) Section 501(c)(3). Donors can deduct contributions they make to you under IRC Section 170. You're also qualified to receive tax deductible bequests, devises, transfers or gifts under Section 2055, 2106, or 2522. This letter could help resolve questions on your exempt status. Please keep it for your records.

Organizations exempt under IRC Section 501(c)(3) are further classified as either public charities or private foundations. We determined you're a public charity under the IRC Section listed at the top of this letter.

If we indicated at the top of this letter that you're required to file Form 990/990-EZ/990-N, our records show you're required to file an annual information return (Form 990 or Form 990-EZ) or electronic notice (Form 990-N, the e-Postcard). If you don't file a required return or notice for three consecutive years, your exempt status will be automatically revoked.

If we indicated at the top of this letter that an addendum applies, the enclosed addendum is an integral part of this letter.

For important information about your responsibilities as a tax-exempt organization, go to [www.irs.gov/charities](http://www.irs.gov/charities). Enter "4221-PC" in the search bar to view Publication 4221-PC, Compliance Guide for 501(c)(3) Public Charities, which describes your recordkeeping, reporting, and disclosure requirements.

Sincerely,

Stephen A. Martin  
Director, Exempt Organizations  
Rulings and Agreements

**AFFIDAVIT**

I hereby certify that the information provided in this application and all accompanying forms is true and accurate as of the date of completion.

**Signature:**

Frances Kelley

**Title:**

Board Secretary

**Date:**

1/26/22



**SECRETARY  
OF STATE**  
B. GUYLE ARMBRIST

(https://www.sos.la.gov/Pages/default.aspx)

**Search for Louisiana Business Filings**

[Buy Certificates and Certified Copies](#) [Subscribe to Electronic Notification](#) [Print Detailed Record](#)

<b>Name</b>	<b>Type</b>	<b>City</b>	<b>Status</b>
LOUISIANA ADVOCATES FOR IMMIGRANTS IN DETENTION	Non-Profit Corporation	SHREVEPORT	Active

**Previous Names**

**Business:** LOUISIANA ADVOCATES FOR IMMIGRANTS IN DETENTION  
**Charter Number:** 44613657N  
**Registration Date:** 10/1/2021

**Domicile Address**

262 WILKINSON STREET  
 SHREVEPORT, LA 71104

**Mailing Address**

262 WILKINSON STREET  
 SHREVEPORT, LA 71104

**Status**

**Status:** Active  
**Annual Report Status:** In Good Standing  
**File Date:** 10/1/2021  
**Last Report Filed:** N/A  
**Type:** Non-Profit Corporation

**Registered Agent(s)**

<b>Agent:</b>	MADISON POCHE
<b>Address 1:</b>	262 WILKINSON STREET
<b>City, State, Zip:</b>	SHREVEPORT, LA 71104
<b>Appointment Date:</b>	10/1/2021

**Officer(s)**

Additional Officers: No

<b>Officer:</b>	FRANCES KELLEY
<b>Title:</b>	Director
<b>Address 1:</b>	935 LINDEN STREET
<b>City, State, Zip:</b>	SHREVEPORT, LA 71104
<b>Officer:</b>	MICHELLE LAFLEUR MACFADYEN
<b>Title:</b>	Director
<b>Address 1:</b>	107 SILVERBELL PARKWAY
<b>City, State, Zip:</b>	LAFAYETTE, LA 70508
<b>Officer:</b>	LESLIE ELLIOTTSMITH
<b>Title:</b>	Director
<b>Address 1:</b>	6006 NAVAHO TRAIL
<b>City, State, Zip:</b>	ALEXANDRIA, LA 71301

**Amendments on File**

No Amendments on file

[Back to Search Results](#) [New Search](#) [View Shopping Cart](#)

GET HELP

# PARISH OF CADDO, LOUISIANA

## GUIDELINES FOR APPROPRIATION APPLICATIONS

Name of Entity: Louisiana Advocates for Immigrants in Detention (LA-AID)

**Please review the following guidelines for funding and initial indicating you have read and understand each item prior to submitting an application:**

- FK 1. Appropriations are made on an annual basis; **receiving funding one year does not guarantee that the organization will receive funds in the same amount, or at all during the next year.**
- FK 2. Funds are appropriated for specific programs that an organization sponsors and **cannot be used for the day-to-day operating expenses of the organization (i.e. salaries, office expenses, rent).**
- FK 3. The program for which an appropriation is requested must provide services to unskilled poor, low-income persons, unemployed persons or students from those families; alternatively, the program must provide a measurable means of economic development for Caddo Parish.
- FK 4. Funds cannot be used for the following:
  - a. Capital purchases/improvements such as building repairs/renovations, playground equipment (even if for the parish-funded program) of an organization;
  - b. Equipment used in any other program other than the one the Parish is funding;
  - c. To benefit non-Caddo citizens.
- FK 5. Funds cannot be used directly or indirectly in any trade or business carried on by any person or entity other than Grantee.
- FK 6. An organization receiving monies through the Caddo Parish Commission's appropriation process must give two reports detailing the use of those funds: a report detailing the use of the funds from January 1<sup>st</sup> - June 30<sup>th</sup> of the appropriation year (due July 31<sup>st</sup>), and a report detailing the use of the funds from July 1<sup>st</sup> - December 31<sup>st</sup> of the appropriation year (due January 31<sup>st</sup> of the year following the appropriation). A subsequent appropriation application will **not** be considered if the July 31<sup>st</sup> report has not been timely submitted; an approved appropriation will **not** be funded if the January 31<sup>st</sup> report has not been timely submitted. These reports must include invoices, receipts cancelled checks and any other documents related to the expenditure of Parish funds, and the Parish reserves the right to audit all organization records related to the appropriation at any time.
- FK 7. No funds will be paid until all required reports have been received and approved by the Parish of Caddo.
- FK 8. Funds must be spent **in accordance with the provisions outlined in the Cooperative Endeavor Agreement (CEA)**. Listing items in the detailed budget does not make them eligible for reimbursement; the items must be covered in the CEA.

# SECTION I: INTRODUCTION AND FUNDING PURPOSE

It is important that each section of this request be completed.

1. Name of Entity: Louisiana Advocates for Immigrants in Detention

Commission District: District 4

Address: 520 Olive Street

Shreveport, LA 71104

Is this the address of the organization's headquarters?  Yes  No

If not, please list headquarter address: \_\_\_\_\_

Does your organization provide services in more than one commission district?

Yes  No

If yes please list other districts served and addresses (if available):

District \_\_\_\_\_

District \_\_\_\_\_

Address \_\_\_\_\_

Address \_\_\_\_\_

Contact Person: Mr. / Mrs. / Ms. Frances Kelley

Title: Board Secretary

Phone Number: ( 318 ) 780-4138

Fax: ( \_\_\_\_\_ ) \_\_\_\_\_

Email: frances.elizabeth.kelley@gmail.com

Past Grant Recipient?  Yes  No

2. Purpose for which Parish funds would be used (Check one and give brief description):

Economic Development:

Education:

Social Welfare:

Abate public safety and humanitarian crisis related to illegal implementation of federal laws on immigration impacting Caddo Parish

3. Amount of this funding request: \$10,000

4. During what time period will the funds be used: Jan. 1, 2022 through December 30, 2022

5. Are audited financial statements available?  Yes  No

Please furnish most recent financial statement period covered:

July 1, 2021 through December 30, 2021

6. Are you exempt from Federal Income Tax?  Yes  No

Under IRS Code Section: 501(c)(3)

7. Have you filed form 990 (Return of Organization Exempt from Income Tax)?  Yes  No

Date of last time filed: \_\_\_\_\_

8. Quarterly drawdowns are agreed to be acceptable:  Yes  No

*(If not, please propose an alternate drawdown schedule and explain)*

9. Does the organization have any outstanding tax claims (City, Parish, State or Federal)?

Yes  No *(If so, please explain claim)*

10. Are you in good standing with the State of Louisiana?  Yes  No

Please provide a copy of your Certificate of Good Standing.

N/A

11. Please attach any other information that you wish to submit in support of your application.

## SECTION II: PROPOSAL NARRATIVE

The proposal narrative must be formatted as outlined below. Proposals that are not submitted in the following format will not be reviewed. This section shall not exceed three pages, double spaced in 12-font. The application outline must address all of the following items below:

### **Background and Capacity of Organization**

Briefly describe your organization. This description should include the length of existence, the number of officers, members, and mission. Explain the organization's capacity to successfully implement the proposed project in a timely manner.

### **Prior Experience of Organization**

Description of past completed projects involving community and Parish activities in the past three (3) years, including the type of project, project location, and how it benefited the Parish.

### **Extent of Neighborhood Involvement**

Describe the manner in which you will attract volunteers to your project. Describe how a significant number of people with diverse interests in the neighborhood will be involved in and benefit from this project.

### **Description of Project and Soundness of Project**

This summary should provide an overview of entire project(s), including project location and how this project will benefit the Parish. This project must be clearly understood, well planned, and ready to proceed.

### **Joint Group Application and Collaboration**

State whether your organization is submitting this application along with another Parish-based organization. Also, describe any partnerships that were formed or will be formed to plan and implement this project. Please include names of all partnerships, consultants and other organizations that Caddo Parish appropriations will fund with the amount of monies going to each.

### **Identify Needs and Gaps in Services in Neighborhood**

List the priority needs that the organization has identified in the neighborhood along with any gaps of services that have been noted.



## ATTACHMENT B: PROJECT TIMELINE

**This summary should provide a written timeline to show benchmarks for project implementation and completion. Describe any recent, relevant and successfully demonstrated experience in undertaking similar projects. Include the knowledge and experience of the proposed day-to-day project team leader.**

Building on the past year of effective work, from January 1, 2022, to June 30, 2022, the Caddo-based chapter of the nonprofit LA-AID will ensure that asylum seekers- who are approved to travel through Caddo Parish from the nearest three Immigrant and Customs Enforcement detention centers to their families and friends across the United States- will have safe and professional assistance with translation, transportation, and essential needs as the federal agency improves their processes and the state-wide agency builds capacity to accommodate and support this new, regional humanitarian and public safety crisis.

**ATTACHMENT C:**  
**Caddo Parish Appropriation BUDGET FORM**  
Please provide detailed explanation of each line item.

Organization Name LA-AID

Budget Year 2022

Line Item Object	Funding Amount			Total
	Parish Amount	Other Amounts*	In-Kind (Including Food Bank)	
Facility		\$20,790.00		\$20,790.00
Personnel			\$55,000.00	\$55,000.00
Mileage		\$2,100.00		\$2,100.00
Meals	\$5,494.00	\$2,640.00		\$8,170.00
Telecommunications	\$1,400.00	\$676.00		\$2,076.00
Supplies	\$920.00		\$2,280.00	\$3,200.00
Repairs	\$1,750.00	\$1,850.00		\$3,600.00
Airport Parking		\$540.00		\$540.00
Insurance	\$436.00	\$514.00		\$950.00
<b>Total</b>	\$10,000.00	\$29,110.00	\$57,280.00	\$96,426.00

\*Please provide a detailed listing of the funding source for other amounts.

\*If funding tuition for low-income persons to attend your program, please provide a detailed listing of the items covered by the tuition.

**AFFIDAVIT**

**I hereby certify that the information provided in this application and all accompanying forms is true and accurate as of the date of completion.**

**Signature:**

\_\_\_\_\_

**Title:**

\_\_\_\_\_

**Date:**

\_\_\_\_\_

## CHECKLIST OF REQUIRED DOCUMENTS

### Guidelines For Appropriation Applications

Application

Proposal Narrative (See application outline on page 3)

Attachment A

Attachment B

Attachment C

Copy of current IRS 501(c)(3) tax exempt statement indicating that you are not a private foundation and an explanation of any changes in your IRS status (if applicable)

Affidavit

Copy of Certificate of Good Standing with State of Louisiana

**ORDINANCE NO. 6193 OF 2022**

BY THE CADDO PARISH COMMISSION:

**AN ORDINANCE CREATING THE I-49 NORTH CORRIDOR ECONOMIC DEVELOPMENT DISTRICT, STATE OF LOUISIANA;" DEFINING THE BOUNDARIES THEREOF FROM WHICH AREA LOCAL SALES TAX, PROPERTY TAX AND HOTEL OCCUPANCY TAX INCREMENTS WILL BE DETERMINED AND USED TO FINANCE ECONOMIC DEVELOPMENT PROJECTS IN ACCORDANCE WITH AND AS AUTHORIZED BY PART II OF CHAPTER 27 OF TITLE 33 OF THE LOUISIANA REVISED STATUTES OF 1950, AS AMENDED; AND PROVIDING FOR OTHER MATTERS IN CONNECTION WITH THE FOREGOING.**

**WHEREAS**, Part II, Chapter 27, Title 33 of the Louisiana Revised Statutes of 1950, as amended (La. R S. 33:9038.31, *et seq.*) (the "EDD Act") authorizes municipalities, parishes and certain other local governmental subdivisions to create economic development districts to carry out the purposes of the Act, which economic development districts are political subdivisions of the State of Louisiana and possess such power and authority and have such duties as provided by the Act and other law; and

**WHEREAS**, La. R S. 33:9038.39 further permits such economic development districts tolevy sales and use taxes and hotel occupancy taxes at a rate up to two percent (2%) for authorized purposes subsequent to the creation and establishment of the District; and

**WHEREAS**, La. R S. 33:9038.34(O) provides that this governing authority may create a special trust fund for the furtherance of economic development projects, as defined in the EDD Act, into which the incremental increases in such sales taxes, property taxes and hotel occupancy taxes shall be deposited and loaned, granted, donated, or pledged in furtherance of economic development projects as defined in the EDD Act; and

**WHEREAS**, the Parish of Caddo, State of Louisiana (the "Parish"), acting through this Parish Commission as its governing authority, desires to avail itself of the EDD Act to create an economic development district to be called The "I-49 North Corridor Economic Development District, State of Louisiana" (the "District"), in accordance with La. R S. 33:9038.32, from which District local and State sales tax increments and local property and hotel occupancy tax increments are expected to be determined and used to fund the Parish of Caddo Economic Development District Trust Fund; and

**WHEREAS**, in accordance with the Act, particularly La. R S. 33:9038.32(8) and La. R S. 33:9038.39, and Resolution No. ? adopted on ?, 2021, the Parish has given notice of its intention to create the District, and notice that it will hold a public hearing relative to the proposed creation of the District, including a description of the boundaries of the District and containing a map showing the boundaries of the District, which notice has been published two times in the Parish's official journal; and

**WHEREAS**, on this date, prior to the adoption of this ordinance, this governing authority did hold a public hearing pursuant to the aforesaid notice of intention, at which public hearing no objections were received with respect to the creation of the District.

**NOW, THEREFORE, THE COMMISSION FOR THE PARISH OF CADDO HEREBY ORDAINS:**

SECTION 1. All of the above "Whereas" clauses are adopted as a part of this ordinance.

SECTION 2. Creation of District. Under the authority of La. R S. 33:9038.32 there is hereby created an economic development district within the Parish, to be named the "I-49 North Corridor Economic Development District, State of Louisiana," having the geographical boundaries set forth in Exhibit A attached hereto, which Exhibit A is hereby incorporated in and made a part of this Ordinance, all pursuant to the EDD Act. As provided by the EDD Act, the governing body of the District shall be this Parish Commission. As provided by the EDD Act, the District shall be a political subdivision of the State of Louisiana and shall possess such powers and authority and have such duties as provided in the EDD Act and other law.

SECTION 3. Creation of Trust Fund. Under the authority of La. RS. 33:9038.34(O), there is hereby created a special trust fund, to be named the "Parish of Caddo Economic Development District Trust Fund" (the "Trust Fund") the purpose of which will be to fund economic development projects selected by the District in the manner provided by the EDD Act. The Trust Fund shall be established by the Director of Finance of the Parish and maintained as a separate fund, apart from other funds and accounts of the Parish or other entities, and shall be used strictly for the purposes set forth herein and in the EDD Act.

SECTION 4. Authorization of Officers. The Parish Administrator is hereby authorized, empowered and directed to do any and all things necessary and incidental to carry out the provisions of this ordinance.

SECTION 5. Severability. If any provision of this ordinance shall be held to be illegal or invalid, such illegality or invalidity shall not affect any other provision of this ordinance, but this ordinance shall be construed and enforced as if such illegal or invalid provisions had not been contained herein. Any constitutional or statutory provision enacted after the date of this ordinance which validates or makes legal any provision of this ordinance which would not otherwise be valid or legal, shall be deemed to apply to this ordinance.

**BE IT FURTHER ORDAINED**, that this ordinance, shall become effective ten (10) days after publication.

**BE IT FURTHER ORDAINED**, that all ordinances or parts thereof in conflict herewith are hereby repealed.

Approved as to legal form:

---

Parish Attorney

## **EXHIBIT A to Creation Ordinance**

**BOUNDARIES AND MAP OF PROPOSED I-49 NORTH CORRIDOR  
ECONOMIC DEVELOPMENT DISTRICT, STATE OF LOUISIANA  
A CERTAIN TRACT OR PARCEL OF LAND SITUATED IN CADDO, PARISH,  
LOUISIANA AND BEING MORE PARTICULARLY DESCRIBED AS  
FOLLOWS:**

7.498 acres to be defined as from: That part of the Southeast Quarter (SE1/4) of Section Thirteen (13), Township Twenty-two (22) North, Range Fifteen (15) West, lying South of the North right of way line of the Hosston-Miller's Bluff Road and East of the West Bank of Kelly Bayou Canal and all of the South Half of the Southwest Quarter (S1/2 of SW1/4) of Section Thirteen (13), Township Twenty-two (22) North, Range Fifteen (15) West, lying East of the West bank of Kelly Bayou Canal

**ORDINANCE AND RESOLUTION FACT SHEET**

**CADDO PARISH COMMISSION**

<b>TITLE</b>	
Ordinance No. <u>6193</u> of 2022	
AN ORDINANCE CREATING THE I-49 NORTH CORRIDOR ECONOMIC DEVELOPMENT DISTRICT, STATE OF LOUISIANA;" DEFINING THE BOUNDARIES THEREOF FROM WHICH AREA LOCAL SALES TAX, PROPERTY TAX AND HOTEL OCCUPANCY TAX INCREMENTS WILL BE DETERMINED AND USED TO FINANCE ECONOMIC DEVELOPMENT PROJECTS IN ACCORDANCE WITH AND AS AUTHORIZED BY PART II OF CHAPTER 27 OF TITLE 33 OF THE LOUISIANA REVISED STATUTES OF 1950, AS AMENDED; AND PROVIDING FOR OTHER MATTERS IN CONNECTION WITH THE FOREGOING	
DATE: 1/28/2022	ORIGINATING DEPARTMENT: Legal for Commissioner Hopkins
<b>BACKGROUND INFORMATION</b>	
Commissioner Hopkins has requested an ordinance be prepared with boundaries that conform to the boundaries in the notice of intent resolution appearing on the January 31 <sup>st</sup> work session agenda. This property is a truck stop and travel center for which the IDB is also doing a PILOT lease. The TIF District boundaries will only cover the truck stop and travel center property.	
<b>FINANCIAL IMPACT AND SOURCE OF FUNDING</b>	
None	
<b>EFFECT(S) OF PROPOSED ACTION</b>	
Passage of the ordinance will result in the creation of the TIF District; failure to pass it will result in the TIF District not being created.	
<b>ALTERNATIVES/STAFF RECOMMENDATION</b>	
Staff has no recommendation.	
<b>KEY STAFF CONTACT</b>	
Donna Frazier, Parish Attorney	
<b>COORDINATION</b>	
Department Head	(Initial) <i>DF</i>
Parish Administrator/CEO	(Initial) <i>DF</i>